



ARIB TR—T16

**ENGLISH TRANSLATION**

**DEDICATED SHORT-RANGE  
COMMUNICATION SYSTEM**

**TEST ITEMS AND CONDITIONS FOR  
MOBILE STATION  
COMPATIBILITY CONFIRMATION**

**ARIB TECHNICAL REPORT**

VERSION 1.0

ARIB TR—T16

Version 1.0    September    9th    2001

Association of Radio Industries and Businesses (ARIB)

## General Notes to the English translation of ARIB Standards and Technical Reports

1. The copyright of this document is ascribed to the Association of Radio Industries and Businesses (ARIB).
2. All rights reserved. No part of this document may be reproduced, stored in a retrieval system, or transmitted, in any form or by any means, without the prior written permission of ARIB.
3. The ARIB Standards and ARIB Technical Reports are usually written in Japanese and approved by the ARIB Standard Assembly. This document is a translation into English of the approved document for the purpose of convenience of users. If there are any discrepancies in the content, expressions, etc., between the Japanese original and this translated document, the Japanese original shall prevail.
4. The establishment, revision and abolishment of ARIB Standards and Technical Reports are approved at the ARIB Standard Assembly, which meets several times a year. Approved ARIB Standards and Technical Reports, in their original language, are made publicly available in hard copy, CDs or through web posting, generally in about one month after the date of approval. The original document of this translation may have been further revised and therefore users are encouraged to check the latest version at an appropriate page under the following URL:

<http://www.arib.or.jp/english/index.html>

## Foreword

The Association of Radio Industries and Businesses (ARIB) has been investigating and summarizing the basic technical requirements for establishing standards and technical reports with the participation of the various radio equipment manufacturers, telecommunications companies, broadcasters, and users.

This technical report contained herein will serve as private-sector guideline for the measurement methods and testing methods, etc., in order to ensure the quality and compatibility of radio facilities and equipment for private use based on the publicly established technical standards and private-sector voluntary standards in Japan.

These technical reports are being established principally for “the test items and conditions for land mobile station compatibility confirmation for the Dedicated Short-Range Communication System”. In order to ensure fairness and openness among all parties involved, during drafting stages, we invite radio equipment manufacturers, operators, testing organizations and users both domestically and overseas to participate openly in the activities of the Standard Assembly so as to develop technical reports with the total agreement of all parties involved.

The scope of application of these technical reports covers the minimum requirements for the fundamental items assured compatibility for the mobile stations with the base stations based on Dedicated Short-Range Communication System. On the application of this technical report, the test organizations related to operators and radio equipment manufacturers, etc., should use them together with practical guidelines for operators in developing original specifications and systems that fall within the scope of the standards.

We hope that this technical report will aid all parties involved, including radio equipment manufacturers, operators, users, testing organizations and others.



## Contents

Foreword	
Chapter 1 General Terms	1
1.1 Overview	1
1.2 Test Classification	1
Chapter 2 Test by Test Equipment (DSRC conformance confirmation test)	2
2.1 Scope	2
2.2 Test Configuration	2
2.3 Test Items and Test Conditions	4
2.3.1 Test Items	4
2.3.1.1 Technical requirements for radio facilities and equipments	4
2.3.1.1.1 ASK	4
2.3.1.1.2 $\pi/4$ shift QPSK	4
2.3.1.2 Communication protocol	5
2.3.2 Basic parameters	8
2.3.2.1 Layer 1 parameters	8
2.3.2.2 Layer 2 parameters	8
2.3.2.3 Layer 7 parameters	9
2.3.2.4 Test application parameters	9
2.3.2.5 Parameters notified by a DUT (OBE manufacturer)	9
2.3.2.6 Test sequence	10
2.3.3 Test method and procedures	17
2.3.3.1 Technical requirements for radio facilities and equipments	17
2.3.3.1.1 ASK	17
2.3.3.1.2 $\pi/4$ shift QPSK	18
2.3.3.2 Communication protocol	20
2.3.3.2.1 Basic operation test	20
2.3.3.2.2 Propagation simulation field operation test	50
Chapter 3 Application Interface Conformance Confirmation Test	59
3.1 Scope	59
3.2 Test configuration	59
3.3 Out line of the application interface conformance confirmation test	60

3.3.1 ETC interface conformance confirmation test for the ETC OBE .....	60
3.3.2 Application interface conformance confirmation test for the non-ETC OBE ..	60
3.4 Test items and Test conditions .....	60
3.4.1 ETC OBE .....	60
3.4.1.1 Tests for ETC application functions .....	60
3.4.1.2 Tests for the external interface function .....	60
3.4.1.3 Tests for other functions .....	61
3.4.2 non-ETC OBE .....	61
3.4.2.1 Tests for the external interface function .....	61
3.4.2.2 Tests for other functions, else the external interface function .....	61
3.5 Tests for the external interface function .....	61
3.5.1 Test items and procedures .....	61
Annex 1 Basic Concept Regarding the DSRC Test Procedure .....	A1-1
Annex 2 Test Program Specifications for OBE .....	A2-1
Annex 3 Relationship between the function classification of OBEs and test items by the test equipment .....	A3-1
Annex 4 List of Test Items Using Test Equipment .....	A4-1
Annex5 Compatibility conformance confirmation test between ARIB STD-T55 and ARIB STD-T75 for ETC .....	A5-1

## Chapter 1 General Terms

### 1.1 Overview

The testing regarding the compatibility of the Dedicated Short-Range Communication (DSRC) System land mobile stations (hereafter "mobile stations or On Board Equipment (OBE)") is positioned as the suitability check for the radio interface specified in the DSRC System Standards (ARIB STD-T75) and is carried out for each type within the scope of basic functions and standardized options defined in that standard. The type indicated herein is equal to the same type in principle, which is used for the tests related to the Technical Standards Conformance Certification conducted by Telecom Engineering Center Foundation or includes it.

It is the assumption before the testing that the conduct of equipment according to the above standard is fully confirmed with the responsibility of the mobile station manufacturer during the development or manufacturing process.

The testing can be performed in a general testing environment and no special burden will be placed on the testing organization or manufacturer to establish a testing environment or to add functions to the mobile stations.

### 1.2 Test Classification

The testing for compatibility confirmation is divided into testing using Test Equipment and application interface compatibility confirmation test, and the main party that will perform the testing is the mobile station manufacturer.

Test Equipment based on the test items and Test conditions about it conducts the testing using Test Equipment.

The application interface compatibility confirmation test is conducted by connecting the mobile station that has been completed the test by Test Equipment with the test system, and is conducted based on the test items and test conditions of it.

The order between the above tests and the test for Technical Standards Conformity Certification does not need to be considered.

## Chapter 2 Test by Test Equipment (DSRC conformance confirmation test)

### 2.1 Scope

The testing using Test Equipment is that the mobile station manufacturer confirms that the manufactured mobile stations (OBEs) satisfy the specifications of mobile station for the DSRC System Standards (ARIB STD-T75) by using Test Equipment.

### 2.2 Test Configuration

An example configuration for the testing using Test Equipment is shown in Fig. 2.1.

Test Equipment is generally called a base station simulator and contains RF transmission and reception characteristic functions and the basic functions for transmitting and receiving signals to and from the mobile station. But in this technical report the detailed type of this equipment is not specified and is defined as any device that can perform the functions.

Test Equipment contains Test program for conducting test of DUT (Device Under Test: OBE) installed with the OBE Test Program given in Annex 2.

The connection method between Test Equipment and DUT (OBE) under test is considered the following two methods.

- (1) The case of connecting by RF coupling or connector in a shield room or a shield box.

The example test configuration of Test Equipment of this case is shown in Fig.2.1-1.

- (2) The case of freely connecting by RF signal. Because both DUT (OBE) under test and Test Equipment are given the Technical Standards Conformity Certification as the mobile station of DSRC system and the radio station to communicate to the DUT (OBE) for testing a RF section. And Article 4-3 of Radio Law and Article 6-4-7 of the Radio Facility Regulation in Japan defines such radio stations. The example test configuration of Test Equipment of this case is shown in Fig.2.1-2.

But Annex Q of the DSRC system standards ARIB STD-T75 must be kept strictly for the installation and operation of Test Equipment and mobile station under test. And it is necessary to consider giving no interference and no disturbance to other communications.

The above two methods may be used properly according to the item of testing

Hereafter in this document, mobile station will be expressed as OBE (On-Board Equipment) and Test Equipment as TE (Test Equipment).

Shield room or shield box

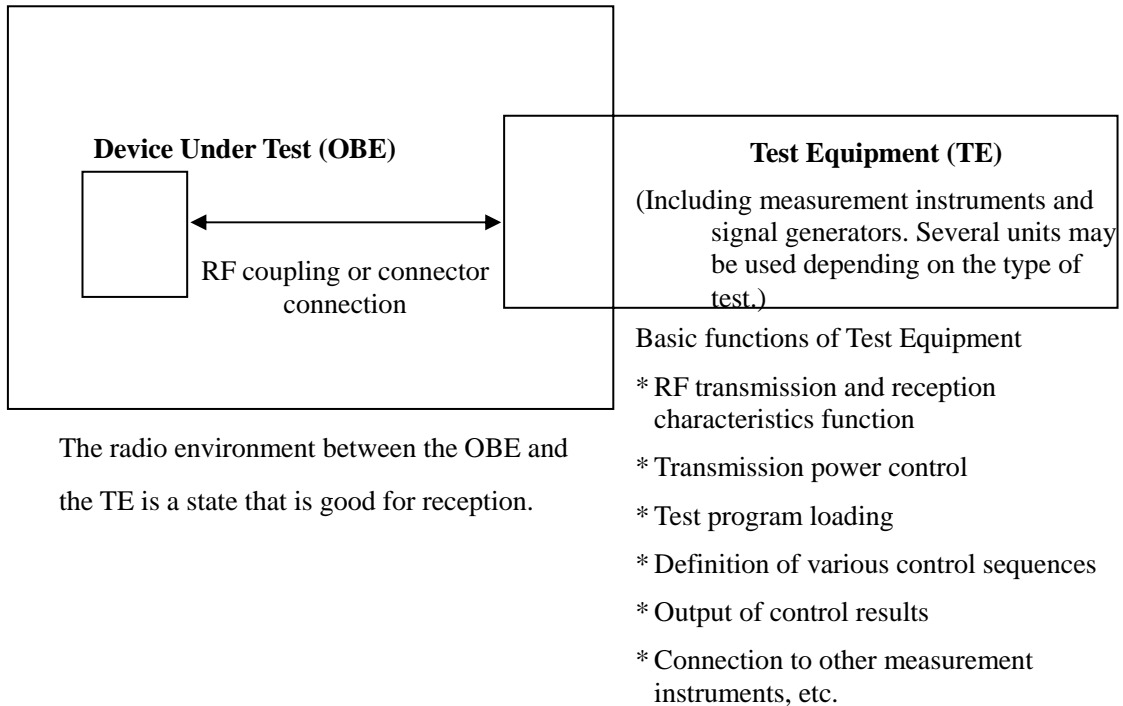
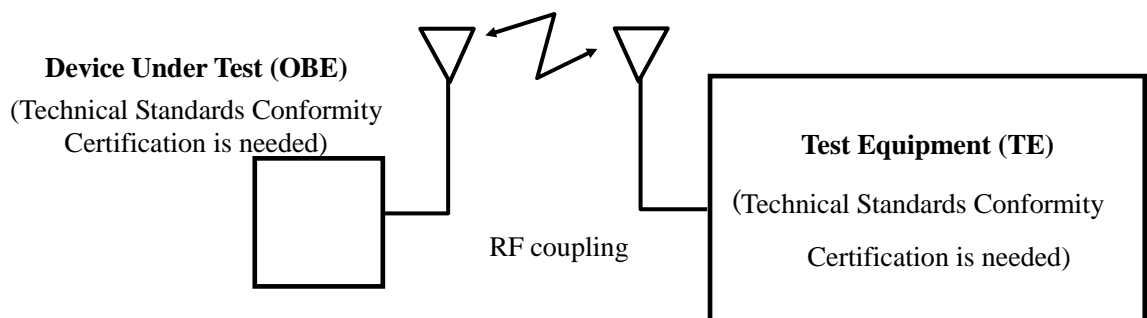

Fig. 2.1-1 Example configuration 1 for testing using Test Equipment



It is necessary to consider giving no interference and no disturbance to other communications.

Fig. 2.1-2 Example configuration 2 for testing using Test Equipment

## 2.3 Test Items and Test Conditions

### 2.3.1 Test Items

#### 2.3.1.1 Technical requirements for radio facilities and equipments

Test items for the technical requirements for radio facilities and equipments using Test Equipment are as following defined in 2.3.1.1.1 for ASK and 2.3.1.1.2 for  $\pi/4$  shift QPSK defined by ARIB STD-T75. (Depending on notification of communication profiles from a device under test (DUT (OBE)), it will be determined which modulation method, ASK or  $\pi/4$  shift QPSK, is adopted.)

##### 2.3.1.1.1 ASK

<u>test numbers</u>	<u>test items</u>
1-1-A	transmitter
1-1-1-A	frequency stability
1-1-2-A	occupied frequency bandwidth
1-1-3-A	transmission spurious
1-1-4-A	transmission power accuracy
1-1-5-A	adjacent channel leakage power
1-1-6-A	leakage power during carrier of period
1-1-7-A	transmission symbol rate accuracy
1-1-8-A	allowable deviation of absolute signal transmission time burst transmission transient response time
1-2-A	receiver
1-2-1-A	reception sensitivity
1-2-2-A	strength of secondary radio emissions

##### 2.3.1.1.2 $\pi/4$ shift QPSK

<u>test numbers</u>	<u>test items</u>
1-1-Q	transmitter
1-1-1-Q	frequency stability
1-1-2-Q	occupied frequency bandwidth
1-1-3-Q	transmission spurious
1-1-4-Q	transmission power accuracy

1-1-5-Q	adjacent channel leakage power
1-1-6-Q	leakage power during carrier of period
1-1-7-Q	transmission symbol rate accuracy
1-1-8-Q	allowable deviation of absolute signal transmission time burst transmission transient response time
1-2- Q	receiver
1-2-1-Q	reception sensitivity
1-2-2-Q	strength of secondary radio emissions

### 2.3.1.2 Communication protocol

The test items for the test communication protocol using Test Equipment are as follows.

This test is conducted on mobile station basic sessions (Refer to "Annex 1 Basic Concepts Regarding the DSRC Test Procedure."), and a test program (Refer to "Annex 2 Test Program Specifications for OBE.") Depending on notification of communication profiles from DUT (OBE), it will be determined which modulation method, ASK or  $\pi/4$  shift QPSK, is adopted in the test.

<u>test numbers</u>	<u>test items</u>
2-1	basic operation test
2-1-1	ACTC transmissions in normal condition
2-1-2	ACTC transmission constraints – in case of reaching maximum transmission retry number
2-1-3	ACTC transmission constraints – in case of unable indication in an ACPI
2-1-4	ACTC transmission constraints – in case of reception of an FCMC registered corresponding LID
2-1-5	ACTC transmissions – in case of reception of an FCMC registered AIDs
2-1-6	BST reception
2-1-7	VST transmission
2-1-8	Initialization using communication profile(s)
2-1-9	Termination Procedures 1
2-1-10	Termination Procedures 2
2-1-11	Transaction test using one PDU
2-1-12	Transaction test using plural PDUs
2-1-13	Transaction test – duplication check of PDU

## ARIB TR-T16

- 2-1-14 Transaction test – OBE retransmission
  - 2-1-15 Transaction test – OBE retransmission request
  - 2-1-16 WCNC transmission
  - 2-1-17 ACTC transmission control by STA in FCMC (Note)
  - 2-1-18 Transaction test – fragmentation and de-fragmentation of PDU (Note)
  - 2-1-19 Termination Procedures 3 (Note)
  - 2-1-20 Re-initialization in case of reception of release (Note)
  - 2-1-21 Reception of PDU addressed multicast (group) address
  - 2-1-22 Reception of PDU addressed broadcast address
- 2-2 Propagation simulation field operation test
- 2-2-1 Normal speed propagation simulation field operation test
    - 2-2-1-1 Normal speed propagation simulation field operation test – ideal profile – maximum input power at an OBE
    - 2-2-1-2 Normal speed propagation simulation field operation test – ideal profile – minimum input power at an OBE
    - 2-2-1-3 Normal speed propagation simulation field operation test – practical profile A
    - 2-2-1-4 Normal speed propagation simulation field operation test – practical profile B
    - 2-2-1-5 Normal speed propagation simulation field operation test –adjacent lane passing profile
    - 2-2-1-6 Normal speed propagation simulation field operation test –shadowing profile
  - 2-2-2 Low speed simulation field test
    - 2-2-2-1 Low speed propagation simulation field operation test – ideal profile – maximum input power at an OBE
    - 2-2-2-2 Low speed propagation simulation field operation test – ideal profile – minimum input power at an OBE
    - 2-2-2-3 Low speed propagation simulation field operation test – practical profile A
    - 2-2-2-4 Low speed propagation simulation field operation test – practical profile B

- 2-2-2-5 Low speed propagation simulation field operation test –adjacent lane passing profile
- 2-2-2-6 Low speed propagation simulation field operation test –shadowing profile
  
- 2-2-3 High speed simulation field test
  - 2-2-3-1 High speed propagation simulation field operation test – ideal profile – maximum input power at an OBE
  - 2-2-3-2 High speed propagation simulation field operation test – ideal profile – minimum input power at an OBE
  - 2-2-3-3 High speed propagation simulation field operation test – practical profile A
  - 2-2-3-4 High speed propagation simulation field operation test – practical profile B
  - 2-2-3-5 High speed propagation simulation field operation test – adjacent lane passing profile
  - 2-2-3-6 High speed propagation simulation field operation test – shadowing profile

(Note) These test items are functions specified in an application function unit. Refer to Annex 3: Relationship between the function categories of an OBE and test items by the test equipment.

## ARIB TR-T16

### 2.3.2 Basic parameters

The parameters that are set and registered during testing are as follows. These parameters apply unless otherwise specified.

The meaning of the notes in Items 2.3.2.1 and 2.3.2.4 (TE), (OBE), (Common) are as follows.

TE: This is a parameter that is registered in FCMC by TE.

OBE: This is a parameter that is set or registered in OBE.

Common: This is a parameter that is set or registered in both TE and OBE.

#### 2.3.2.1 Layer 1 parameters

The DUT (OBE) notifies which is ASK or  $\pi/4$  shift QPSK defined by ARIB STD-T75 by communication profile(s).

#### 2.3.2.2 Layer 2 parameters

\*Frame class: B (TE)

(Note: The frame class definition is as per ARIB STD-T75 Item 4.2.9.)

\*Communication mode: Half duplex communication (TE)

\*Communication zone: Stand alone (TE)

\*Transmitter/receiver identifier TRI: Not set (TE)

\*Time division: None (TE)

\*Communication area: Class 1 (TE)

\*LLC: type 1 procedure only (common)

\*Link request status identifier ACPI: Authorized. (TE)

\*The multiple information STA is "100 to 50%." (TE)

\*Release time: 2 seconds fixed, valid identifier: Always valid. (TE)

\*NRQmax: 127 (OBE)

\*Link request limit frequency: RT1 = 1, RT2 = 2, RT3 = 4, RT4 = 4. (OBE)

\*For information regarding the SC in FCMC and the LRI in ACTC, refer to Chapter 4 in

"Annex 2 Test Program Specifications for OBE." (Common)

\*Priority allocation is not conducted. (Common)

### 2.3.2.3 Layer 7 parameters

- \* Concatenation: None (Common)
- \* Connection procedure: Standard initialization mode (TE)
- \* EID: Elective number from 4 to 127 (OBE)
- \* FID: 1 (TE)
- \* PDU header's PDU No.: Elective number from 2 to 15 (Common)
- \*EID for the testing of group/all multicast: 127

### 2.3.2.4 Test application parameters

For information regarding the Attribute TestData group (TestData1 for the case that the communication profile is 9 or 10. Attribute is defined fortunately for other communication profiles) using in the test, refer to "Annex 2 Test Program Specifications for OBE."(OBE)

### 2.3.2.5 Parameters notified by a DUT (OBE manufacturer)

The parameters notified in advance by the manufacturer during testing are as follows.

- \* Frequency mode: Either A mode or B mode is specified. (TE)
- \* Scramble validation (Common)
- \* Frame formats (TE)

The frame format is that only the slot 3 is selected MDS or WCNS as shown below.

The others are fixed.

FCMS + MDS (normally vacant) + MDS (normally vacant) + MDS/WCNS + ACTS

ACTC is ACTC (1) to ACTC (6).

Or the frame formats by standard slot assignment procedure is selected.

- \* AID: one from among 0,14,17,18 is selected
- \* Connection timer: the value to be indicated is used
- \* Communication profile: one from among 9,10 (11,12:for further extension) is selected
- \* Address of group multicast: one from among 121 to 126 is selected

#### 2.3.2.6 Test sequence

The sequence used for dynamic operation testing is as follows. This sequence is written mainly in the Testing Equipment.

- [1] ACTC reception
- [2] BST transmission
- [3] VST reception
- [4] Writes the data that is randomly generated in the TestData1 Attribute by the set primitive.
- [5] Reads the data from the TestData 1 Attribute from the get primitive. Data inquiry is conducted.
- [6] Transmits a release.
- [7] Conducts WCNS allocation.

2.3.2.7 Propagation Profile

The propagation profile used during the propagation simulation field operation is as follows.

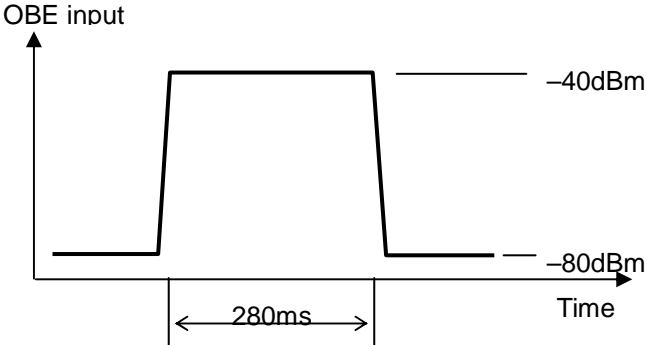
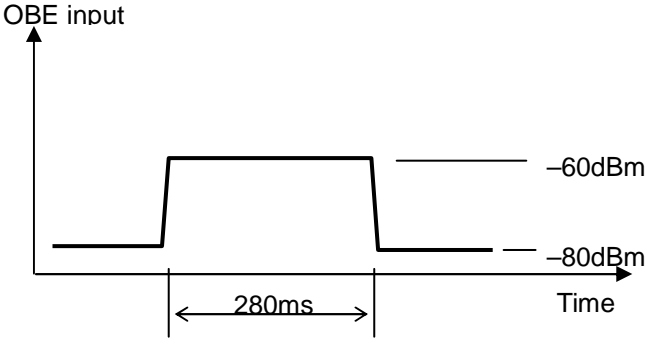
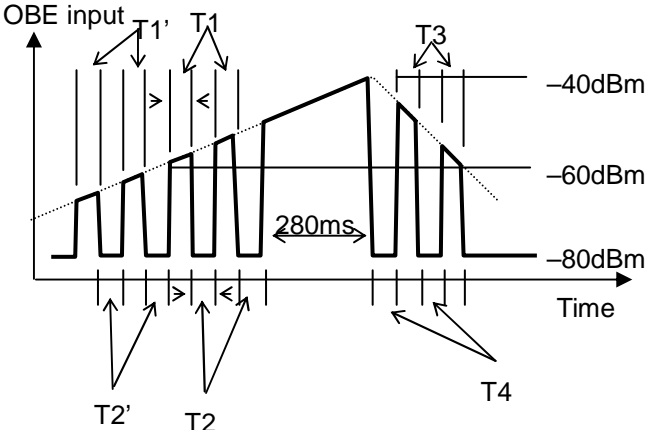
Test number	Test Items	Propagation Profile
1-1	Normal speed Propagation simulation field operation test – ideal profile – maximum input power at an OBE	 <p>OBE input</p> <p>Time</p> <p>280ms</p> <p>-40dBm</p> <p>-80dBm</p>
1-2	Normal speed Propagation simulation field operation test – ideal profile – minimum input power at an OBE	 <p>OBE input</p> <p>Time</p> <p>280ms</p> <p>-60dBm</p> <p>-80dBm</p>
2-1	Normal speed Propagation simulation field operation test – practical profile A	 <p>OBE input</p> <p>Time</p> <p>280ms</p> <p>-40dBm</p> <p>-60dBm</p> <p>-80dBm</p> <p>T1, T1', T2, T2', T3, T4</p> <p>The T1, T2, T3, T4, T1', and T2' relationship is the number of peaks n1 made by T1 and the number of peaks n2 made by T3 such that:  <math>T1' = T1 = T3 = 3ms, T2' = T2 = T4 = 3ms</math>  <math>n1 = 4, n2 = 2</math></p>

ARIB TR-T16

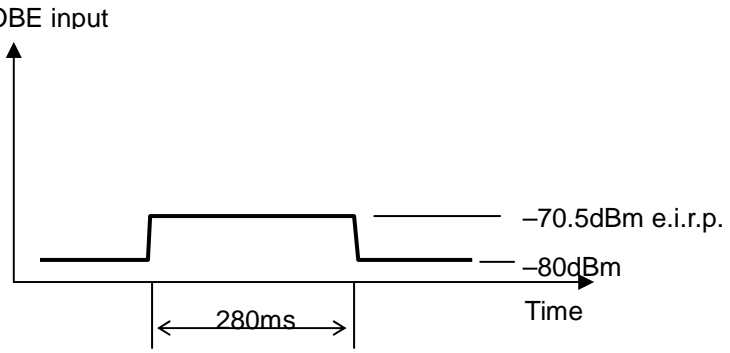
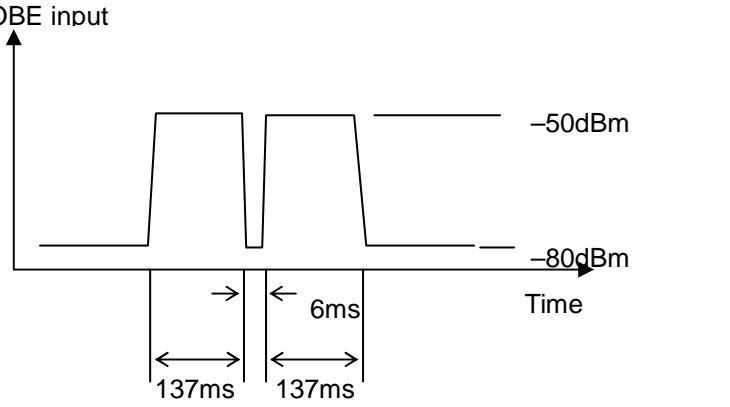
Test number	Test Items	Propagation Profile
2-2	Normal speed Propagation simulation field operation test –practical profile B	When there are two OBE units for the same radio bandwidth as in the 2-1 pattern.
3	Normal speed Propagation simulation field operation test –adjacent lane passing profile	<p>OBE input</p>  <p>–70.5dBm e.i.r.p. –80dBm Time 280ms</p>
4	Normal speed Propagation simulation field operation test – Shadowing profile	<p>OBE input</p>  <p>–50dBm –80dBm Time 137ms 6ms 137ms</p>

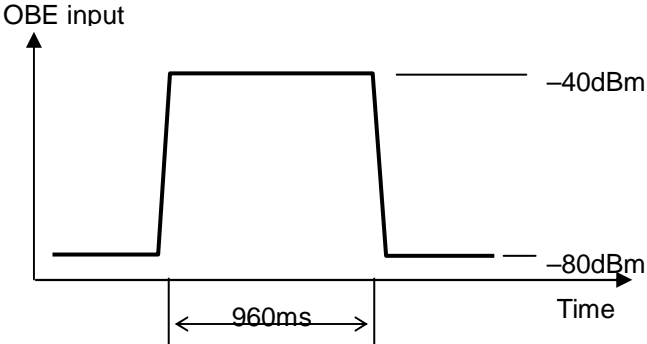
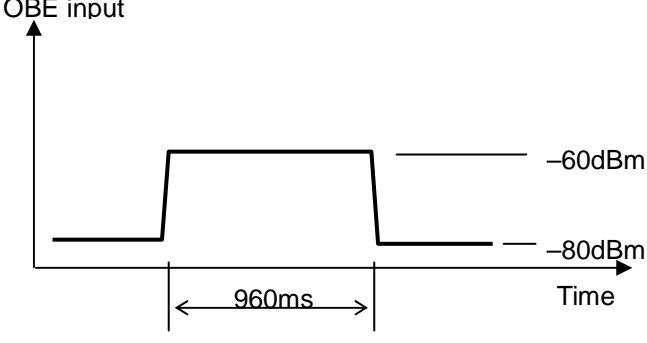
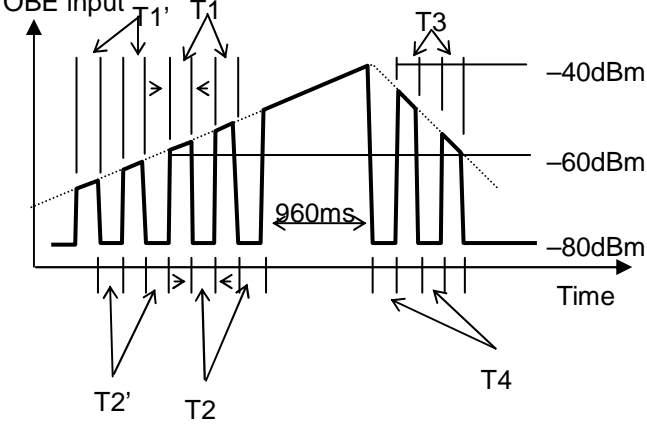
Test number	Test Items	Propagation Profile
5-1	Low speed Propagation simulation field operation test – ideal profile – maximum input power at an OBE	 <p>OBE input</p> <p>Time</p> <p>960ms</p> <p>-40dBm</p> <p>-80dBm</p>
5-2	Low speed Propagation simulation field operation test – ideal profile – minimum input power at an OBE	 <p>OBE input</p> <p>Time</p> <p>960ms</p> <p>-60dBm</p> <p>-80dBm</p>
6-1	Low speed Propagation simulation field operation test – Practical profile A	 <p>OBE input</p> <p>Time</p> <p>960ms</p> <p>-40dBm</p> <p>-60dBm</p> <p>-80dBm</p> <p>T1', T1, T3, T2', T2, T4</p> <p>The T1, T2, T3, T4, T1', and T2' relationship is the number of peaks n1 made by T1 and the number of peaks n2 made by T3 such that:                      T1' = T1 = T3 = 3ms, T2' = T2 = T4 = 3ms                      n1 = 4, n2 = 2</p>

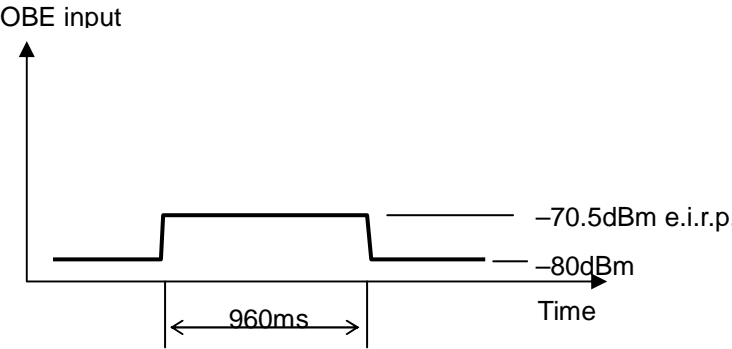
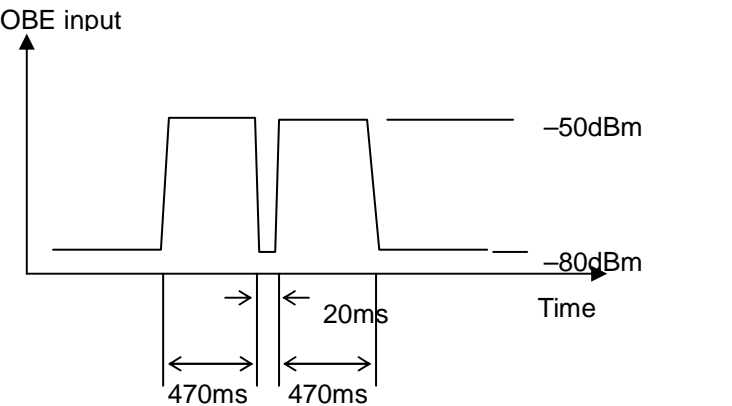
Test number	Test Items	Propagation Profile
6-2	Low speed Propagation simulation field operation test -practical profile B	When there are two OBE units for the same radio bandwidth as in the 6-1 pattern.
7	Low speed Propagation simulation field operation test -Adjacent lane passing profile	<p>OBE input</p>  <p>Time</p>
8	Low speed Propagation simulation field operation test -shadowing profile	<p>OBE input</p>  <p>Time</p>

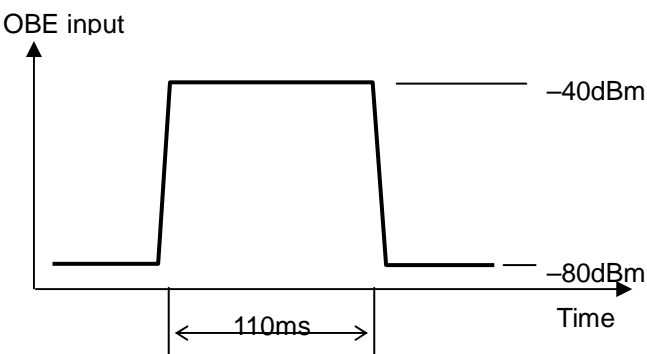
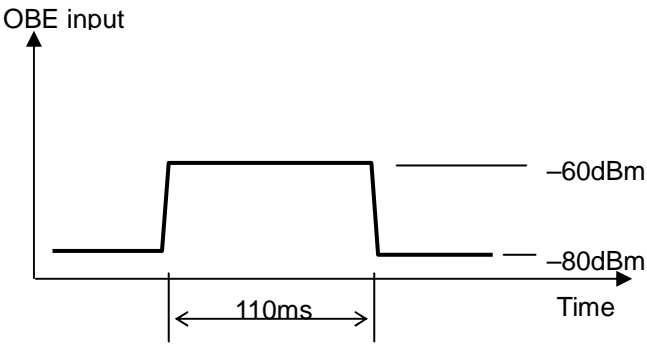
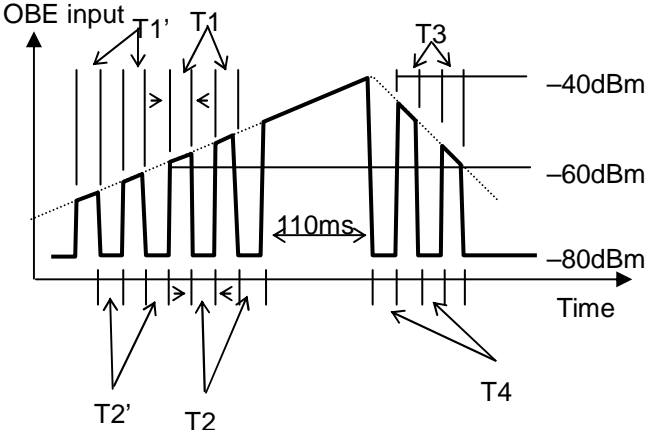
Test number	Test Items	Propagation Profile
9-1	High speed Propagation simulation field operation test – Ideal profile – maximum input power at an OBE	 <p>OBE input</p> <p>Time</p> <p>110ms</p> <p>-40dBm</p> <p>-80dBm</p>
9-2	High-speed running test Ideal pattern OBE min. input	 <p>OBE input</p> <p>Time</p> <p>110ms</p> <p>-60dBm</p> <p>-80dBm</p>
10-1	High speed Propagation simulation field operation test –practical profile A	 <p>OBE input</p> <p>Time</p> <p>110ms</p> <p>-40dBm</p> <p>-60dBm</p> <p>-80dBm</p> <p>T1', T1, T3, T2', T2, T4</p> <p>The T1, T2, T3, T4, T1', and T2' relationship is the number of peaks n1 made by T1 and the number of peaks n2 made by T3 such that:                      T1' = T1 = T3 = 3ms, T2' = T2 = T4 = 3ms                      n1 = 4, n2 = 2</p>

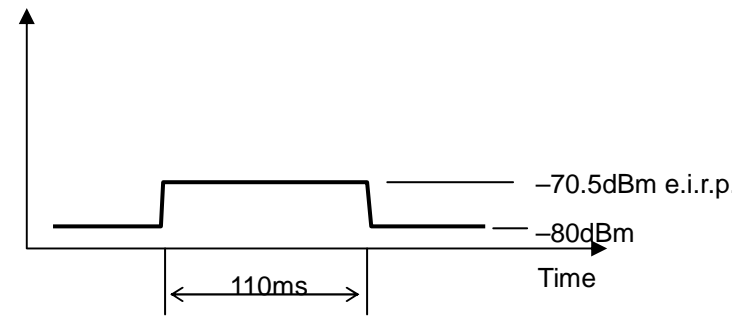
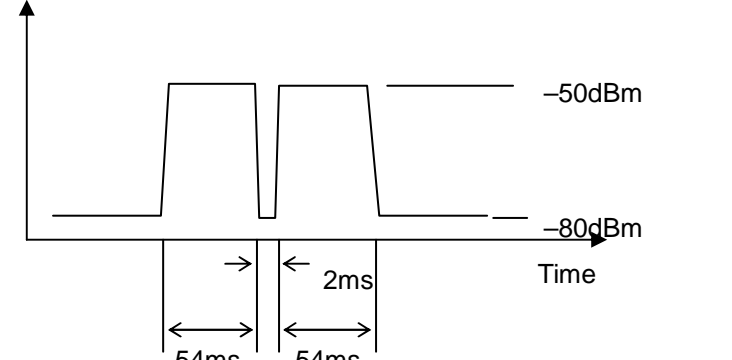
Test number	Test Items	Propagation Profile
10-2	High speed Propagation simulation field operation test – practical profile B	When there are two OBE units for the same radio bandwidth as in the 10-1 pattern.
11	High speed Propagation simulation field operation test –adjacent lane passing profile	<p>OBE input</p>  <p>Time</p>
12	High speed Propagation simulation field operation test –shadowing profile	<p>OBE input</p>  <p>Time</p>

### 2.3.3 Test method and procedures

#### 2.3.3.1 Technical requirements for radio facilities and equipments

Test items for the technical requirements for radio facilities and equipments are shown in figure 2.1 and 2.2 (ASK method specified in ARIB STD-T75) and figure 2.3 and 2.4 ( $\pi/4$  shift QPSK). Test method and procedures should be conformed to ARIB STD-T75 chapter 5, measurement method. (Depending on notification of communication profiles from a DUT (OBE), it will be determined which modulation method, ASK or  $\pi/4$  shift QPSK, is adopted.)

##### 2.3.3.1.1 ASK

Table 2.1 ASK transmitter test

Test number	Test items	Specification
1-1-1-A	frequency stability	$< \pm 50 \times 10^{-6}$
1-1-2-A	occupied frequency bandwidth	$< 4.4\text{MHz}$
1-1-3-A	transmission spurious	$< 25\mu\text{W}$
1-1-4-A	transmission power accuracy	Transmission power: $< 10\text{mW}$ transmission power accuracy: $< \pm 50\%$
1-1-5-A	adjacent channel leakage power	@ $\pm 1$ channel: $< -30\text{dBc}$ @ $\pm 2$ channel: $< -40\text{dBc}$
1-1-6-A	leakage power during carrier of period	$< 2.5 \mu\text{W}$
1-1-7-A	transmission symbol rate accuracy	transmission symbol rate accuracy: $< \pm 100 \times 10^{-6}$ (signal transmission rate: $1024.000\text{kbps}$ )
1-1-8-A	Allowable deviation of absolute signal transmission time and burst transmission transient response time	$\Delta \text{Tabs} < 5\mu\text{s}$ , $\text{Tbst} < 5\mu\text{s}$ , Where, $\Delta \text{tabs}$ : Allowable deviation of absolute signal transmission time $\text{Tbst}$ : burst transmission transient response time

Table 2.2 ASK receiver test

Test number	Test items	Specification
1-2-1-A	reception sensitivity	Bit Error Rate: $<1 \times 10^{-5}$ @more than -60.5dBm e.i.r.p and less than -39.6dBm e.i.p. (bore sight direction)
1-2-2-A	strength of secondary radio emissions	$<2.5 \mu\text{W}$

2.3.3.1.2  $\pi/4$  shift QPSKTable 2.3  $\pi/4$  shift QPSK transmitter test

Test number	Test items	Specification
1-1-1-Q	frequency stability	$< \pm 50 \times 10^{-6}$
1-1-2-Q	occupied frequency bandwidth	$<4.4\text{MHz}$
1-1-3-Q	transmission spurious	$<25\mu\text{W}$
1-1-4-Q	transmission power accuracy	Transmission power: $<10\text{mW}$ Transmission power accuracy: $< \pm 50\%$
1-1-5-Q	adjacent channel leakage power	@ $\pm 1$ channel: $<-30\text{dBc}$ @ $\pm 2$ channel: $<-40\text{dBc}$
1-1-6-Q	leakage power during carrier of period	$<2.5 \mu\text{W}$
1-1-7-Q	transmission symbol rate accuracy	Transmission symbol rate accuracy: $< \pm 100 \times 10^{-6}$ (signal transmission rate: 4096.000kbps)
1-1-8-Q	Allowable deviation of absolute signal transmission time and burst transmission transient response time	$\Delta \text{tabs} < 5\mu\text{s}$ , $T_{\text{bst}} < 5\mu\text{s}$ , Where, $\Delta \text{tabs}$ : Allowable deviation of absolute signal transmission time $T_{\text{bst}}$ : burst transmission transient response time

Table 2.4  $\pi/4$  shift QPSK receiver test

Test number	Test items	Specification
1-2-1-Q	reception sensitivity	Bit Error Rate: $<1 \times 10^{-5}$ @more than -65dBm e.i.r.p and less than -44.1dBm e.r.i.p. (bore sight direction)
1-2-2-Q	strength of secondary radio emissions	$<2.5 \mu\text{W}$

## 2.3.3.2 Communication protocol

Test method and procedures for the communication protocol are as follows.

## 2.3.3.2.1 Basic operation test

Test number	2-1-1	Items	Basic operation ACTC transmission in normal condition
Test overview			
Verify that an OBE that normally the received FCMC could transmit an ACTC.			
Test conditions			
<ul style="list-style-type: none"> <li>Basic parameters shall be set as section 2.3.2</li> </ul>			
Test procedure			
<ol style="list-style-type: none"> <li>The TE (test equipment) transmits FCMCs.</li> <li>TE receives ACTC frame transmitted by the OBE.</li> <li>TE verifies whether ACTC in the ACTC transmission window (1) through (6) is conformed to standard.</li> <li>TE verifies whether ACTC in the ACTC transmission window (1) through (6) is conformed to standard by CRC check.</li> </ol>			
Confirmation items (Note)			
(1) ASK			
<ul style="list-style-type: none"> <li>Verify that each ACTC, in the ACTC transmission window from (1) through (6), received by the TE have UW2, FID and LRI conformed to standard.</li> <li>Verify that each ACTC, in the ACTC transmission window from (1) through (6), received by the TE is valid ACTC frame by CRC calculation check.</li> <li>Verify that the OBE could transmit ACTC in the ACTC transmission window randomly selected from (1) through (6).</li> <li>Verify that each ACTC, in the ACTC transmission window from (1) through (6), received by the TE has an LID field conformed to standard.</li> </ul>			
(2) $\pi/4$ shift QPSK			
<ul style="list-style-type: none"> <li>Verify that each ACTC, in the ACTC transmission window from (1) through (6), received by the TE have UW2A, FID and LRI conformed to standard.</li> <li>Verify that each ACTC, in the ACTC transmission window from (1) through (6), received by the TE is valid ACTC frame by CRC calculation check.</li> <li>Verify that the OBE could transmit ACTC in the ACTC transmission window randomly selected from (1) through (6).</li> <li>Verify that each ACTC received by the TE has an LID field conformed to standard.</li> </ul>			

(Note) Confirmation items depend on the notified communication profile(s) of DUT(OBE).

Test number	2-1-2	Items	Basic operation: ACTC transmission constraint – in case of reaching maximum transmission retry number
Test overview Verify that an OBE that could stop the ACTC transmission in case of reaching the maximum link request transmission number (NFR2max) on the OBE.			
Test conditions • Basic parameters shall be set as section 2.3.2			
Test procedure 1. Transmit FCMCs from the TE (test equipment). 2. The OBE transmits ACTC as response to the received FCMC from the TE. 3. The TE does not register corresponding LID of the received ACTC at the FCMC.			
Confirmation items • Verify that an OBE that could stop the ACTC transmission.			

Test number	2-1-3	Items	Basic operation ACTC transmission constraint – in case of unable indication in an ACPI
Test overview Verify that an OBE that could stop the ACTC transmission in case of receiving ACPI indicated unable initialization flag on the OBE.			
Test conditions • Basic parameters shall be set as section 2.3.2.			
Test procedure 1. Transmit FCMCs from the TE (test equipment). 2. The OBE transmits ACTC as response to the received FCMC from the TE. 3. The TE does not register corresponding LID of the received ACTC at the FCMC. 4. The TE transmits FCMC, which contains ACPI indicated unable initialization flag.			
Confirmation items • Verify that an OBE that could stop the ACTC transmission.			

Test number	2-1-4	Items	Basic operation ACTC transmission constraint – in case of reception of an FCMC registered corresponding LID
<p>Test overview</p> <p>Verify that an OBE that could stop the ACTC transmission in case of receiving FCMC indicated the same LID as the transmitted ACTC ones on the OBE.</p>			
<p>Test conditions</p> <ul style="list-style-type: none"> <li>• Basic parameters shall be set as section 2.3.2.</li> </ul>			
<p>Test procedure</p> <ol style="list-style-type: none"> <li>1. Transmit FCMCs from the TE (test equipment).</li> <li>2. The OBE transmits ACTC as response to the received FCMC from the TE.</li> <li>3. The TE receives ACTC and registers the corresponding LID at the received ACTC.</li> </ol>			
<p>Confirmation items</p> <ul style="list-style-type: none"> <li>• Verify that the OBE that could stop the ACTC transmission.</li> </ul>			

Test number	2-1-5-1	Items	Basic operation: ACTC transmission – in case of reception of an FCMC registered AID(s) (1)		
<b>Test overview</b>					
Verify that an OBE that can transmit the ACTC conformed to the specification, that the LRI field should be set the comparison results between own AIDs and AIDs in FCMC transmitted from TE.					
<b>Test conditions</b>					
<ul style="list-style-type: none"> <li>• Basic parameters shall be set as section 2.3.2.</li> <li>• 4 SC profiles test as illustrated below table shall be conducted. Each test SC profile shall contain AID (AID=0) to enable DUT (OBE) to response for it.</li> </ul>					
	FCMC.SC	AID (1)	AID (2)	AID (3)	AID (4)
	1st	XYH(AID=0)	FFH	FFH	FFH
	2nd	E8H (AID=29)	XYH(AID=0)	FFH	FFH
	3rd	E8H (AID=29)	F0H (AID=30)	XYH (AID=0)	FFH
	4th	E8H (AID=29)	F0H (AID=30)	E8H (AID=29)	XYH (AID=0)
<b>Test procedure</b>					
<ol style="list-style-type: none"> <li>1. The TE transmits FCMC, which contains SC fields as AID (1)=01H,AID (2)~AID (4)=FFH.</li> <li>2. The TE receives ACTC transmitted by DUT (OBE).</li> <li>3. The TE verifies that the received ACTC is valid.</li> <li>4. The TE transmits FCMC, which contains SC field as AID (1)=E8H, AID (2)=01H, AID (3)~AID (4)=FFH.</li> <li>5. The TE receives ACTC transmitted by the DUT (OBE).</li> <li>6. The TE verifies that the received ACTC is valid.</li> <li>7. The TE transmits FCMC, which contains SC field as AID (1)=E8H, AID (2)=F0H, AID (3)=01H, AID (4)=FFH.</li> <li>8. The TE receives ACTC transmitted by DUT (OBE).</li> <li>9. The TE verifies that the received ACTC is valid.</li> <li>10. The TE transmits FCMC, which contains SC field as AID (1)=E8H, AID (2)=F0H, AID (3)=E8H, AID (4)=01H.</li> <li>11. The TE receives ACTC transmitted by DUT (OBE).</li> <li>12. The TE verifies that the received ACTC is valid.</li> </ol>					
<b>Confirmation items</b>					
<ul style="list-style-type: none"> <li>• Verify that each LRI field of the received ACTC in test procedure 3, 6, 9 and 12 is as below table.</li> </ul>					
	ACTC.LRI	“b5”	“b6	“b7	“b8
	1st	“1”	“0”	“0”	“0”
	2nd	“0”	“1”	“0”	“0”
	3rd	“0”	“0”	“1”	“0”
	4th	“0”	“0”	“0”	“1”

Test number	2-1-5-2	Items	Basic operation: ACTC transmission – in case of reception of an FCMC registered AID(s) (2)
-------------	---------	-------	--

Test overview

Verify that an OBE that can transmit the ACTC conformed to the specification, that the LRI field should be set the comparison results between own AIDs and AIDs in FCMC transmitted from TE.

Test conditions

- Basic parameters shall be set as section 2.3.2.
- 4 SC profiles test as illustrated below table shall be conducted. Each test SC profile shall contain AID (AID=XX) to enable DUT (OBE) to response for it.

FCMC.SC	AID (1)	AID (2)	AID (3)	AID (4)
1st	XYH(AID=XX)	FFH	FFH	FFH
2nd	E8H (AID=29)	XYH(AID=XX)	FFH	FFH
3rd	E8H (AID=29)	F0H (AID=30)	XYH (AID=XX)	FFH
4th	E8H (AID=29)	F0H (AID=30)	E8H (AID=29)	XYH (AID=XX)

Test procedure

1. The TE transmits FCMC, which contains SC fields as AID (1)= XYH, AID (2)~AID (4)=FFH.
2. The TE receives ACTC transmitted by DUT (OBE).
3. The TE verifies that the received ACTC is valid.
4. The TE transmits FCMC, which contains SC fields as AID (1)=E8H, AID (2)= XYH, AID (3)~AID (4)=FFH.
5. The TE receives an ACTC transmitted by DUT (OBE).
6. The TE verifies that the received ACTC is valid.
7. The TE transmits FCMC, which contains SC fields as AID (1)=E8H, AID (2)=F0H, AID (3)= XYH, AID (4)=FFH.
8. The TE receives ACTC transmitted by DUT (OBE).
9. The TE verifies that the received ACTC is valid.
10. The TE transmits FCMC, which contains SC fields as AID (1)=E8H, AID (2)=F0H, AID (3)=E8H、 AID (4)= XYH.
11. The TE receives ACTC transmitted by DUT (OBE).
12. The TE verifies that the received ACTC is valid.

Confirmation items

- Verify that each LRI field of the received ACTC in test procedure 3, 6, 9 and 12 is as below table.

ACTC.LRI	“b5”	“b6	“b7	“b8
1st	“1”	“0”	“0”	“0”
2nd	“0”	“1”	“0”	“0”
3rd	“0”	“0”	“1”	“0”
4th	“0”	“0”	“0”	“1”

(Note) Actual AID field (XYH) of SC for the notified AID (XX) is determined as follow, the notified 5 bits AID is set to b4~b8 of AID field of SC (MSB first). The b2 and b3 field of correspond AID field is set to 0. The b1 field is extension indication bit and set to 1.

Test number	2-1-6	Items	Basic operation BST reception
Test overview			
Verify that the OBE could receive BST transmitted from Test Equipment and transmit an ack, which is contained in an ACKC, for it.			
Test conditions			
<ul style="list-style-type: none"> <li>• Basic parameters shall be set as section 2.3.2.</li> </ul>			
Test procedure			
<ol style="list-style-type: none"> <li>1. Transmit FCMCs from the TE (test equipment).</li> <li>2. The OBE transmits ACTC as response to the received FCMC from the TE.</li> <li>3. The TE registers the corresponding LID of the received ACTC at FCMC.</li> <li>4. Test Equipment transmits BST.</li> <li>5. Test Equipment receives an ACKC from the DUT (OBE)</li> </ol>			
Confirmation items			
<ul style="list-style-type: none"> <li>• Verify that UW2 (ASK)(Note) of ACKC is valid and AI indicates “an ack” in test procedure 5.</li> <li>• Verify that the CRC calculation result of received is valid in test procedure 5.</li> </ul>			

(Note) UW2 is UW2A in  $\pi/4$  shift QPSK method.

Test number	2-1-7	Items	Basic operation VST transmission
<b>Test overview</b> Verify that the OBE could receive BST transmitted from the Test Equipment and transmit VST for it.			
<b>Test conditions</b> <ul style="list-style-type: none"> <li>• Basic parameters shall be set as section 2.3.2.</li> </ul>			
<b>Test procedure</b> <ol style="list-style-type: none"> <li>1. The TE (test equipment). Transmits FCMC.</li> <li>2. The OBE transmits ACTC as response to the received FCMC from the TE.</li> <li>3. The TE registers corresponding LID of the received ACTC at FCMC.</li> <li>4. The TE transmits BST. Hereafter, the TE assigns UP-Link MDS slot for the DUT (OBE).</li> <li>5. The TE receives VST from the DUT (OBE).</li> <li>6. The TE transmits ACKC for the received VST as the verification results of it.</li> </ol>			
<b>Confirmation items</b> <ul style="list-style-type: none"> <li>• Verify that the ASN.1 format of the received VST is valid and the value of Profile and ApplicationList of its field is valid.</li> </ul>			

## 2-1-8 Initialization using communication profile(s)

Test number (item) depends on the own DUT (OBE) communication profile(s).

Test items for communication profile 11, 12 are not defined. These test items will be described.

Test number	DUT (OBE) communication profile(s)				
	communication profile 9	communication profile 10	communication profile 9 and 10	communication profile 11	communication profile 12
2-1-8-1	✓				
2-1-8-2			✓		
2-1-8-3		✓			
2-1-8-4		✓			
2-1-8-5			✓		
2-1-8-6	✓				
2-1-8-7	✓				
2-1-8-8		✓			
2-1-8-9			✓		

(Note1) The DUT (OBE) should take test number marked “✓”.

(Note2) IF the communication profile 10 has upper-compatibility with the communication profile 9, the DUT (OBE) shall take test numbers for communication profile 9 and 10.

Test number	2-1-8-1	Items	Basic operation Initialization using communication profile(s) (1)
<b>Test overview</b> Verify that the DUT (OBE) could valid response for own communication profile in case of receiving BST contained the TE communication profile.			
<b>Test conditions</b> <ul style="list-style-type: none"> <li>• The notified DUT (OBE) communication profile is 9.</li> <li>• The communication profile of BST transmitted from the TE is 9.</li> </ul>			
<b>Test procedure</b> <ol style="list-style-type: none"> <li>1. The TE (test equipment) transmits FCMCs.</li> <li>2. The DUT (OBE) transmits ACTC as response to the received FCMC from the TE.</li> <li>3. The TE registers corresponding LID of the received ACTC at the FCMC.</li> <li>4. The TE transmits BST contained communication profile. Hereafter, the TE assigns UP-Link MDS slot for the DUT (OBE).</li> <li>5. The TE receives VST from the DUT (OBE).</li> <li>6. The TE transmits ACKC for the received VST as the verification results of it.</li> </ol>			
<b>Confirmation items</b> <ul style="list-style-type: none"> <li>• Verify that the communication profile of VST is the same profile contained BST of the TE in test procedure 5.</li> <li>• The communication profile negotiated between the TE and the DUT (OBE) is 9.</li> </ul>			

Test number	2-1-8-2	Items	Basic operation: Initialization using communication profile(s) (2)
<b>Test overview</b> Verify that the DUT (OBE) could valid response for own communication profiles in case of receiving BST contained the TE communication profiles.			
<b>Test conditions</b> <ul style="list-style-type: none"> <li>• The notified DUT (OBE) communication profiles are 9 and 10.</li> <li>• The communication profile of BST transmitted from the TE is 9.</li> </ul>			
<b>Test procedure</b> <ol style="list-style-type: none"> <li>1. The TE (test equipment) transmits FCMC.</li> <li>2. The DUT (OBE) transmits ACTC as response to the received FCMC from the TE.</li> <li>3. The TE registers corresponding LID of the received ACTC at the FCMC.</li> <li>4. The TE transmits BST contained communication profile. Hereafter, the TE assigns UP-Link MDS slot for the DUT (OBE).</li> <li>5. The TE receives VST from the DUT (OBE).</li> <li>6. The TE transmits ACKC for the received VST as the verification results of it.</li> </ol>			
<b>Confirmation items</b> <ul style="list-style-type: none"> <li>• Verify that the communication profile of VST is the same profile contained BST of the TE in test procedure 5.</li> <li>• The communication profile negotiated between the TE and the DUT (OBE) is 9.</li> </ul>			

Test number	2-1-8-3	Items	Basic operation: Initialization using communication profile(s) (3)
Test overview			
Verify that the DUT (OBE) could valid response for own communication profile in case of receiving BST contained the TE communication profile.			
Test conditions			
<ul style="list-style-type: none"> <li>• The notified DUT (OBE) communication profile is 9.</li> <li>• The communication profile of BST transmitted from the TE is 10.</li> </ul>			
Test procedure			
<ol style="list-style-type: none"> <li>1. The TE (test equipment) transmits FCMCs.</li> <li>2. The DUT (OBE) transmits ACTC as response to the received FCMC from the TE.</li> <li>3. The TE registers corresponding LID of the received ACTC at the FCMC.</li> <li>4. The TE transmits BST contained communication profile, which the DUT (OBE) could not initialize for it. Hereafter, the TE assigns UP-Link MDS slot for the DUT (OBE).</li> <li>5. The DUT (OBE) verifies the BST parameters and does not transmit VST for BST. (Note)</li> </ol>			
Confirmation items			
<ul style="list-style-type: none"> <li>• Verify that The TE does not receive any VST form the DUT (OBE) in test procedure 5.</li> </ul>			

(Note) Hereafter, the DUT (OBE) will wait for new initialization procedure after expiration of re-lease timer. Therefore, the TE should set longer re-lease time than test period of this test item.

Test number	2-1-8-4	Items	Basic operation: Initialization using communication profile(s) (4)
<b>Test overview</b> Verify that the DUT (OBE) could valid response for own communication profile in case of receiving BST contained the TE communication profile.			
<b>Test conditions</b> <ul style="list-style-type: none"> <li>• The notified DUT (OBE) communication profile is 10.</li> <li>• The communication profile of BST transmitted from the TE is 10.</li> </ul>			
<b>Test procedure</b> <ol style="list-style-type: none"> <li>1. The TE (test equipment) transmits FCMC.</li> <li>2. The DUT (OBE) transmits ACTC as response to the received FCMC from the TE.</li> <li>3. The TE registers corresponding LID of the received ACTC at the FCMC.</li> <li>4. The TE transmits BST contained communication profile. Hereafter, the TE assigns UP-Link MDS slot for the DUT (OBE).</li> <li>5. The TE receives VST from the DUT (OBE).</li> <li>6. The TE transmits ACKC for the received VST as the verification results of it.</li> </ol>			
<b>Confirmation items</b> <ul style="list-style-type: none"> <li>• Verify that the communication profile of VST is the same profile, which is contained in BST of the TE in test procedure 5.</li> <li>• The communication profile negotiated between the TE and the DUT (OBE) is 10.</li> </ul>			

Test number	2-1-8-5	Items	Basic operation: Initialization using communication profile(s) (5)
<b>Test overview</b> Verify that the DUT (OBE) could valid response for own communication profile in case of receiving BST contained the TE communication profile.			
<b>Test conditions</b> <ul style="list-style-type: none"> <li>• The notified DUT (OBE) communication profiles are 9 and 10.</li> <li>• The communication profile of BST transmitted from the TE is 10.</li> </ul>			
<b>Test procedure</b> <ol style="list-style-type: none"> <li>1. The TE (test equipment) transmits FCMC.</li> <li>2. The DUT (OBE) transmits ACTC as response to the received FCMC from the TE.</li> <li>3. The TE registers corresponding LID of the received ACTC at the FCMC.</li> <li>4. The TE transmits BST contained communication profile. Hereafter, the TE assigns UP-Link MDS slot for the DUT (OBE).</li> <li>5. The TE receives VST from the DUT (OBE).</li> <li>6. The TE transmits ACKC for the received VST as the verification results of it.</li> </ol>			
<b>Confirmation items</b> <ul style="list-style-type: none"> <li>• Verify that the communication profile of VST is the same profile, which is contained in BST of the TE in test procedure 5.</li> <li>• The communication profile negotiated between the TE and the DUT (OBE) is 10.</li> </ul>			

Test number	2-1-8-6	Items	Basic operation: Initialization using communication profile(s) (6)
<b>Test overview</b> Verify that the DUT (OBE) could valid response for own communication profile in case of receiving BST contained the TE communication profile.			
<b>Test conditions</b> <ul style="list-style-type: none"> <li>• The notified DUT (OBE) communication profile is 9.</li> <li>• The communication profile of BST transmitted from the TE is 10.</li> </ul>			
<b>Test procedure</b> <ol style="list-style-type: none"> <li>1. The TE (test equipment) transmits FCMC.</li> <li>2. The DUT (OBE) transmits ACTC as response to the received FCMC from the TE.</li> <li>3. The TE registers corresponding LID of the received ACTC at the FCMC.</li> <li>4. The TE transmits BST contained communication profile, which the DUT (OBE) could not initialize for it. Hereafter, the TE assigns UP-Link MDS slot for the DUT (OBE).</li> <li>5. The DUT (OBE) verifies the BST parameters and does not VST for BST. (Note)</li> </ol>			
<b>Confirmation items</b> <ul style="list-style-type: none"> <li>• Verify that The TE does not receive any VST form the DUT (OBE) in test procedure 5.</li> </ul>			

(Note) Hereafter, the DUT (OBE) will wait for new initialization procedure after expiration of re-lease timer. The TE should be set longer re-lease time than test period of this test item.

Test number	2-1-8-7	Items	Basic operation: Initialization using communication profile(s) (7)
<b>Test overview</b> Verify that the DUT (OBE) could valid response for own communication profile in case of receiving BST contained the TE communication profiles.			
<b>Test conditions</b> <ul style="list-style-type: none"> <li>• The notified DUT (OBE) communication profile is 9.</li> <li>• The communication profiles of BST transmitted from the TE as follows; profile is 9 and profile list is 10.</li> </ul>			
<b>Test procedure</b> <ol style="list-style-type: none"> <li>1. The TE (test equipment) transmits FCMC.</li> <li>2. The DUT (OBE) transmits ACTC as response to the received FCMC from the TE.</li> <li>3. The TE registers corresponding LID of the received ACTC at the FCMC.</li> <li>4. The TE transmits BST contained communication profiles. Hereafter, the TE assigns UP-Link MDS slot for the DUT (OBE).</li> <li>5. The TE receives VST from the DUT (OBE).</li> <li>6. The TE transmits ACKC for the received VST as the verification results of it.</li> </ol>			
<b>Confirmation items</b> <ul style="list-style-type: none"> <li>• Verify that the communication profile of VST is one of the same profiles contained BST of the TE in test procedure 5.</li> <li>• The communication profile negotiated between the TE and the DUT (OBE) is 9.</li> </ul>			

Test number	2-1-8-8	Items	Basic operation: Initialization using communication profile(s) (8)
<b>Test overview</b> Verify that the DUT (OBE) could valid response for own communication profile in case of receiving BST contained the TE communication profiles.			
<b>Test conditions</b> <ul style="list-style-type: none"> <li>• The notified DUT (OBE) communication profile is 10.</li> <li>• The communication profiles of BST transmitted from the TE as follows; profile is 9 and profile list is 10.</li> </ul>			
<b>Test procedure</b> <ol style="list-style-type: none"> <li>1. The TE (test equipment) transmits FCMC.</li> <li>2. The DUT (OBE) transmits ACTC as response to the received FCMC from the TE.</li> <li>3. The TE registers corresponding LID of the received ACTC at the FCMC.</li> <li>4. The TE transmits BST contained communication profiles. Hereafter, the TE assigns UP-Link MDS slot for the DUT (OBE).</li> <li>5. The TE receives VST from the DUT (OBE).</li> <li>6. The TE transmits ACKC for the received VST as the verification results of it.</li> </ol>			
<b>Confirmation items</b> <ul style="list-style-type: none"> <li>• Verify that the communication profile of VST is one of profiles, which are contained in BST of the TE in test procedure 5.</li> <li>• The communication profile negotiated between the TE and the DUT (OBE) is 9.</li> </ul>			

Test number	2-1-8-9	Items	Basic operation: Initialization using communication profile(s) (9)
<p><b>Test overview</b></p> <p>Verify that the DUT (OBE) could valid response for own communication profiles in case of receiving BST contained the TE communication profiles.</p>			
<p><b>Test conditions</b></p> <ul style="list-style-type: none"> <li>• The notified DUT (OBE) communication profiles are 9 and 10.</li> <li>• The communication profiles of BST transmitted from the TE as follows; profile is 9 and profile list is 10.</li> </ul>			
<p><b>Test procedure</b></p> <ol style="list-style-type: none"> <li>1. The TE (test equipment) transmits FCMC.</li> <li>2. The DUT (OBE) transmits ACTC as response to the received FCMC from the TE.</li> <li>3. The TE registers corresponding LID of the received ACTC at the FCMC.</li> <li>4. The TE transmits BST contained communication profiles. Hereafter, the TE assigns UP-Link MDS slot for the DUT (OBE).</li> <li>5. The TE receives VST from the DUT (OBE).</li> <li>6. The TE transmits ACKC for the received VST as the verification results of it.</li> </ol>			
<p><b>Confirmation items</b></p> <ul style="list-style-type: none"> <li>• Verify that the communication profile of VST is one of profiles, which are contained in BST of the TE in test procedure 5.</li> <li>• The communication profile negotiated between the TE and the DUT (OBE) is 9.</li> </ul>			

Test number	2-1-9	Items	Basic operation Termination Procedure 1
Test overview			
Verify that the DUT (OBE) could re-start initialization procedure, the transmission of ACTC, after receiving release command from the TE.			
Test conditions			
<ul style="list-style-type: none"> <li>• Basic parameters shall be set as section 2.3.2.</li> </ul>			
Test procedure			
<ol style="list-style-type: none"> <li>1. The TE (test equipment) transmits FCMC.</li> <li>2. The DUT (OBE) transmits ACTC as response to the received FCMC from the TE.</li> <li>3. The TE registers corresponding LID of the received ACTC at the FCMC.</li> <li>4. The TE transmits BST. Hereafter, the TE assigns UP-Link MDS slot for the DUT (OBE).</li> <li>5. The TE receives VST from the DUT (OBE).</li> <li>6. The TE transmits the release command.</li> <li>7. The TE (test equipment) transmits FCMC, at which dose not register the corresponding DUT (OBE) LID.</li> <li>8. The TE receives ACTC from the DUT (OBE). The TE starts the ACTC reception procedure after expiration of 80% of the lease time from the FCMC transmission in procedure 6.</li> </ol>			
Confirmation items			
<ul style="list-style-type: none"> <li>• Verify that UW2 (ASK) (Note1), FID and LRI of ACTC are valid in test procedure 8.</li> <li>• Verify that the DUT (OBE) transmits ACTC within the specified time (+20% of (the connection time + the release time)) in test procedure 8 after the transmission of the release command from the TE in test procedure 6. (Note 2)</li> </ul>			

(Note1) UW2 is UW2A in  $\pi/4$  shift QPSK method.

(Note2) This test aim is the verification that the termination procedure in the previous sequence was conducted normally through checking the re-reception of ACTC from the DUT (OBE). Therefore, the ACTC response time is guideline and it is not precisely measured.

Test number	2-1-10	Items	Basic operation Termination Procedure 2
Test overview			
Verify that the DUT (OBE) could re-start initialization procedure, the transmission of ACTC, in case of that the TE does not transmit release command.			
Test conditions			
<ul style="list-style-type: none"> <li>• Basic parameters shall be set as section 2.3.2.</li> </ul>			
Test procedure			
<ol style="list-style-type: none"> <li>1. The TE (test equipment) transmits FCMC.</li> <li>2. The DUT (OBE) transmits ACTC as response to the received FCMC from the TE.</li> <li>3. The TE registers corresponding LID of the received ACTC at the FCMC.</li> <li>4. The TE transmits BST. Hereafter, the TE assigns UP-Link MDS slot for the DUT (OBE).</li> <li>5. The TE receives VST from the DUT (OBE).</li> <li>6. The TE does not transmit the release command and transmits FCMC, at which dose not register the corresponding DUT (OBE) LID.</li> <li>7. The TE receives ACTC from the DUT (OBE).</li> </ol>			
Confirmation items			
<ul style="list-style-type: none"> <li>• Verify that UW2 (ASK) (Note1), FID and LRI of ACTC are valid in test procedure 7.</li> <li>• Verify that the DUT (OBE) transmits ACTC within the specified time (+20% of (the connection time + the release time)) in test procedure 7 after the transmission of the FCMC from the TE in test procedure 6.</li> </ul>			

(Note1) UW2 is UW2A in  $\pi/4$  shift QPSK method.

(Note2) This test aim is the verification that the termination procedure in the previous sequence is conducted normally through checking the re-reception of ACTC from the DUT (OBE). Therefore, the ACTC response time is guideline and it is not precisely measured.

Test number	2-1-11	Items	Basic operation Transaction test using PDU
Test overview Verify that transaction is conducted using PDU.			
Test conditions <ul style="list-style-type: none"> <li>• Basic parameters shall be set as section 2.3.2.</li> <li>• Attribute for TestData1 refers to TEST Attributes in Annex 2.</li> </ul>			
Test procedure <ol style="list-style-type: none"> <li>1. Initialization procedure (BST/VST exchange) should be conducted.</li> <li>2. The TE transmits the Set primitive PDU, which contains TestData1 generated randomly. The DUT (OBE) receives the Set primitive PDU and writes its data to Attribute for TestData1.</li> <li>3. The TE transmits the Get primitive PDU to read Attribute for TestData1 of The DUT (OBE). The DUT (OBE) reads it and sends to the TE.</li> <li>4. The TE transmits the release command.</li> </ol>			
Confirmation items <ul style="list-style-type: none"> <li>• Verify that the readout data in procedure 3 is the same as the written data in procedure 2.</li> </ul>			

Test number	2-1-12	Items	Basic operation Transaction test using plural PDUs
Test overview Verify that transaction is conducted using PDU without duplication.			
Test conditions <ul style="list-style-type: none"> <li>• Basic parameters shall be set as section 2.3.2.</li> <li>• Attribute for TestData1 refers to TEST Attributes in Annex 2.</li> </ul>			
Test procedure <ol style="list-style-type: none"> <li>1. Initialization procedure (BST/VST exchange) should be conducted.</li> <li>2. The TE transmits the Set primitive PDU, which contains TestData1 generated randomly. The DUT (OBE) receives the Set primitive PDU and writes its data to Attribute for TestData1.</li> <li>3. The TE transmits the Get primitive PDU to read Attribute for TestData1 of The DUT (OBE). The DUT (OBE) reads it and sends to the TE.</li> <li>4. The TE resets the written data and repeats procedures 2 and 3 repeats 15 times after incrementing the MAC control field SEQ Number in each transaction.</li> <li>5. The TE transmits the release command.</li> </ol>			
Confirmation items <ul style="list-style-type: none"> <li>• Verify that the readout data in procedure 3 is the same as the written data in procedure 2.</li> </ul>			

Test number	2-1-13	Items	Basic operation Transaction test – duplication check of PDU
Test overview			
Verify that the duplicated MPDU could reject using SEQ number of PDU.			
Test conditions			
<ul style="list-style-type: none"> <li>• Basic parameters shall be set as section 2.3.2.</li> <li>• Attribute for TestData1 refers to TEST Attributes in Annex 2.</li> </ul>			
Test procedure			
<ol style="list-style-type: none"> <li>1. Initialization procedure (BST/VST exchange) is conducted between the TE and the DUT (OBE).</li> <li>2. The TE transmits the Set primitive PDU, which contains TestData1 generated randomly. The DUT (OBE) receives the Set primitive PDU and writes its data to Attribute for TestData1.</li> <li>3. The TE transmits the Get primitive PDU to read Attribute for TestData1 of The DUT (OBE). The DUT (OBE) reads it and sends to the TE.</li> <li>4. The TE resets the written data and repeats procedures 2. The MAC control field SEQ Number is not incremented in each transaction. Hereafter, the procedure 3 is conducted.</li> <li>5. The TE transmits the release command.</li> </ol>			
Confirmation items			
<ul style="list-style-type: none"> <li>• Verify that the readout data in first test procedure 3 using Get primitive is the same as the written data in last test procedure 2 using Set primitive.</li> </ul>			

Test number	2-1-14	Items	Basic operation Transaction test – OBE retransmission
<p>Test overview</p> <p>Verify that the DUT (OBE) could retransmit the same PDU in case of transmitting ACKC, which indicates a nak for a previous received PDU.</p> <p>Verify the behavior of the DUT (OBE) when the TE does not transmit ACKC for a PDU sent from the DUT (OBE).</p>			
<p>Test conditions</p> <ul style="list-style-type: none"> <li>• Basic parameters shall be set as section 2.3.2.</li> <li>• Attribute for TestData1 refers to TEST Attributes in Annex 2.</li> </ul>			
<p>Test procedure</p> <ol style="list-style-type: none"> <li>1. Initialization procedure (BST/VST exchange) is conducted between the TE and the DUT (OBE).</li> <li>2. The TE transmits the Set primitive PDU, which contains TestData1 generated randomly. The DUT (OBE) receives the Set primitive PDU and writes its data to Attribute for TestData1.</li> <li>3. The TE transmits the Get primitive PDU to read Attribute for TestData1 of The DUT (OBE). The DUT (OBE) reads it and sends to the TE in an assigned uplink slot.</li> <li>4. The TE receives the PDU sent from the DUT (OBE) and sends ACKC, which indicates a nak.</li> <li>5. The TE re-assigns the uplink slot and the DUT (OBE) sends the PDU. Hereafter, The TE receives it and sends ACKC, which indicates an ack, for the received PDU.</li> <li>6. The TE transmits the Set primitive PDU, which contains TestData1 generated randomly. The DUT (OBE) receives the Set primitive PDU and writes its data to Attribute for TestData1.</li> <li>7. The TE transmits the Get primitive PDU to read Attribute for TestData1 of The DUT (OBE). The DUT (OBE) reads it and sends to the TE in an assigned uplink slot.</li> <li>8. The TE receives the PDU from the DUT (OBE) and does not send ACKC for it.</li> <li>9. The TE re-assigns the uplink slot and the DUT (OBE) sends the PDU. Hereafter, The TE receives it and sends ACKC, which indicates an ack, for the received PDU.</li> <li>10. The TE transmits the release command.</li> </ol>			
<p>Confirmation items</p> <ul style="list-style-type: none"> <li>• Verify that the readout data in test procedure 5 using Get primitive is the same as the written data in test procedure 2 using Set primitive.</li> <li>• Verify that the readout data in test procedure 9 using Get primitive is the same as the written data in test procedure 6 using Set primitive.</li> </ul>			

Test number	2-1-15	Items	Basic operation Transaction test – OBE retransmission request for TE
Test overview			
Verify that the DUT (OBE) could transmit ACKC, which indicates a nak, in case of receiving invalid PDU.			
Test conditions			
<ul style="list-style-type: none"> <li>• Basic parameters shall be set as section 2.3.2.</li> <li>• Attribute for TestData1 refers to TEST Attributes in Annex 2.</li> </ul>			
Test procedure			
<ol style="list-style-type: none"> <li>1. Initialization procedure (BST/VST exchange) is conducted between the TE and the DUT (OBE).</li> <li>2. The TE transmits the Set primitive PDU, which contains TestData1 generated randomly and the FRG field of MAC is set to 1 and C/L field of MAC is set to 1. The DUT (OBE) receives the Set primitive PDU and writes its data to Attribute for TestData1.</li> <li>3. The TE receives ACKC form the DUT (OBE).</li> <li>4. The TE transmits the Set primitive next PDU, which contains TestData1 generated randomly and the MAC field is set normally. The DUT (OBE) receives the Set primitive PDU and writes its data to Attribute for TestData1.</li> <li>5. The TE transmits the Get primitive PDU to read Attribute for TestData1 of The DUT (OBE). The DUT (OBE) reads it and sends to the TE in an assigned uplink slot.</li> <li>6. The TE transmits the release command.</li> </ol>			
Confirmation items			
<ul style="list-style-type: none"> <li>• Verify that AI of the received ACKC indicates a nak.</li> <li>• Verify that the readout data in test procedure 5 using Get primitive is the same as the written data in test procedure 4 using Set primitive.</li> </ul>			

Test number	2-1-16	Items	Basic operation WCNC transmission
Test overview			
Verify that the DUT (OBE) could transmit WCNC.			
Test conditions			
<ul style="list-style-type: none"> <li>• Basic parameters shall be set as section 2.3.2.</li> </ul>			
Test procedure			
<ol style="list-style-type: none"> <li>1. Initialization procedure (BST/VST exchange) is conducted between the TE and the DUT</li> <li>2. The TE transmits the release command.</li> <li>3. The TE transmits FCMC assigned uplink slot for WCNS.</li> </ol>			
Confirmation items			
<ul style="list-style-type: none"> <li>• Verify that the DUT (OBE) could transmit WCNC.</li> </ul>			

Test number	2-1-17	Items	Basic operation ACTC transmission control by STA in FCMC (Note)
Test overview			
Verify that the ACTC transmission numbers varies depending on the activation (acceptance) state of the ACTC.			
Test conditions			
<ul style="list-style-type: none"> <li>Basic parameters shall be set as section 2.3.2.</li> </ul>			
Test procedure			
<ol style="list-style-type: none"> <li>The TE transmits FCMC, in which STA indicates the activation probability is from 50% to 100% and FID is 1.</li> <li>The TE receives ACTCs, but does not register corresponding LID at FCMC.</li> <li>The TE transmits FCMC, in which STA indicates the activation probability is from 25% to less than 50% and FID is 2.</li> <li>The TE receives ACTCs, but does not register corresponding LID at FCMC.</li> <li>The TE transmits FCMC, in which STA indicates the activation probability is from 12.5% to less than 25% and FID is 3.</li> <li>The TE receives ACTCs, but does not register corresponding LID at FCMC.</li> <li>The TE transmits FCMC, in which STA indicates the activation probability is less than 12.5% and FID is 4.</li> <li>The TE receives ACTCs, but does not register corresponding LID at FCMC.</li> </ol>			
Confirmation items			
<ul style="list-style-type: none"> <li>Verify that the DUT (OBE) transmits an ACTC for response to every FCMC in test procedure 2.</li> <li>Verify that the DUT (OBE) transmits an ACTC for response to every other FCMC in test procedure 4.</li> <li>Verify that the DUT (OBE) transmits an ACTC for response to every 4 times FCMC in test procedure 6 and 8.</li> </ul>			

Test number	2-1-18-1	Items	Basic operation Transaction test – fragmentation and de-fragmentation of PDU (ASK)(Note)
Test overview			
Verify that the DUT (OBE) could send fragmented PDUs and receive de-fragmented PDU.			
Test conditions			
<ul style="list-style-type: none"> <li>• Basic parameters shall be set as section 2.3.2.</li> <li>• Attributes for TestData1, TestData2, TestData3 and TestData4 refer to TEST Attributes in Annex 2.</li> </ul>			
Test procedure			
<ol style="list-style-type: none"> <li>1. Initialization procedure (BST/VST exchange) is conducted between the TE and the DUT (OBE).</li> <li>2. The TE transmits Set primitive PDUs, which contains randomly generated TestData1, TestData2, TestData3 and TestData4 to have enough PDU length to enable fragment. The DUT (OBE) receives the Set primitive PDU and writes its data to Attribute for TestData1, TestData2, TestData3 and TestData4.</li> <li>3. The TE transmits Get primitive PDUs to read Attributes for TestData2, TestData3 and TestData4 of The DUT (OBE). The DUT (OBE) reads them and sends to the TE in an assigned uplink slots.</li> <li>4. Repeats the procedure 2 and 3 more than 15 times.</li> <li>5. The TE transmits the release command.</li> </ol>			
Confirmation items			
<ul style="list-style-type: none"> <li>• Verify that the readout data in test procedure 3 using Get primitive is the same as the written data in test procedure 2 using Set primitive.</li> </ul>			

Test number	2-1-18-2	Items	Basic operation Transaction test–fragmentation and de-fragmentation of PDU $\pi/4$ shift QPSK) (Note)
Test overview			
Verify that the DUT (OBE) could send fragmented PDUs and receive de-fragmented PDU.			
Test conditions			
<ul style="list-style-type: none"> <li>• Basic parameters shall be set as section 2.3.2.</li> <li>• Attributes for TestData5 and TestData6 refer to TEST Attributes in Annex 2.</li> </ul>			
Test procedure			
<ol style="list-style-type: none"> <li>1. Initialization procedure (BST/VST exchange) is conducted between the TE and the DUT (OBE).</li> <li>2. The TE transmits the Set primitive PDUs, which contains randomly generated TestData5 and TestData6 to have enough PDU length to enable fragment.</li> <li>3. The TE transmits the Get primitive PDUs to read Attributes for TestData5 and TestData6 of The DUT (OBE). The DUT (OBE) reads them and sends to the TE in an assigned uplink slots.</li> <li>4. Repeats the procedure 2 and 3 more than 15 times.</li> <li>5. The TE transmits the release command.</li> </ol>			
Confirmation items			
<ul style="list-style-type: none"> <li>• Verify that the readout data in test procedure 3 using Get primitive is the same as the written data in test procedure 2 using Set primitive.</li> </ul>			

Test number	2-1-19	Items	Basic operation Termination Procedure 3 (Note)
<p>Test overview</p> <p>Verify that the DUT (OBE) restart initialization (transmission of ACTC) after receiving release command from the TE.</p>			
<p>Test conditions</p> <ul style="list-style-type: none"> <li>• Basic parameters shall be set as section 2.3.2.</li> <li>• Release time is 10 seconds.</li> <li>• The validation field of RLT is always valid.</li> </ul>			
<p>Test procedure</p> <ol style="list-style-type: none"> <li>1. The TE transmits FCMC.</li> <li>2. The DUT (OBE) transmits ACTC as response for FCMC.</li> <li>3. The TE receives ACTC and registers the corresponding LID at FCMC.</li> <li>4. The TE transmits BST and assigns uplink MDS slot.</li> <li>5. The DUT (OBE) transmits VST as response for BST.</li> <li>6. The TE transmits release command.</li> <li>7. The TE transmits FCMCs, at which the corresponding LID does not register.</li> <li>8. The TE receives ACTC from the DUT (OBE). The TE starts the ACTC reception procedure after expiration of 80% of the lease time from the FCMC transmission in procedure 6.</li> </ol>			
<p>Confirmation items</p> <ul style="list-style-type: none"> <li>• Verify that UW2 (ASK) (Note1), FID and LRI of ACTC are valid in test procedure 8.</li> <li>• Verify that the DUT (OBE) transmits ACTC within the specified time (+20% of (the connection time + the release time)) in test procedure 8 after the transmission of the release command from the TE in test procedure 6. (Note 2)</li> </ul>			

(Note1) UW2 is UW2A in  $\pi/4$  shift QPSK method.

(Note2) This test aim is the verification that the termination procedure in the previous sequence was conducted normally through checking the re-reception of ACTC from the DUT (OBE). Therefore, the ACTC response time is guideline and it is not precisely measured.

Test number	2-1-20	Items	Basic operation Re-initialization in case of reception of release (Note)
<p>Test overview</p> <p>Verify that the DUT (OBE) restart initialization (transmission of ACTC) after receiving RLT of FCMC, in which indicates invalid of release timer.</p>			
<p>Test conditions</p> <ul style="list-style-type: none"> <li>• Basic parameters shall be set as section 2.3.2.</li> <li>• Release time is 600 seconds.</li> </ul>			
<p>Test procedure</p> <ol style="list-style-type: none"> <li>1. The TE transmits FCMC.</li> <li>2. The DUT (OBE) transmits ACTC as response for FCMC.</li> <li>3. The TE receives ACTC and registers the corresponding LID at FCMC.</li> <li>4. The TE transmits BST and assigns uplink MDS slot.</li> <li>5. The DUT (OBE) transmits VST as response for BST.</li> <li>6. The TE transmits release command.</li> <li>7. The TE transmits FCMCs, at which the corresponding LID does not register.</li> <li>8. The TE transmits FCMC contained RLT, in which indicates invalid of release timer after expiration of 30 seconds from test procedure 6.</li> <li>9. The TE receives ACTC from the DUT (OBE).</li> </ol>			
<p>Confirmation items</p> <ul style="list-style-type: none"> <li>• Verify that UW2 (ASK) (Note), FID and LRI of ACTC are valid in test procedure 9.</li> <li>• Verify in test procedure 9 that the DUT (OBE) transmits ACTC in the same frame or next frame, in which contains the FCMC indicated invalid of release timer in test procedure 8.</li> </ul>			

(Note) UW2 is UW2A in  $\pi/4$  shift QPSK method.

Test number	2-1-21	Items	Basic operation Reception of PDU addressed multicast (group) address
<b>Test overview</b> Verify that the DUT (OBE) could receive PDU addressed multicast (group) address from the TE.			
<b>Test conditions</b> <ul style="list-style-type: none"> <li>• Basic parameters shall be set as section 2.3.2.</li> <li>• The multicast (group) address is notified address of the DUT (OBE).</li> <li>• The EID is 127 for multicast test. (Note1)</li> <li>• Attribute for TestData1 refers to TEST Attributes in Annex 2.</li> </ul>			
<b>Test procedure</b> <ol style="list-style-type: none"> <li>1. The TE transmits the Set primitive PDUs, which contains randomly generated TestData1 addressed multicast (group) address. The DUT (OBE) receives the Set primitive PDU and writes its data to write Attribute for TestData1. (Note2)</li> <li>2. Initialization procedure (BST/VST exchange) is conducted between the TE and the DUT (OBE).</li> <li>3. The TE transmits the Get primitive PDUs to read Attributes for TestData1 of The DUT (OBE). The DUT (OBE) reads them and sends to the TE in an assigned uplink slots.</li> <li>4. The TE transmits the release command.</li> </ol>			
<b>Confirmation items</b> <ul style="list-style-type: none"> <li>• Verify that the readout data in test procedure 3 using Get primitive is the same as the written data in test procedure 1 using Set primitive.</li> </ul>			

(Note1) Defined EID for this test is used, since the PDU(s) addressed multicast (group) address shall be received before initialization (the confirmation of EID(s)).

(Note2) Test procedure 1 should maintain during several frame period and hereafter proceeds test procedure 2, since the acknowledgement procedure, between the TE and the DUT (OBE), for transmission of the Set primitive PDU(s) addressed multicast (group) address is not conducted.

Test number	2-1-22	Items	Basic operation Reception of PDU addressed broadcast address
Test overview			
Verify that the DUT (OBE) could receive PDU addressed broadcast address from the TE.			
Test conditions			
<ul style="list-style-type: none"> <li>• Basic parameters shall be set as section 2.3.2.</li> <li>• The EID is 127 for multicast test. (Note1)</li> <li>• Attribute for TestData1 refers to TEST Attributes in Annex 2.</li> </ul>			
Test procedure			
<ol style="list-style-type: none"> <li>1. The TE transmits the Set primitive PDUs, which contains randomly generated TestData1 addressed broadcast address. The DUT (OBE) receives the Set primitive PDU and writes its data to attribute for TestData1. (Note2)</li> <li>2. Initialization procedure (BST/VST exchange) is conducted between the TE and the DUT (OBE).</li> <li>3. The TE transmits the Get primitive PDUs to read Attributes for TestData1 of The DUT (OBE). The DUT (OBE) reads them and sends to the TE in an assigned uplink slots.</li> <li>4. The TE transmits the release command.</li> </ol>			
Confirmation items			
<ul style="list-style-type: none"> <li>• Verify that the readout data in test procedure 3 using Get primitive is the same as the written data in test procedure 1 using Set primitive.</li> </ul>			

(Note1) Defined EID for this test is used. Since the PDU(s) addressed broadcast address shall be received before initialization (the confirmation of EID(s)).

(Note2) Test procedure 1 should maintain during several frame period and hereafter proceeds test procedure 2, since the acknowledgement procedure, between the TE and the DUT (OBE), for transmission of the Set primitive PDU(s) addressed broadcast address is not conducted.

2.3.3.2.2 Propagation simulation field operation test

Test number	2-2-1-1	Items	Propagation simulation field operation Normal speed Propagation simulation field operation test - ideal profile - maximum input power at an OBE
Test overview Communication protocol test under propagation simulation field test			
Test conditions <ul style="list-style-type: none"> <li>• Test Application Program: Basic Test Program (Refer to Annex 2)</li> <li>• Basic Parameters: Parameters as per section 2.3.2.</li> <li>• Propagation profile: 1-1</li> <li>• Communication sequence: The sequence as per section 2.3.2.5.</li> </ul>			
Test procedure <ol style="list-style-type: none"> <li>1. Conducts the communication sequence between the test equipment and the OBE.</li> <li>2. Repeats 100 sequences</li> </ol>			
Confirmation items <ul style="list-style-type: none"> <li>• The communication sequence is conducted in conformance with specification.</li> </ul>			

Test number	2-2-1-2	Items	Propagation simulation field operation Normal speed Propagation simulation field operation test – ideal profile - minimum input power at an OBE
Test overview Communication protocol test under propagation simulation field test			
Test conditions <ul style="list-style-type: none"> <li>• Test Application Program: Basic Test Program (Refer to Annex 2)</li> <li>• Basic Parameters: Parameters as per section 2.3.2.</li> <li>• Propagation profile: 1-2</li> <li>• Communication sequence: The sequence as per section 2.3.2.5</li> </ul>			
Test procedure <ol style="list-style-type: none"> <li>1. Conducts the communication sequence between the test equipment and the OBE.</li> <li>2. Repeats 100 sequences</li> </ol>			
Confirmation items <ul style="list-style-type: none"> <li>• The communication sequence is conducted in conformance with specification.</li> </ul>			

Test number	2-2-1-3	Items	Propagation simulation field operation Normal speed Propagation simulation field operation test – practical profile A
Test overview Communication protocol test under propagation simulation field test			
Test conditions <ul style="list-style-type: none"> <li>• Test Application Program: Basic Test Program (Refer to Annex 2)</li> <li>• Basic Parameters: Parameters as per section 2.3.2.</li> <li>• Propagation profile: 2-1</li> <li>• Communication sequence: The sequence as per section 2.3.2.5</li> </ul>			
Test procedure <ol style="list-style-type: none"> <li>1. Conducts the communication sequence between the test equipment and the OBE.</li> <li>2. Repeats 100 sequences</li> </ol>			
Confirmation items <ul style="list-style-type: none"> <li>• The communication sequence is conducted in conformance with specification.</li> </ul>			

Test number	2-2-1-4	Items	Propagation simulation field operation Normal speed Propagation simulation field operation test – practical profile B
Test overview Communication protocol test under propagation simulation field test			
Test conditions <ul style="list-style-type: none"> <li>• Test Application Program: Basic Test Program (Refer to Annex 2)</li> <li>• Basic Parameters: Parameters as per section 2.3.2.</li> <li>• Propagation profile: 2-2</li> <li>• Communication sequence: The sequence as per section 2.3.2.5</li> </ul>			
Test procedure <ol style="list-style-type: none"> <li>1. Conducts the communication sequence between the test equipment and the OBE.</li> <li>2. Repeats 100 sequences</li> </ol>			
Confirmation items <ul style="list-style-type: none"> <li>• The communication sequence is conducted in conformance with specification.</li> </ul>			

Test number	2-2-1-5	Items	Propagation simulation field operation Normal speed Propagation simulation field operation test – adjacent lane passing profile
Test overview Communication protocol test under propagation simulation field test			
Test conditions <ul style="list-style-type: none"> <li>• Test Application Program: Basic Test Program (Refer to Annex 2)</li> <li>• Basic Parameters: Parameters as per section 2.3.2.</li> <li>• Propagation profile: 3</li> </ul>			
Test procedure <ol style="list-style-type: none"> <li>1. Transmits FCMC from the TE</li> <li>2. Repeats 100 sequences</li> </ol>			
Confirmation items <ul style="list-style-type: none"> <li>• The DUT (OBE) does not transmit any ACTC.</li> </ul>			

Test number	2-2-1-6	Items	Propagation simulation field operation Normal speed Propagation simulation field operation test –shadowing profile
Test overview Communication protocol test under propagation simulation field test			
Test conditions <ul style="list-style-type: none"> <li>• Test Application Program: Basic Test Program (Refer to Annex 2)</li> <li>• Basic Parameters: Parameters as per section 2.3.2.</li> <li>• Propagation profile: 4</li> <li>• Communication sequence: The sequence specified in section 2.3.2.5</li> </ul>			
Test procedure <ol style="list-style-type: none"> <li>1. Conducts the communication sequence between the test equipment and the OBE.</li> <li>2. Repeats 100 sequences</li> </ol>			
Confirmation items <ul style="list-style-type: none"> <li>• The communication sequence is conducted in conformance with specification.</li> </ul>			

Test number	2-2-2-1	Items	Propagation simulation field operation Low speed Propagation simulation field operation test - ideal profile - maximum input power at an OBE
Test overview Communication protocol test under propagation simulation field test			
Test conditions <ul style="list-style-type: none"> <li>• Test Application Program: Basic Test Program (Refer to Annex 2)</li> <li>• Basic Parameters: Parameters as per section 2.3.2.</li> <li>• Propagation profile: 5-1</li> <li>• Communication sequence: The sequence specified in section 2.3.2.5</li> </ul>			
Test procedure <ol style="list-style-type: none"> <li>1. Conducts the communication sequence between the test equipment and the OBE.</li> <li>2. Repeats 100 sequences</li> </ol>			
Confirmation items <ul style="list-style-type: none"> <li>• The communication sequence is conducted in conformance with specification.</li> </ul>			

Test number	2-2-2-2	Items	Propagation simulation field operation Low speed Propagation simulation field operation test – ideal profile – minimum input power at an OBE
Test overview Communication protocol test under propagation simulation field test			
Test conditions <ul style="list-style-type: none"> <li>• Test Application Program: Basic Test Program (Refer to Annex 2)</li> <li>• Basic Parameters: Parameters as per section 2.3.2.</li> <li>• Propagation profile: 5-2</li> <li>• Communication sequence: The sequence specified in section 2.3.2.5</li> </ul>			
Test procedure <ol style="list-style-type: none"> <li>1. Conducts the communication sequence between the test equipment and the OBE.</li> <li>2. Repeats 100 sequences</li> </ol>			
Confirmation items <ul style="list-style-type: none"> <li>• The communication sequence is conducted in conformance with specification.</li> </ul>			

Test number	2-2-2-3	Items	Propagation simulation field operation Low speed Propagation simulation field operation test – practical profile A
Test overview Communication protocol test under propagation simulation field test			
Test conditions <ul style="list-style-type: none"> <li>• Test Application Program: Basic Test Program (Refer to Annex 2)</li> <li>• Basic Parameters: Parameters as per section 2.3.2.</li> <li>• Propagation profile: 6-1</li> <li>• Communication sequence: The sequence specified in section 2.3.2.5</li> </ul>			
Test procedure <ol style="list-style-type: none"> <li>1. Conducts the communication sequence between the test equipment and the OBE.</li> <li>2. Repeats 100 sequences</li> </ol>			
Confirmation items <ul style="list-style-type: none"> <li>• The communication sequence is conducted in conformance with specification.</li> </ul>			

Test number	2-2-2-4	Items	Propagation simulation field operation Low speed Propagation simulation field operation test – practical profile B
Test overview Communication protocol test under propagation simulation field test			
Test conditions <ul style="list-style-type: none"> <li>• Test Application Program: Basic Test Program (Refer to Annex 2)</li> <li>• Basic Parameters: Parameters as per section 2.3.2.</li> <li>• Propagation profile: 6-2</li> <li>• Communication sequence: The sequence specified in section 2.3.2.5</li> </ul>			
Test procedure <ol style="list-style-type: none"> <li>1. Conducts the communication sequence between the test equipment and the OBE</li> <li>2. Repeats 100 sequences</li> </ol>			
Confirmation items <ul style="list-style-type: none"> <li>• The communication sequence is conducted in conformance with specification.</li> </ul>			

Test number	2-2-2-5	Items	Propagation simulation field operation Low speed Propagation simulation field operation test –adjacent lane passing profile
Test overview Communication protocol test under propagation simulation field test			
Test conditions <ul style="list-style-type: none"> <li>• Test Application Program: Basic Test Program (Refer to Annex 2)</li> <li>• Basic Parameters: Parameters as per section 2.3.2.</li> <li>• Propagation profile: 7</li> </ul>			
Test procedure <ol style="list-style-type: none"> <li>1. Transmits FCMC from the TE</li> <li>2. Repeats 100 sequences</li> </ol>			
Confirmation items <ul style="list-style-type: none"> <li>• The DUT (OBE) does not transmit any ACTC.</li> </ul>			

Test number	2-2-2-6	Items	Propagation simulation field operation Low speed Propagation simulation field operation test –shadowing profile
Test overview Communication protocol test under propagation simulation field test			
Test conditions <ul style="list-style-type: none"> <li>• Test Application Program: Basic Test Program (Refer to Annex 2)</li> <li>• Basic Parameters: Parameters as per section 2.3.2.</li> <li>• Propagation profile: 8</li> <li>• Communication sequence: The sequence specified in section 2.3.2.5</li> </ul>			
Test procedure <ol style="list-style-type: none"> <li>1. Conducts the communication sequence between the test equipment and the OBE.</li> <li>2. Repeats 100 sequences</li> </ol>			
Confirmation items <ul style="list-style-type: none"> <li>• The communication sequence is conducted in conformance with specification.</li> </ul>			

Test number	2-2-3-1	Items	Propagation simulation field operation High speed Propagation simulation field operation test – ideal profile – maximum input power at an OBE
Test overview Communication protocol test under propagation simulation field test			
Test conditions <ul style="list-style-type: none"> <li>• Test Application Program: Basic Test Program (Refer to Annex 2)</li> <li>• Basic Parameters: Parameters as per section 2.3.2.</li> <li>• Propagation profile: 9-1</li> <li>• Communication sequence: The sequence specified in section 2.3.2.5</li> </ul>			
Test procedure <ol style="list-style-type: none"> <li>1. Conducts the communication sequence between the test equipment and the OBE.</li> <li>2. Repeats 100 sequences</li> </ol>			
Confirmation items <ul style="list-style-type: none"> <li>• The communication sequence is conducted in conformance with specification.</li> </ul>			

Test number	2-2-3-2	Items	Propagation simulation field operation High speed Propagation simulation field operation test – ideal profile – minimum input power at an OBE
Test overview Communication protocol test under propagation simulation field test			
Test conditions <ul style="list-style-type: none"> <li>• Test Application Program: Basic Test Program (Refer to Annex 2)</li> <li>• Basic Parameters: Parameters as per section 2.3.2.</li> <li>• Propagation profile: 9-2</li> <li>• Communication sequence: The sequence specified in section 2.3.2.5</li> </ul>			
Test procedure <ol style="list-style-type: none"> <li>1. Conducts the communication sequence between the test equipment and the OBE.</li> <li>2. Repeats 100 sequences</li> </ol>			
Confirmation items <ul style="list-style-type: none"> <li>• The communication sequence is conducted in conformance with specification.</li> </ul>			

Test number	2-2-3-3	Items	Propagation simulation field operation High speed Propagation simulation field operation test – practical profile A
Test overview Communication protocol test under propagation simulation field test			
Test conditions <ul style="list-style-type: none"> <li>• Test Application Program: Basic Test Program (Refer to Annex 2)</li> <li>• Basic Parameters: Parameters as per section 2.3.2.</li> <li>• Propagation profile: : 10-1</li> <li>• Communication sequence: The sequence specified in section 2.3.2.5</li> </ul>			
Test procedure <ol style="list-style-type: none"> <li>1. Conducts the communication sequence between the test equipment and the OBE.</li> <li>2. Repeats 100 sequences</li> </ol>			
Confirmation items <ul style="list-style-type: none"> <li>• The communication sequence is conducted in conformance with specification.</li> </ul>			

Test number	2-2-3-4	Items	Propagation simulation field operation High speed Propagation simulation field operation test – practical profile B
Test overview Communication protocol test under propagation simulation field test			
Test conditions <ul style="list-style-type: none"> <li>• Test Application Program: Basic Test Program (Refer to Annex 2)</li> <li>• Basic Parameters: Parameters as per section 2.3.2.</li> <li>• Propagation profile: 10-2</li> <li>• Communication sequence: The sequence specified in section 2.3.2.5</li> </ul>			
Test procedure <ol style="list-style-type: none"> <li>1. Conducts the communication sequence between the test equipment and the OBE.</li> <li>2. Repeats 100 sequences</li> </ol>			
Confirmation items <ul style="list-style-type: none"> <li>• The communication sequence is conducted in conformance with specification.</li> </ul>			

Test number	2-2-3-5	Items	Propagation simulation field operation High speed Propagation simulation field operation test – adjacent lane passing profile
Test overview Communication protocol test under propagation simulation field test			
Test conditions <ul style="list-style-type: none"> <li>• Test Application Program: Basic Test Program (Refer to Annex 2)</li> <li>• Basic Parameters: Parameters as per section 2.3.2</li> <li>• Propagation profile: 11</li> <li>• Communication sequence: The sequence specified in section 2.3.2.5</li> </ul>			
Test procedure <ol style="list-style-type: none"> <li>1. Transmits FCMC from the TE</li> <li>2. Repeats 100 sequences</li> </ol>			
Confirmation items <ul style="list-style-type: none"> <li>• The DUT (OBE) does not transmit any ACTC.</li> </ul>			

Test number	2-2-3-6	Items	Propagation simulation field operation High speed Propagation simulation field operation test – shadowing profile
Test overview Communication protocol test under propagation simulation field test			
Test conditions <ul style="list-style-type: none"> <li>• Test Application Program: Basic Test Program (Refer to Annex 2)</li> <li>• Basic Parameters: Parameters as per section 2.3.2.</li> <li>• Propagation profile: 12</li> <li>• Communication sequence: The sequence specified in section 2.3.2.5</li> </ul>			
Test procedure <ol style="list-style-type: none"> <li>1. Conducts the communication sequence between the test equipment and the OBE.</li> <li>2. Repeats 100 sequences</li> </ol>			
Confirmation items <ul style="list-style-type: none"> <li>• The communication sequence is conducted in conformance with specification.</li> </ul>			

### Chapter 3 Application Interface Conformance Confirmation Test

#### 3.1 Scope

This application Interface Conformance Confirmation Test is for the verification of that the DUT (OBE) is conformance with the specified application interface with test application system. The DUT (OBE) should be certificated of DSRC conformance tests in Chapter 2 in advance of this test.

#### 3.2 Test configuration

Test configuration is as illustrated in Fig 3.1.

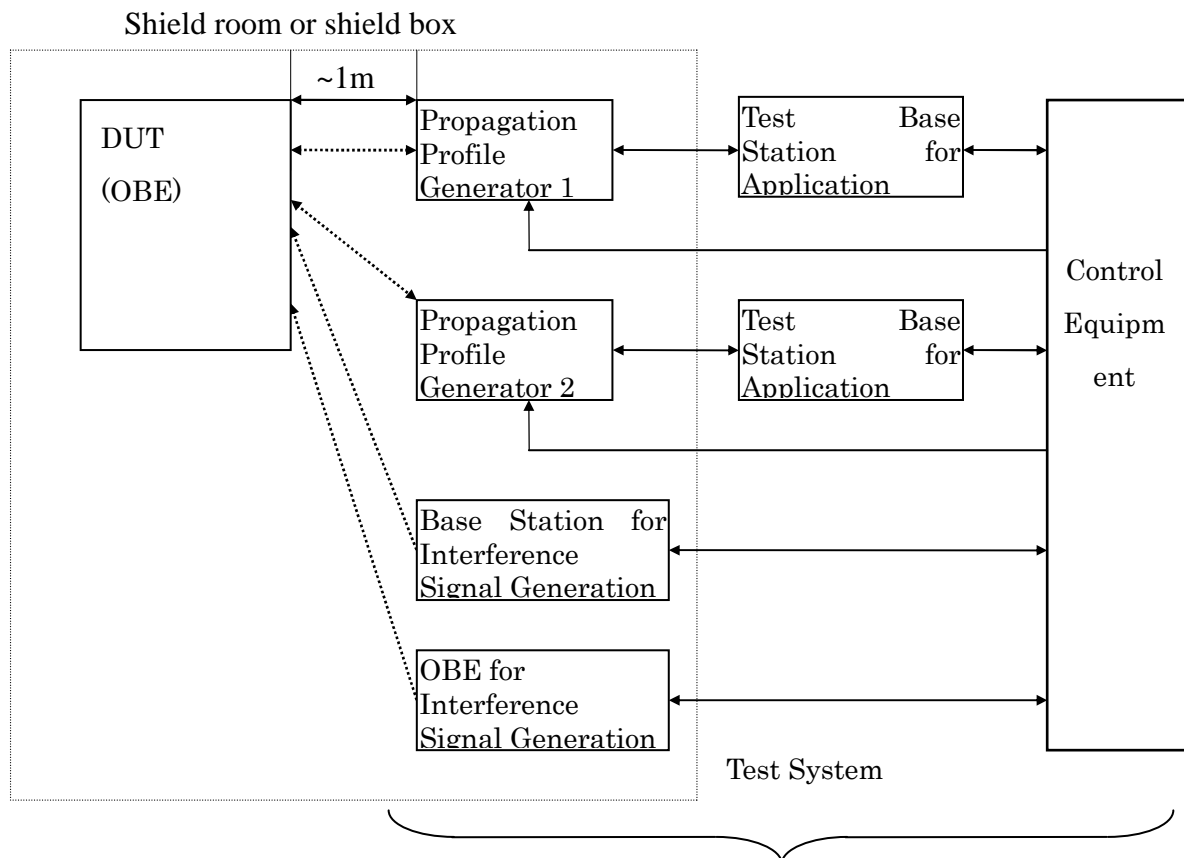

Fig. 3.1 The configuration example of the application interface conformance confirmation test

### 3.3 Out line of the application interface conformance confirmation test

The test should adopt the DUT (OBE) conducted the DSRC conformance confirmation test in chapter 2 in advance.

This confirmation test is categorized as the Electronic Toll Collection System (ETC) interface conformance confirmation test for the ETC OBE and other application interface conformance confirmation test for other application system OBE (non-ETC OBE).

#### 3.3.1 ETC interface conformance confirmation test for the ETC OBE

The TE should adopt the DUT (ETC OBE) conducted of the DSRC conformance confirmation test in chapter 2 and the compatibility conformance confirmation test between ARIB STD-T55 and ARIB STD-T75 in Annex 5 in advance. However, test items in chapter 2 shall be adopted as marked M (mandatory) and O (Optional) items of from table annex A4.1 through table annex A4.4 in Annex 4.

#### 3.3.2 Application interface conformance confirmation test for the non-ETC OBE

The TE should adopt the DUT (non-ETC OBE) conducted the DSRC conformance confirmation tests in chapter 2 in advance. However, test items in chapter 2 shall be adopted as marked M (mandatory) items of from table A4.1 through table A4.4 in Annex 4

### 3.4 Test items and Test conditions

#### 3.4.1 ETC OBE

##### 3.4.1.1 Tests for ETC application functions

The DUT (ETC OBE) shall adopt test items that are specified in section 4.3, "the test items and procedures for the ETC application interoperability conformance test", of the reference documents to the ETC application interoperability conformance confirmation tests issued by ORSE (Organization for Road System Enhancement: <http://www.orse.or.jp/>) and/or other authorities related to ETC operators.

##### 3.4.1.2 Tests for the external interface function

Test items and procedures for the DUT (ETC OBE), which has external interface, shall be adopted as specified in section 3.5.

#### 3.4.1.3 Tests for other functions

Test items for other functions, else ETC functions, of the DUT (ETC OBE) are not specified in this technical report.

#### 3.4.2 non-ETC OBE

##### 3.4.2.1 Tests for the external interface function

Test items and procedures for the DUT (non-ETC OBE), which has external interface, shall be adopted as specified in section 3.5.

##### 3.4.2.2 Tests for other functions, else the external interface function

Test items for other functions of the DUT (ETC OBE) are not specified in this technical report.

#### 3.5 Tests for the external interface function

To be described.

##### 3.5.1 Test items and procedures

To be described.

Empty page

## **Annex 1 Basic Concept Regarding the DSRC Test Procedure**

### **1. Introduction**

ARIB STD-T75 prescribes the standards for each layer (physical layer, data link layer, and application layer) in the Dedicated Short-Range Communication (DSRC) used by Electronic Toll Collection (ETC). This technical document prescribes the test procedure for verifying the compatibility of mobile stations (OBE) that contain DSRC functions.

In addition, this technical document prescribes testing procedures for analyzing and identifying causes of incompatibility.

In particular, the first half of the technical document (Chapter 2) covers all devices containing DSRC, and not just those containing specific applications. This is possible because DSRC does not apply to just a single application but is suitable for multiple types of applications and multiple applications.

This annex covers the basic concepts for a testing procedure that does not just apply to specific applications.

A testing procedure based on this type of concept provides a general method for certifying the compatibility of all devices that contain DSRC and, therefore, will have a wide range of application.

### **2. Scope of Test**

Generally, as shown in Fig. A1.2.1, devices containing DSRC consist of the DSRC part, which are configured of the L1, L2 and L7, the application part, and the API (application interface) between these two parts.

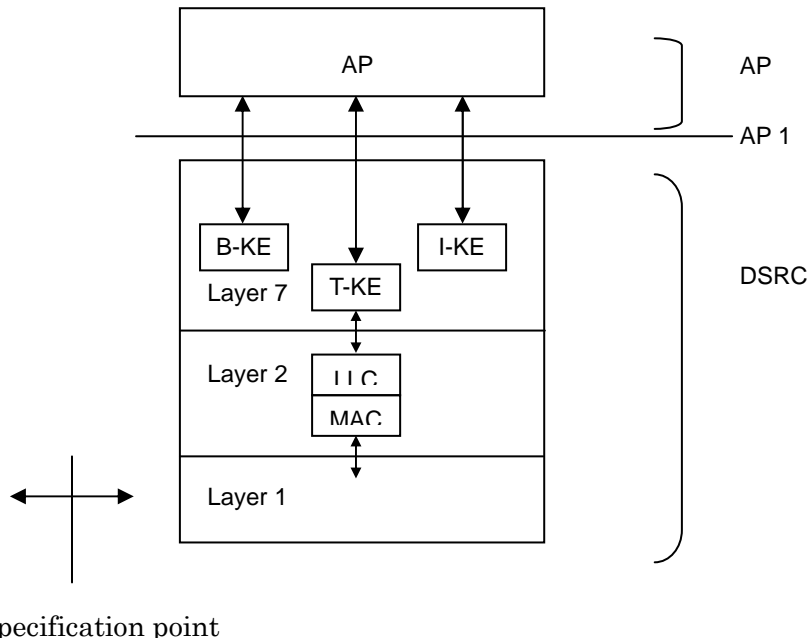

Fig. A1.2.1 DSRC Device Configuration

Because our objective is to verify the compatibility of the DSRC part regardless of the application, we only need to describe the testing procedure for the API and space specification points.

The lower bordered area in Fig A1.2.2 shows the scope of the testing procedure prescribed in this technical document. Therefore, the DSRC test procedure only needs to prescribe the operation confirmation items for the base station (RSU) API, mobile station (OBE) API, and the space specification points between the RSU and the OBE as well as the provisions for the environment, equipment internal settings, and test signals required to verify the same.

But we have encountered a great difficulty. That difficulty is that the API have been made application specific with most devices containing DSRC containing only an API the relies on a specific application in order to lower costs and furthermore it is likely that the corresponding DSRC part only contain the functions necessary to use the specific application. And so it is meaningless to remove the application from such devices and conduct testing using a test application.

For this reason it is nearly impossible to verify the compatibility of the DSRC part irrespective of the application. But we have implemented the following measures to overcome this difficulty.

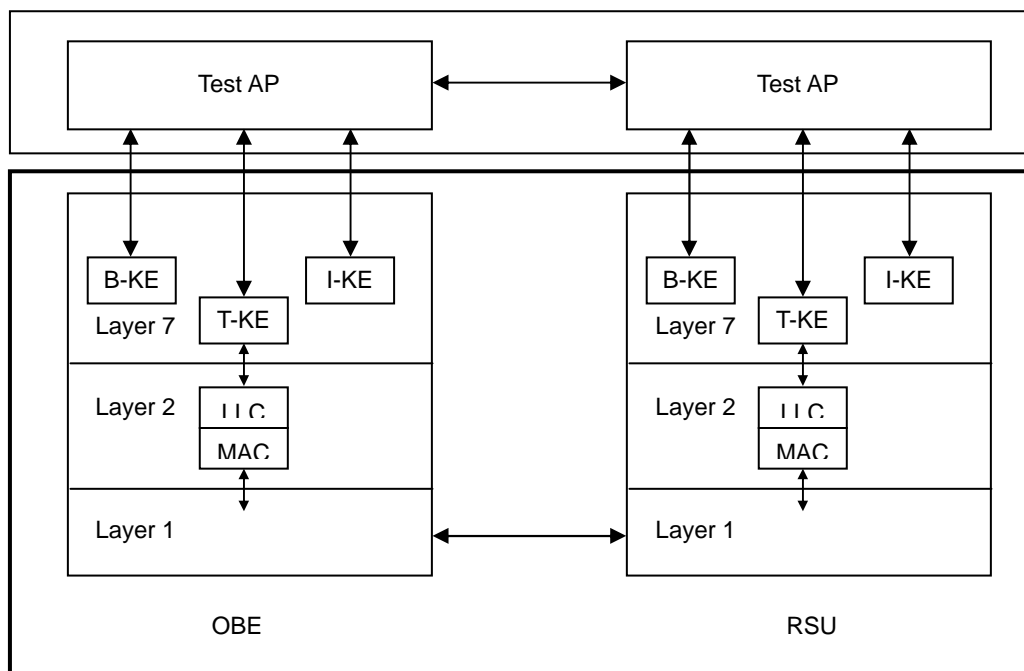

Fig. A1.2.2 Scope of Testing Procedure

<<Measures>>

- 1) The DSRC part is divided as follows.

**Basic Section:** This section is selected to have only the minimum required elements for DSRC operation. The variable parameters are fixed. Contains only the areas necessary for operation.

**Application Section:** The area required by the application.

- 2) The DSRC testing procedure is only prescribed for the Basic Section.
- 3) A test program is defined to test the Basic Section.
- 4) It is recommended or required that all DSRC devices contain the test program.

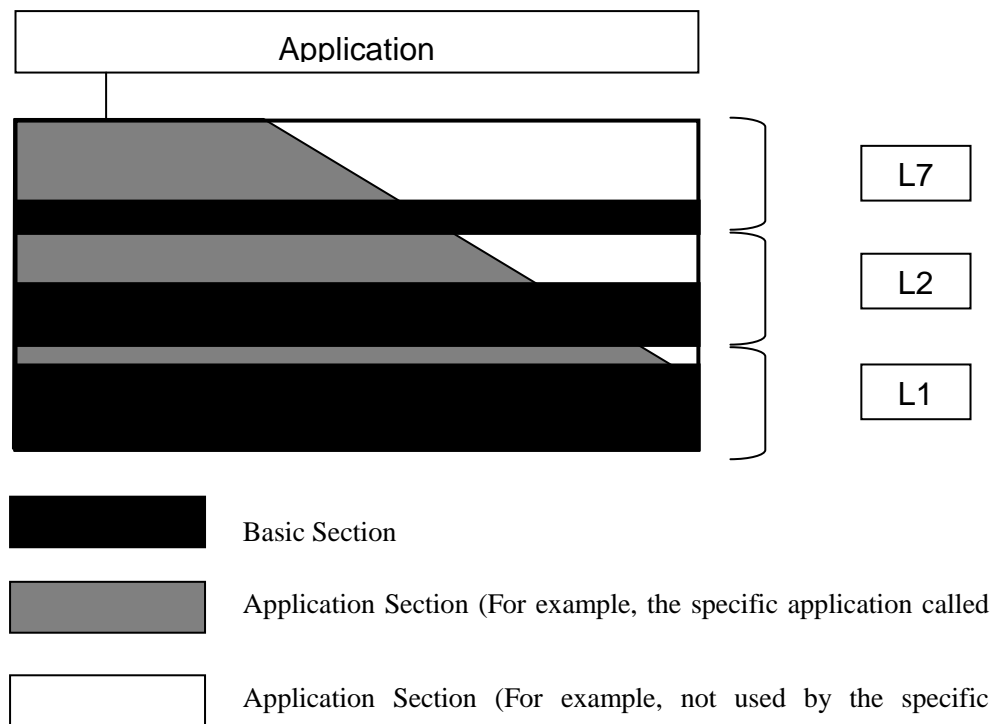

Fig. A1.2.3 DSRC part

When using measures like those above, the scope of application of this testing procedure is as shown in Fig. A1.2.4.

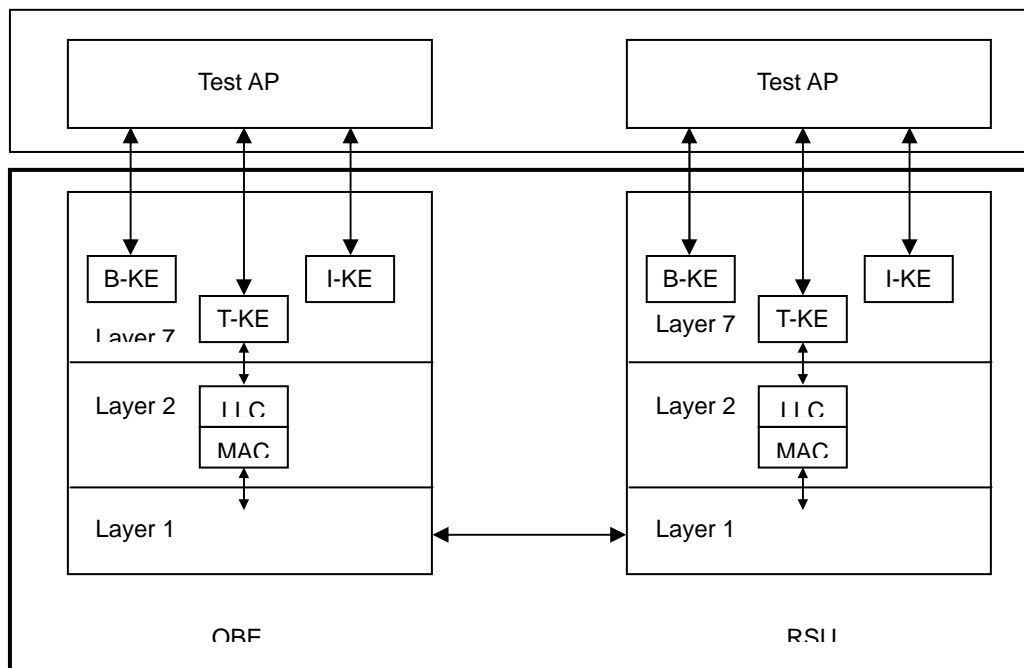

Fig. A1.2.4 Scope of application of this testing procedure

The concerns when using measures such as those above are as follows.

1) Suitability of the test scope (Suitability of testing only the basic section)

The Basic Section contains nearly all of L1 and nearly all of the fixed L2, and for L7 contains the basic items, such as the start and end procedures. Therefore, the Basic Section test can accurately assess nearly all of the representative items of the DSRC part.

2) The Application Section is tested when the application is loaded, but for the above reasons it is not large and can be tested with little burden.

3) Regarding the loading of the test program, consideration must be taken so that there is little burden on the OBE, but because it is limited to the Basic Section, the burden is expected to be light.

The above method makes it possible to achieve our objective of verifying the compatibility of the DSRC part irrespective of the application.

### 3. Mutual Relationship Between Tests

This section correlates the relationship between the test procedure prescribed in this standard and test procedures prescribed elsewhere in terms of the testing of devices containing DSRC.

For example, the mutual relationship with tests from other standards is shown in Fig. A1.3.1. Here, the DSRC Interface tests are conducted after the Application Interface tests, but when the application has functions for controlling the DSRC via the API, then it is very difficult to verify these kinds of functions during the Application Interface tests.

Therefore, when conducting this procedure the Application Interface tests and DSRC Interface tests are conducted concurrently and so if a problem is found it could be very difficult to analyze the problem.

The mutual relationship between the tests in this technical document is shown in Fig. A1.3.2.

The Application Interface tests and DSRC Interface tests are conducted after the DSRC Basic Section tests are completed, but because there exists a DSRC Basic Section tests stage it is very easy to analyze problems and quickly resolve the trouble.

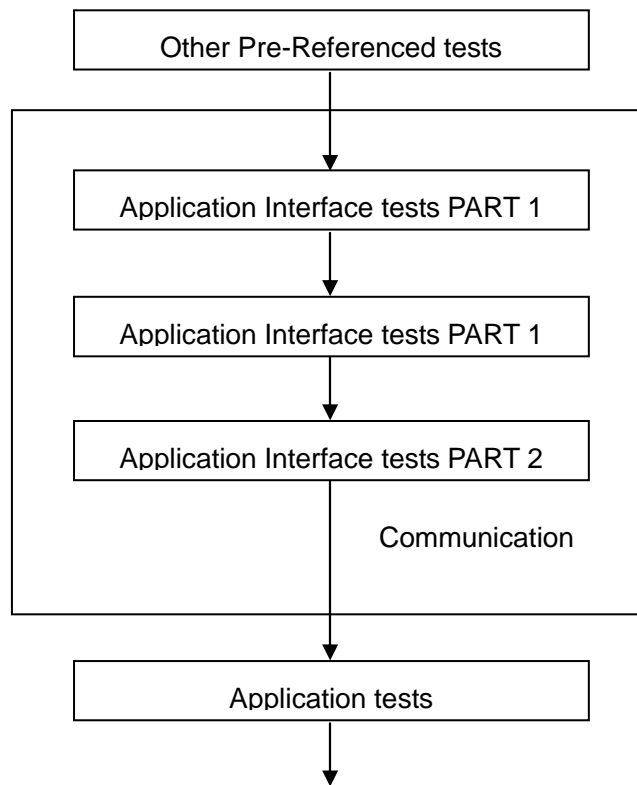

Fig. A1.3.1 Mutual relationship of test procedures

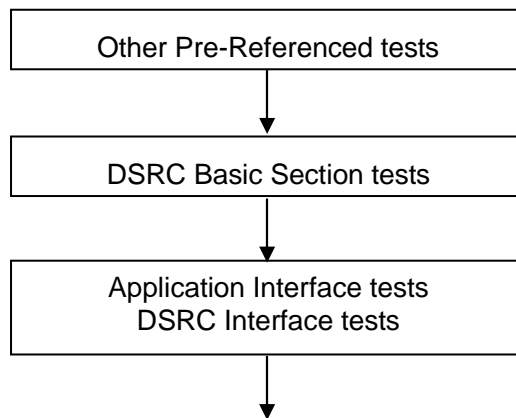

Fig. A1.3.2 Mutual relationship of test procedures in this technical document

Empty page

## Annex 2 Test program specifications for OBE

### 1. Configuration of Test program specification for OBE

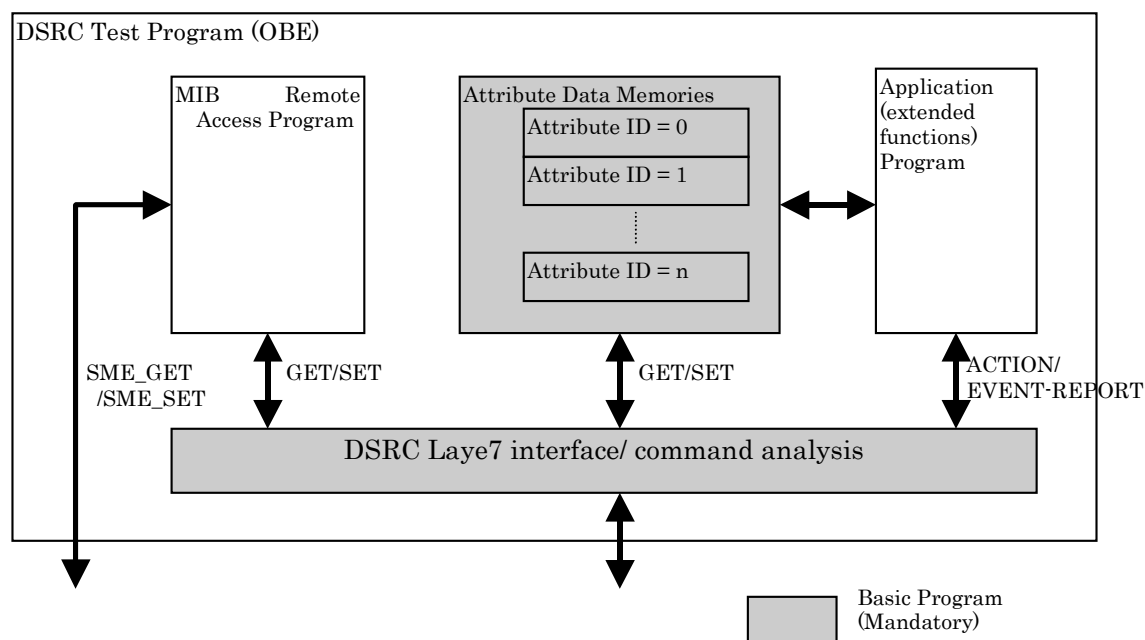

Fig. A2.1. Configuration of Test program specification for OBE

Configuration of Test program specification for OBE (DSRC Test Program for OBE) is shown in Fig. A2.1. The elements of test program are defined.

Broadcast function is the out scope of this test program. Furthermore, a simplified initialization procedure is to be described.

#### 1.1 Basic Test Program

The test program consists of the layer 7 interface / command analysis element and Attribute Data memories to write / read process for transmission data.

Access to data is performed using GET / SET primitives defined in Layer 7.

Attribute ID and Attribute for data are defined. Depending on communication profile, data area is specified. (Refer to Chapter 7 of this annex).

The data area (attribute data memory) is kept enough size, which enable to confirm fragmentation process according to communication profile.

#### 1.2 Application (function extension) program (Specific Application Test Program)

This confirms processing related to the ACTION / EVENT-REPORT primitives related to

## ARIB TR-T16

user defined area (ActionType/EventType).

The test functions are defined in the action confirmation.

This program is an option.

### 1.3 MIB Remote Access Program

This program writes new parameters in response to the test items from the respective TE.

The access to the MIB from the TE specifies the MIB variables at the attribute ID via the layer 7 GET / SET primitives. (Refer to Chapter 7 of this annex).

This program is an option.

## 2. Implementation method (Method for alternating the test mode)

Either of the following two procedures can be used.

A: Manually alternating to the test mode. (Only the test program is registered.)

B: Automatic start up from the TE (another application program is registered at the same time as the test program).

## 3. Test Program Identification Information

### 3.1 Test program combinations

A variety of test program combinations are possible depending on the existence of various option functions. The mobile station can suitably select the test program to be loaded, but this assumes that if there are separately specified required test items the corresponding functions are loaded.

### 3.2 Identification

The test program uses AID = 0 (system application) and uses element definition information for identification. However, combinations are not identified, so the TE using initial settings handles test program combinations that are loaded in the mobile station.

### 3.3 ContextMark (element definition information for identification)

Configuration of ContextMark (element definition information for identification) is as follows and SystemID identifies test program. Parameter is option and is not used in test program.

```
System-ContextMark ::= SEQUENCE{
    SystemID          systemid,          -- systemid = 1
```

```

        Parameter      OCTET STRINGOPTIONAL  -- empty
    }

    systemid ::= INTEGER{
        system           (0)                -- reserved for system
        testApplication (1)                -- test program
        Reserved for Future Use (2...127)
    }(0...127)

```

This element information (System-ContextMark) is contained in VST parameter. On this process, Parameter selects OCTET STRING type defined by the Container type.

### 3.4 Identification of OBE

Different test groups in OBE are used depending on communication profile as described in chapter 7 of this annex.

The DUT (OBE) notifies the communication profile in advance. It assumes that according to notified communication profile, the TE set Test Data Group on the test program and gets / identified the communication profile selected on DUT (OBE) (contained in VST) by the system management services.

## 4. Initialization Parameters

### 4.1 Layer 2-application service field (SC)

SC field of FCMC transmitted from the TE shall be set as below referring to above identified information definition. (Normal initialization)

Table A2.4.1 SC field of FCMC

Octet number	7	6	5	4	3	2	1
Data Name	Reserved	Reserved	AID (4)	AID (3)	AID (2)	AID (1)	IMI
Value	00H	00H	Note1	Note1	Note1	Note1	00H

(Note1) Octet field for AID (AID=0), which identifies Test program (Test Equipment) is depending on test items.

Table A2.4. SC field of LRI of ACTC

Bit number	8	7	6	5	4	3	2	1
Data Name	Application Identifier				PVI		IMI	Emergency
Value	(Note2)	(Note2)	(Note2)	(Note2)	(Note3)		0	0

(Note2) Storage bit fields (Application Identifier) for application identification results shall be set in conformance with ARIB STD-T75 procedures.

(Note3) Storage bit fields (PVI) for protocol identification results shall be set in conformance with ARIB STD-T75 procedures.

#### 4.2 Layer 7 BST/VST

The BST/VST that replaces the Layer 7 I-KE in the standard test procedure becomes as follows based on the above identification information definition.

Variable “empty” in following ASN.1 data structure is ordinary omitted, but it may not be omitted according test contents (items).

##### (1) BST

```

BST ::= SEQUENCE{
    RSU                BeaconID,
    time               Time,
    profile            Profile,
    mandApplications  ApplicationList,
    nonmandApplications ApplicationList OPTIONAL, -- empty
    profileList       SEQUENCE OF Profile        -- empty
}
    
```

```

ApplicationList ::= SEQUENCE(0..127,...) OF SEQUENCE{
    aid                DSRCApplicationEntityID, -- aid=0
    eid                Dsrc-EID                OPTIONAL, -- empty
    parameter         Container                OPTIONAL -- empty
}
    
```

##### (2) VST

```

VST ::= SEQUENCE {
    fill              BIT STRING (SIZE(4)),
    profile           Profile,
    applications      ApplicationList,
    obeConfiguration ObeConfiguration
}
    
```

```

ApplicationList ::= SEQUENCE(0..127,...) OF SEQUENCE{
    
```

```

aid          DSRCApplicationEntityID,          -- aid=0
eid          Dsrc-EID          OPTIONAL,        -- e.g. 5
parameter   Container          OPTIONAL        -- System-ContextMark
}
    
```

5. Initialization and data transmission

Fig. A2 5.1 shows a transaction example by a test program that uses the initialization parameters defined in Chapter 4 of this annex.

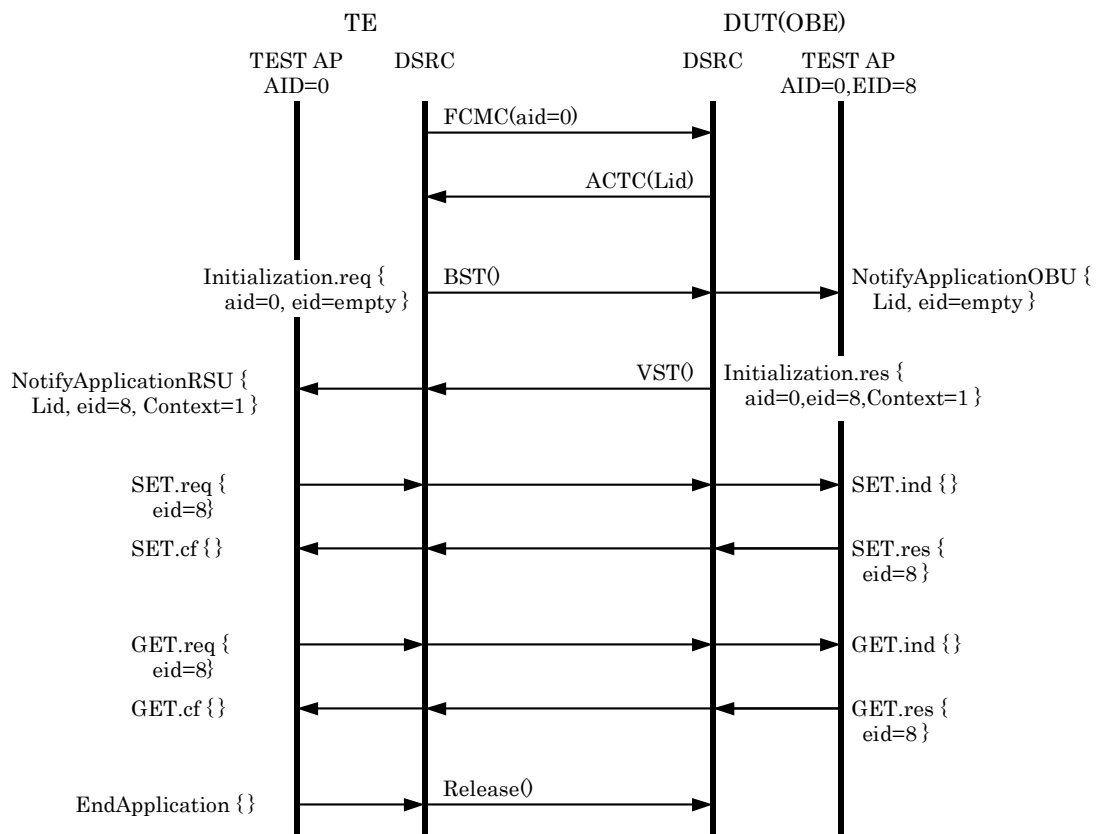

Fig. A2.5.1 Transaction example (Normal Initialization Procedure)

6. Application Interface

6.1 Interface classification

The test program uses the interface provided by layer 7 to communicate with the TE. Table A2 6.1 shows the interface used by the test program.

Table A2 6.1 the interface used by the test program

	Basic test program	Application (function extension) program	MIB remote access program
RegisterApplication OBU	✓		
DeregisterApplication	✓		
NotifyApplication OBU	✓		
EndApplication	✓		
GET	✓		✓
SET	✓		✓
ACTION		✓	
EVENT-REPORT		✓	
SME_GET			✓
SME_SET			✓

6.2 Interface format

The interface format provided by layer 7 is shown below. The parameters contained in [] can be omitted, and when omitted to a comment, the test program does not use some parameters.

(1) Application registration and deregistration primitives

```

RegisterApplicationOBU (
    AID,           // 0 (System)
    Priority,      // 0
    EID,          // Any numbers from 4 to 127
    [Profiles],   // the DUT (OBE) communication profile(s)
    [Parameter]   // System-ContextMark=1(test program)
)
DeregisterApplication (
    AID,           // 0 (System)
    [EID]         // Omitted
)
    
```

## (2) Communication initialization / termination primitive

```

NotifyApplicationOBU (
    Beacon,           // BeaconID
    Priority,         // Value created in the mobile station layer 7 (0)
    EID,             // empty
    LID,             // link address issued by the DUT (OBE) layer 7
    [EID]            // Omitted
)
EndApplication (
    EID,             // passing value with RegistrationApplicationOBU().
    LID,             // passing value with NotificationApplicationOBU().
    [Norm_end]       // Value that corresponds to the processing results when an
                    // extension program is included.
                    // Always set to normal end (1) when just the basic test
                    // program.
)

```

## (3) Data access primitives

```

GET.request (
    [IID],           // Omitted
    LID,
    EID,
    Chaining,
    [Access Credentials], // Omitted
    [AttributeIdList],   // Cannot be omitted
    FlowControl         // 2 (DL-UNITDATE.req with response request)
)
GET.indication (
    [IID],           // Omitted
    LID,
    EID,
    Chaining,
    [Access Credentials], // Omitted
    [AttributeIdList],   // Cannot be omitted
    FlowControl         // 3 (DL-UNITDATA.ind)
)

```

```

GET.response (
  [IID],           // Omitted
  LID,
  EID,
  Chaining,
  FlowControl      // 1 (DL-UNITDATA.req without response request)
  [AttributeList], // Cannot be omitted
  [Ret]           // Omitted
)
GET.confirm (
  [IID],           // Omitted
  LID,
  Chaining,
  [AttributeList], // Cannot be omitted
  [Ret]           // Omitted
)
SET.request (
  [IID],           // Omitted
  LID,
  EID,
  Chaining,
  [Access Credentials], // Omitted
  AttributeList,
  Mode,
  FlowControl      // Mode=0 : 1 (DL-UNITDATA.req without response request)
                  // Mode=1 : 2 (DL-UNITDATA.req without response request)
)
SET.indication (
  [IID],           // Omitted
  LID,
  Chaining,
  [Access Credentials], // Omitted
  AttributeList,
  Mode,
  FlowControl      // 3 (DL-UNITDATA.ind)
)

```

```

SET.response (
  [IID],           // Omitted
  LID,
  EID,
  Chaining,
  FlowControl      // 1 (DL-UNITDATA.req without response request)
  [Ret]           // Omitted
)
SET.confirm
  [IID],           // Omitted
  LID,
  Chaining,
  [Ret]           // Omitted
)
ACTION.request (
  [IID],           // Omitted
  LID,
  EID,
  Chaining,
  Action Type,
  [Access Credentials], // Omitted
  [Action Parameter],
  Mode,
  FlowControl      // Mode=0 : 1 (DL-UNITDATA.req without response request)
                  // Mode=1 : 2 (DL-UNITDATA.req without response request)
)
ACTION.indication (
  [IID],           // Omitted
  LID,
  Chaining,
  Action Type,
  [Access Credentials], // Omitted
  [Action Parameter],
  Mode,
  FlowControl      // 3 (DL-UNITDATA.ind)
)

```

```

ACTION.response (
  [IID],           // Omitted
  LID,
  EID,
  Chaining,
  FlowControl      // 1 (DL-UNITDATA.req without response request)
  [Response Parameter],
  [Ret]
)
SET.confirm
  [IID],           // Omitted
  LID,
  Chaining,
  [Response Parameter],
  [Ret]
)
EVENT-REPORT.request (
  [IID],           // Omitted
  LID,
  EID,
  Chaining,
  Event Type,
  [Access Credentials], // Omitted
  [Event Parameter],
  Mode,
  FlowControl      // Mode=0 : 1 (DL-UNITDATA.req without response request)
                  // Mode=1 : 2 (DL-UNITDATA.req without response request)
)
EVENT-REPORT.indication (
  [IID],           // Omitted
  LID,
  Chaining,
  Event Type,
  [Access Credentials], // Omitted
  [Event Parameter],
  Mode,
  FlowControl      // 3 (DL-UNITDATA.ind)
)

```

```

EVENT-REPORT.response (
  [IID],           // Omitted
  LID,
  EID,
  Chaining,
  FlowControl,    // 1 (DL-UNITDATA.req without response request)
)
EVENT-REPORT.confirm
  [IID],           // Omitted
  LID,
  Chaining,
  [Ret]
)

```

## 7. Test Attributes

### 7.1 Test Attributes specification

The attributes used by the test program are comprised of a test data group and a MIB parameter group. The test program shall have the data area of the test data group. The MIB parameter group uses items that have been prepared by the DSRC protocol processing.

Table A2.7.1 TEST Attributes

Attribute ID	Attribute	Octet length	Data Group	Remarks
0	TestData1	30	Test Data	
1	TestData2	14		
2	TestData3	6		
3	TestData4	6		
4	PHY_TEST	1	MIB Parameter	
5	OMAC_TEST	3		
6	TestData5	[90] (Note1)	Test Data	
7	TestData6	[120] (Note1)		

(Note1) Tentative length. This length might be change in revision of this technical report.

Table A2.7.2 Test Data Group Contents

Attribute	Data element	Description	Type	Size	Remarks
TestData1	TestData1	For test data storage	OCTET STRING	30oct	Can be overwritten and read
TestData2	TestData2	For test data storage	OCTET STRING	14oct	Can be overwritten and read
TestData3	TestData3	For test data storage	OCTET STRING	6oct	Can be overwritten and read
TestData4	TestData4	For test data storage	OCTET STRING	6oct	Can be overwritten and read
TestData5	TestData5	For test data storage	OCTET STRING	[90] oct (Note1)	Can be overwritten and read
TestData6	TestData6	For test data storage	OCTET STRING	[120] oct (Note1)	Can be overwritten and read

(Note1) Tentative length. This length might be change in revision of this technical report.

The physical arrangement of the MIB parameter group data elements is shown in Table Annex 2.7.3. The bit weighting is the MSB in the top centerline of the table MIB Parameter.

Table A2.7.3 MIB Parameter Group Contents

Attribute	Data element	Description	Type	Size	Remarks
PHY_TEST	Fill	For boundary adjustment	BIT STRING	1bit	
	CWMode	CW transmission mode selection	BIT STRING	2bit	Overwrite only
	PNSendMode	PN pattern transmission mode selection	BIT STRING	2bit	Overwrite only
	SendMode	Test mode transmission pattern selection	BIT STRING	2bit	Overwrite only
	CarrierOFF	Carrier wave mask	BIT STRING	1bit	Overwrite only
OMAC_TEST	Fill	For boundary adjustment	BIT STRING	5bit	
	ACK_MASK	ACKC transmission processing mask variable	BOOLEAN	1bit	Overwrite only
	RETRY_MASK	Retry processing mask variable	BOOLEAN	1bit	Overwrite only
	CRC_MASK	CRC investigation mask variable	BOOLEAN	1bit	Overwrite only
	CRC_ERR	CRC investigation error count	INTEGER	2oct	Overwrite only

7.2 Implementation scope of data group for communication profile

According to the DUT (OBE) communication profile(s), the test program on the DUT (OBE) shall have the data area of the test data group as shown in Table A2.7.4.

Table A2.7.4 Implementation scope of data group for communication profile

Attribute ID	Communication profile			
	9	10	11	12
0	✓	✓	✓	✓
1	✓	✓	✓	✓
2	✓	✓	✓	✓
3	✓	✓	✓	✓
6			✓	✓
7			✓	✓

(Note) Attribute ID, 4 and 5, is belonging to MIB Parameter group. Therefore, the remote access program (option) uses these Attribute IDs.

## 8. Basic test program

### 8.1 Data area initialization

The basic test program does not initialize the data area of the test data group. The test data group data area initialization is conducted when required by the TE that uses a SET primitive

### 8.2 Connection timer

The basic test program sets a connection timer as a reception opportunity for the NotificationApplicationOBU.

When the time required by the connection timer is calculated, the basic test program issues an EndApplication and begins communication.

The Norm\_end parameter passed with EndApplication is 1 (normal end).

### 8.3 Note for AttributeIdList and AttributeList

The format definition of the Attribute IdList and AttributeList passé with the GET/SET primitives and an example of the corresponding coding are shown below. The test program directly treats the coding data as shown in Fig. A2 8.1 and Fig. A2 8.2.

In addition, the TAG information and length information added in accompaniment with the coding remain unchanged and a storage area for storing this data is arranged.

Outline of the data access process using GET / SET primitives is shown in Fig A2.8.3、 Fig A2.8.4.

#### ASN.1 description

```
AttributeIdList ::= SEQUENCE (0..127,...) OF INTEGER (0..127,...)
AttributeList ::= SEQUENCE (0..127,...) OF Attributes
Attributes ::= SEQUENCE {
    attributeId      INTEGER (0..127,...)
    attributeValue   Container          -- Choice OCTET STRING
}

```

#### Coding example of AttributeIdList

```
AtrIdList  AttributeIdList ::= { 1, 3 }
```

8 (MSB)	7	6	5	4	3	2	1 (LSB)
0	AttributeId Numbers (2)						
0	attributeId (1)						
0	attributeId (3)						

Fig. A2.8.1 Coding of AtrIdList

Coding example of AttributeList

AtrList AttributeList ::= { Atr1, Atr3 }

Atr1 Attributes ::= {  
 attributeId 1,  
 attributeValue OCTET STRING:  
 00112233445566778899AABBCCDD'H  
 }

Atr3 Attributes ::= {  
 attributeId 3,  
 attributeValue OCTET STRING: '0123456789AB'H  
 }

8 (MSB)	7	6	5	4	3	2	1 (LSB)
0	AttributesNumbers (2)						
0	attributeId (1)						
0	Tag (OCTET STRING = 2)						
0	Length (14)						
00H							
11H							
22H							
:							
CCH							
DDH							
0	attributeId (3)						
0	Tag (OCTET STRING = 2)						
0	Length (6)						
01H							
23H							
:							
ABH							

Fig A2.8.2 Coding of AtrList

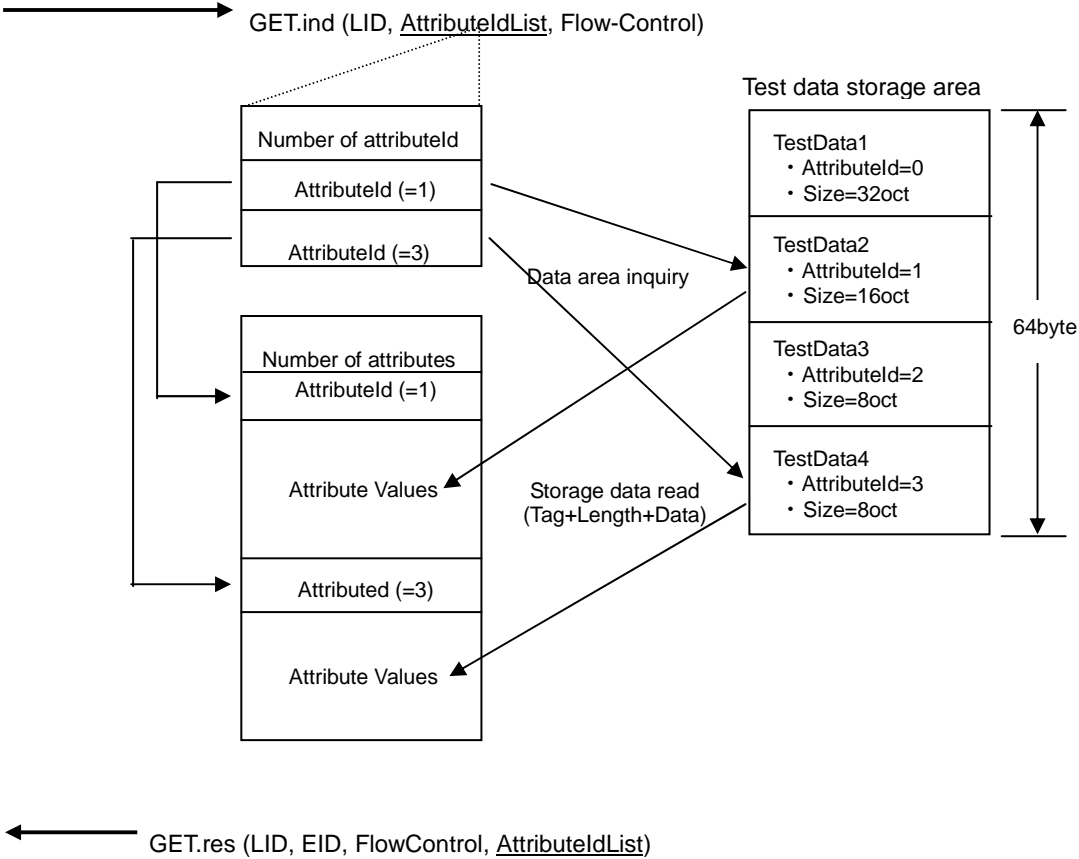

Fig. A2.8.3 Test data read example (the communication profile is 9.)

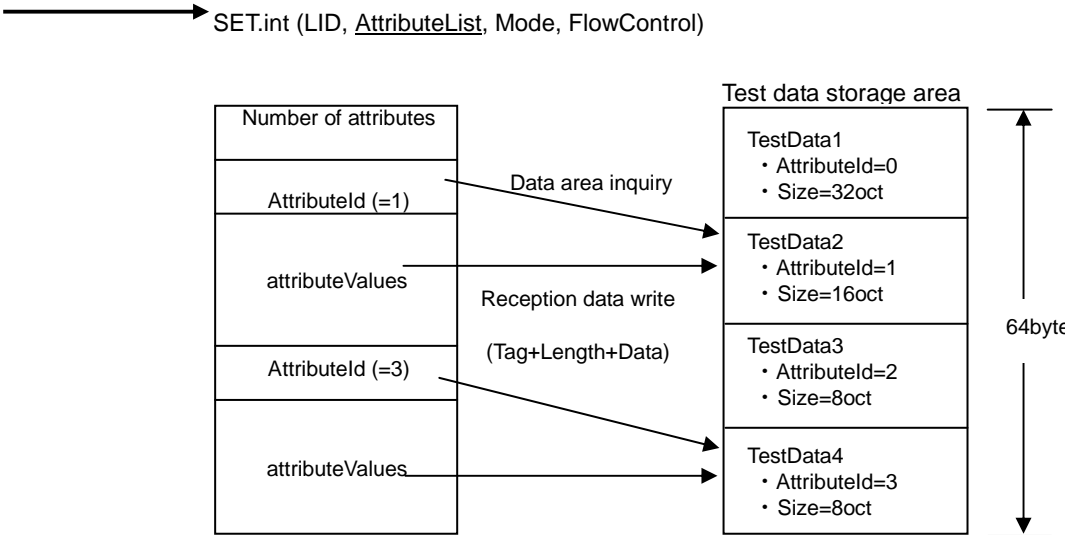

Fig. A2.8.4 Test data write example (the communication profile is 9.)

## 9. Application (Function Extension) Program

Application (Function Extension) Program is to be described.

## 10. Remote Access Program

The access to the MIB of the DUT (OBE) from the TE is made using the GET primitive, SET primitive. The MIB variable specification is performed using the Attribute Id prescribed in Chapter 7 of this annex, and the value is passed with the attribute.

The access to the MIB of the DUT (OBE) from the test program is made using the interface prescribed by the SME\_GET primitive, SME\_SET primitive, but because this processing is completed internally, there are no loading restrictions.

The operation of the DUT (OBE) in response to the values set in the MIB parameter group data elements is specified as below.

### 10.1 PHY\_TEST

#### (1) CWMode

This is the parameter that is used to set the continuous wave (CW) transmission mode. The prescribed operation is to begin using the setting of the value as an opportunity.

CWMode = 0: the normal status. (default value)

CWMode = 1: continuous wave transmission

CWMode = 2: not used

CWMode = 3: not used

#### (2) PNSendMode

This is the parameter that sets the PN pattern transmission mode. The prescribed operation is to begin using the setting of the value as an opportunity. The PN pattern uses the formation polynomial prescribed by ARIB STD-T75.

PNSendMode = 0: the normal status. (default value)

PNSendMode = 1: split phase coding using PN pattern

PNSendMode = 2: NRZ coding using PN pattern

PNSendMode = 3: not used

## (3) SendMode

SendMode = 0 the normal status. (default value)

SendMode =1: split phase coding using continuous [1] pattern

SendMode =2: split phase coding using continuous [10] pattern

SendMode = 3: NRZ coding using PN pattern

## (4) CarrierOFF

This is the control parameter for prohibiting carrier wave transmission. The prescribed operation is to begin using the setting of the value as an opportunity.

CarrierOFF = 0: the normal status. (default value)

CarrierOFF =1: prohibits carrier wave transmission

## 10.2 OMAC\_TEST(option)

## (1) ACK\_MASK

This is the parameter that controls the ACKC transmission processing. The prescribed operation is to begin using the setting of the value as an opportunity.

ACK\_MASK = 0: the normal status. (default value)

ACK\_MASK= 1:prohibits ACKC transmission. However, the normal processing, such as CRC verification, remain valid.

## (2) RETRY\_MASK

This is the parameter that controls retry processing. The prescribed operation is to begin using the setting of the value as an opportunity.

RETRY\_MASK = 0: the normal status. (default value)

RETRY\_MASK = 1: prohibits retry processing when the retry conditions are satisfied.

## (3) CRC\_MASK

This is the parameter that controls CRC investigation. The prescribed operation is to begin using the setting of the value as an opportunity.

CRC\_MASK = 0: the normal status. (default value)

CRC\_MASK = 1:prohibits CRC investigation.

## (4) CRC\_ERR

This is the parameter that keeps track of the CRC verification error count. This parameter conducts initialization when a MLME\_ASSOCIATE request is issued and adds one to the

## **ARIB TR-T16**

count each time an error is detected by the CRC verification. When the count results overflow this is set to a -1 and counting thereafter is prohibited.

The MDC is subject to the CRC calculation.

### 10.3 End processing

When the test program issues EndApplication and begins communicating, default values are used for all PHY\_TEST and OMAC\_TEST setting values.

11 SDL Diagram (Informative Reference)

The following symbols and abbreviations are used in this document. The complete information regarding the symbols, respective meaning, and usage method is contained in the ITU-T Z Series recommendations.

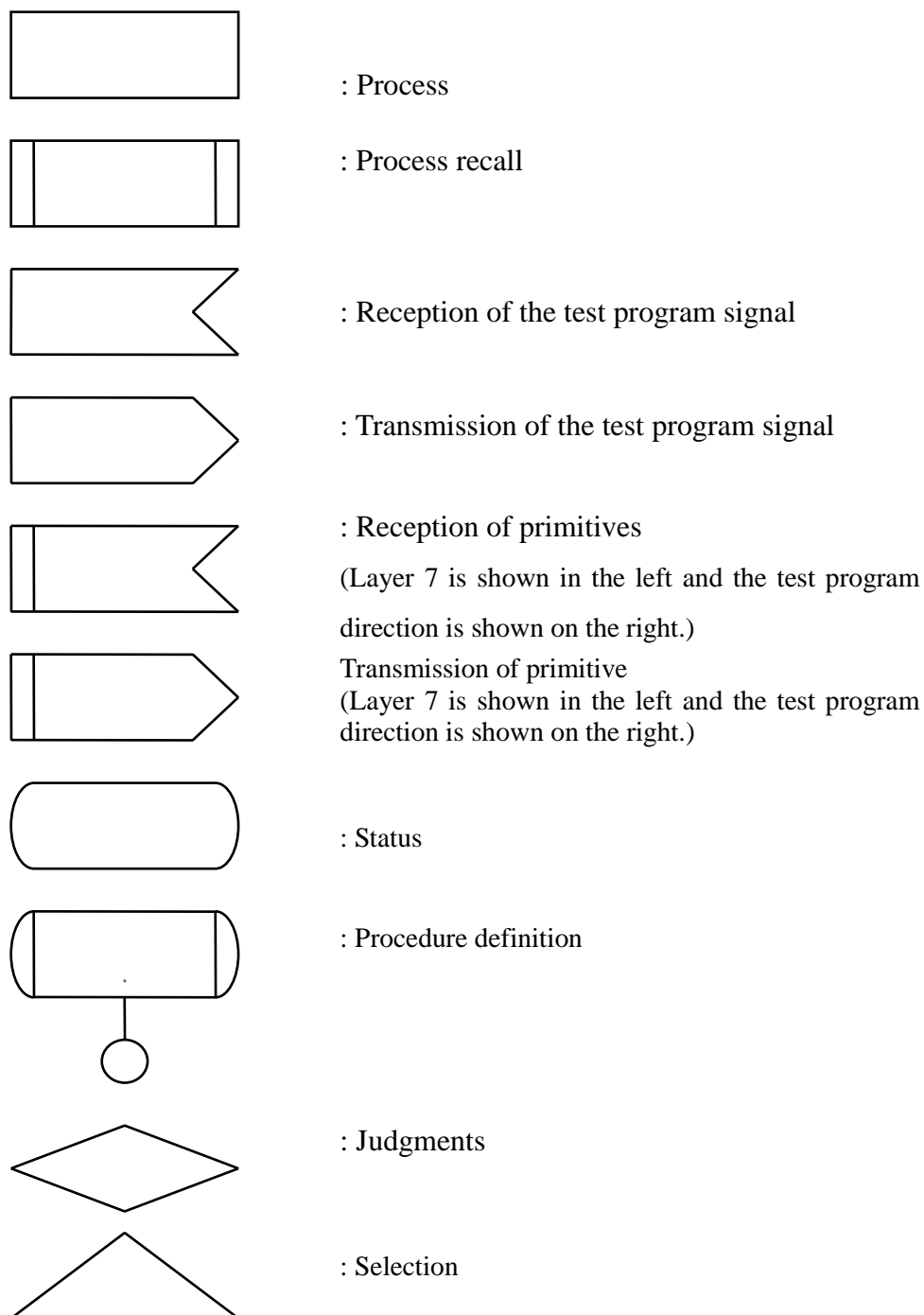

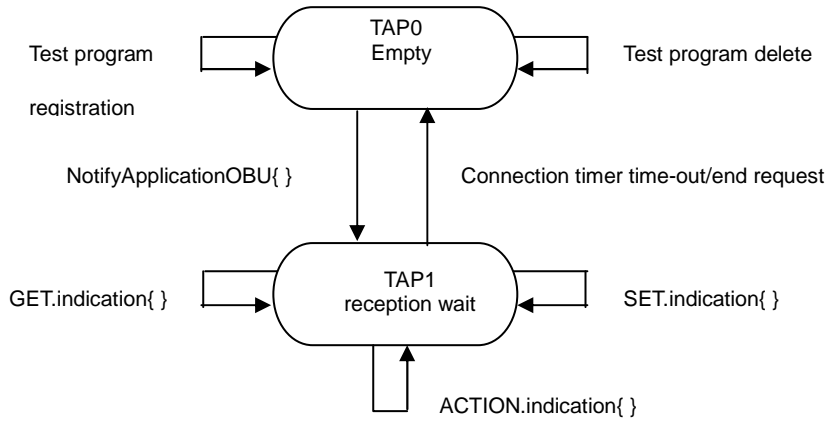
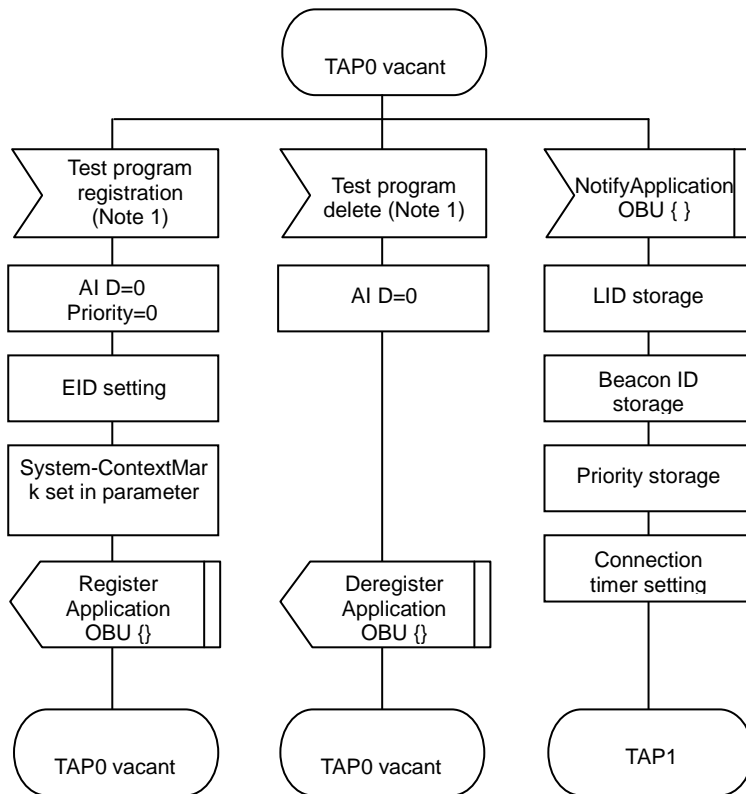
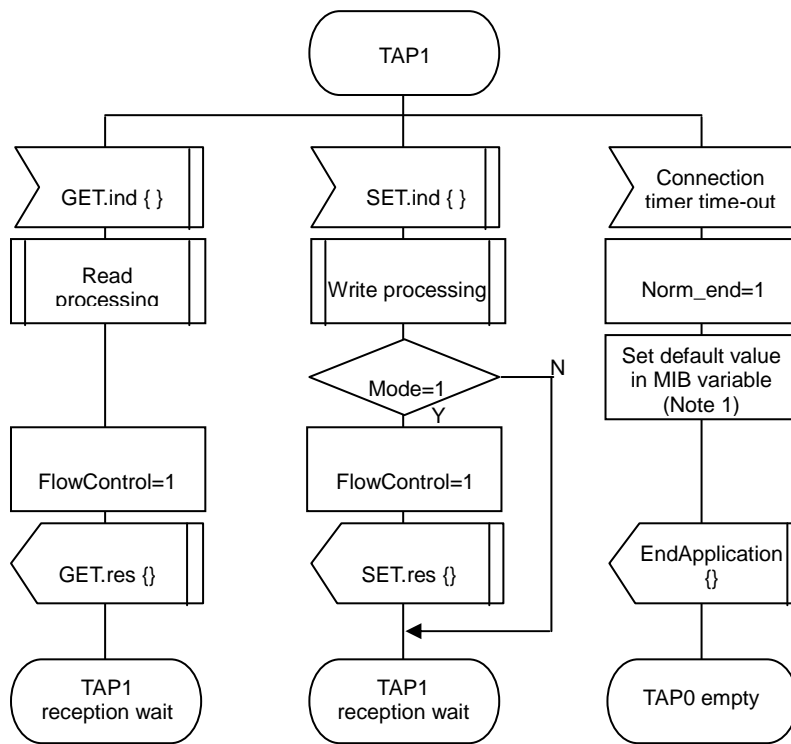

Fig A2.11.1 State diagram of the test program



Note1: No execution opportunity in particular is prescribed for test program registration/deletion.

Fig A2.11.2 SDL for test program



Note1: Processed when the MIB remote access program is executed

Fig A2.11.3 SDL for test program

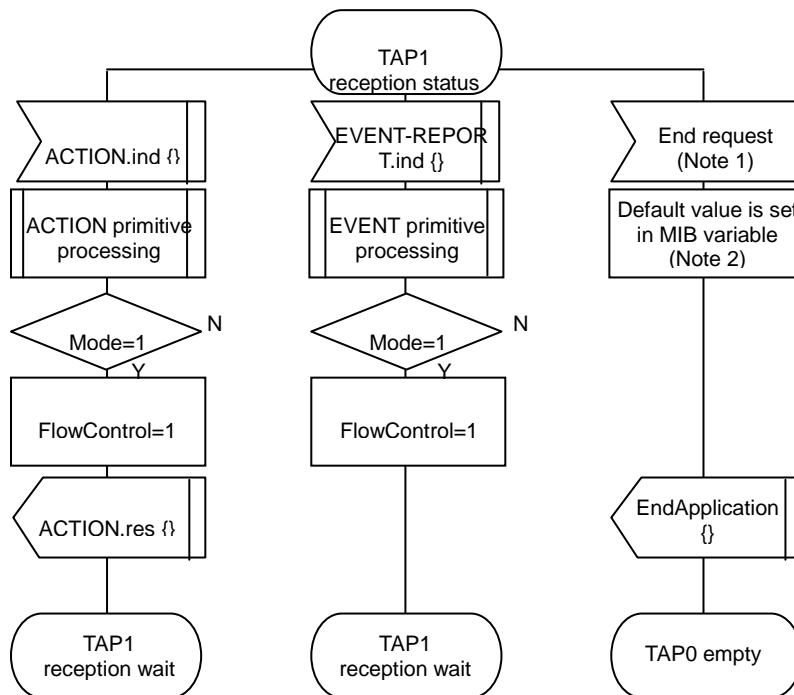

Fig A2.11.4 SDL for test program

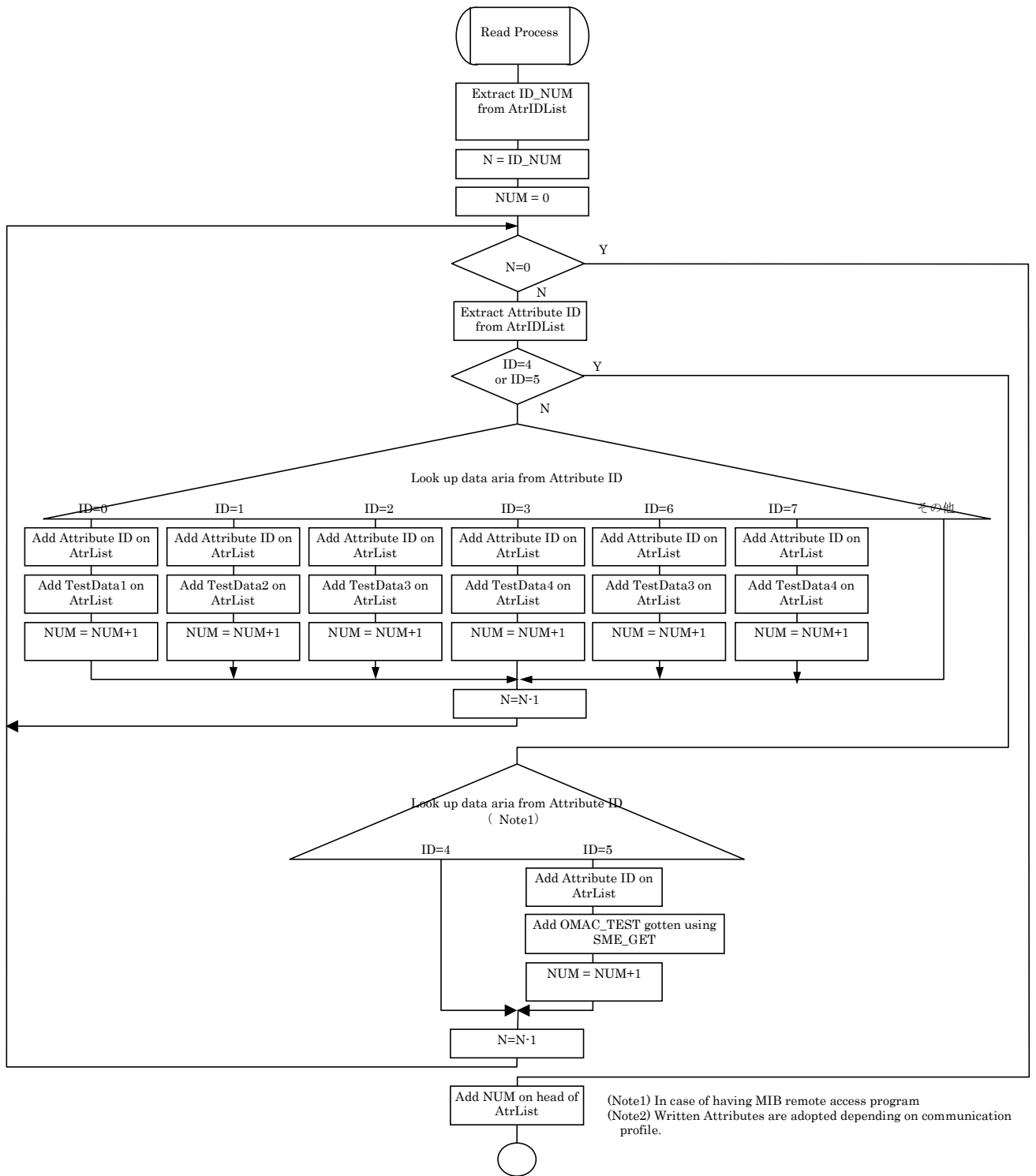

Fig A2.11.5 SDL for test program

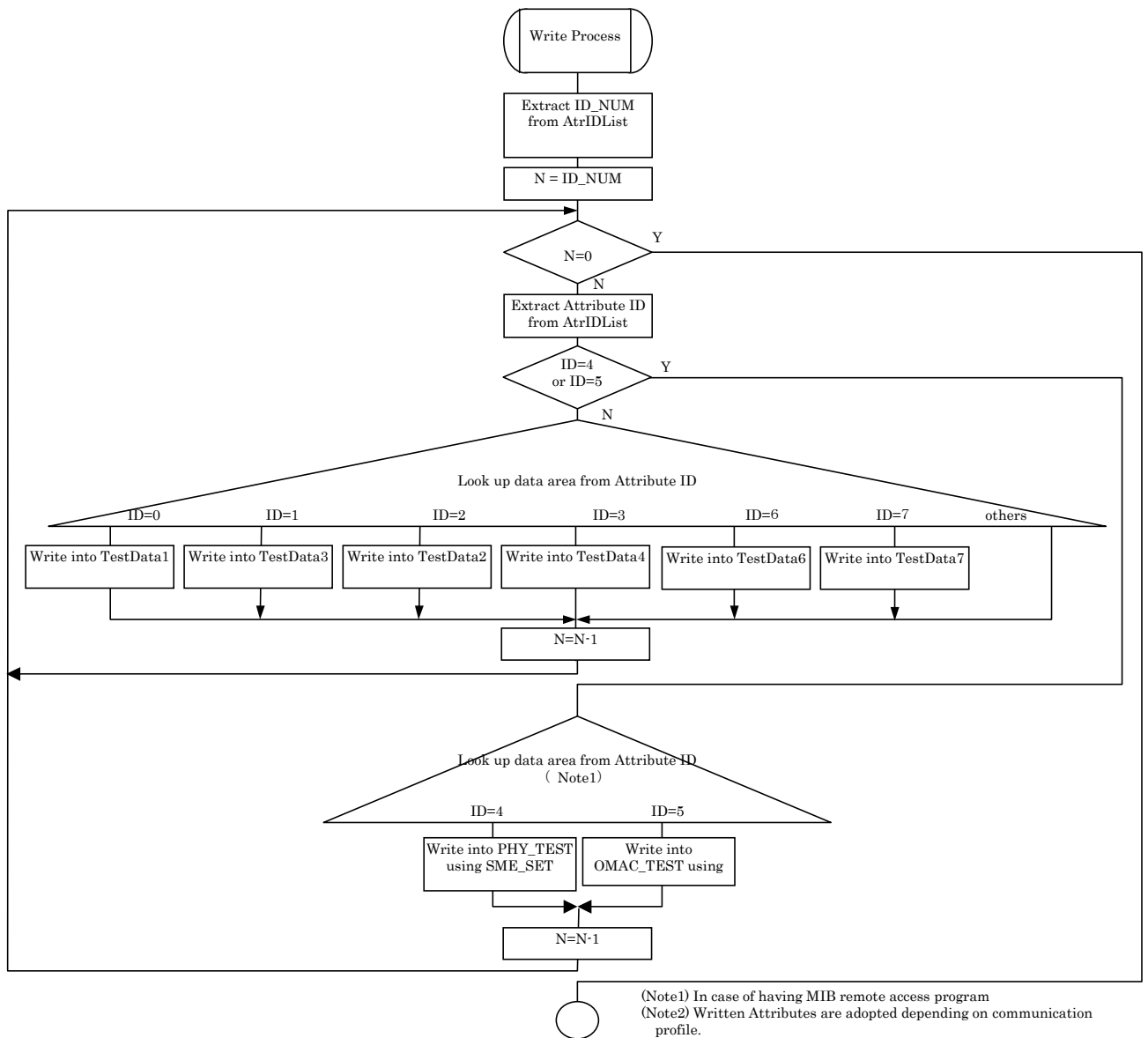

Fig. A2.11.6 SDL for test program

12 Transaction examples by the TE

The transaction example using test program by the TE is shown in Fig. A2.12.1.

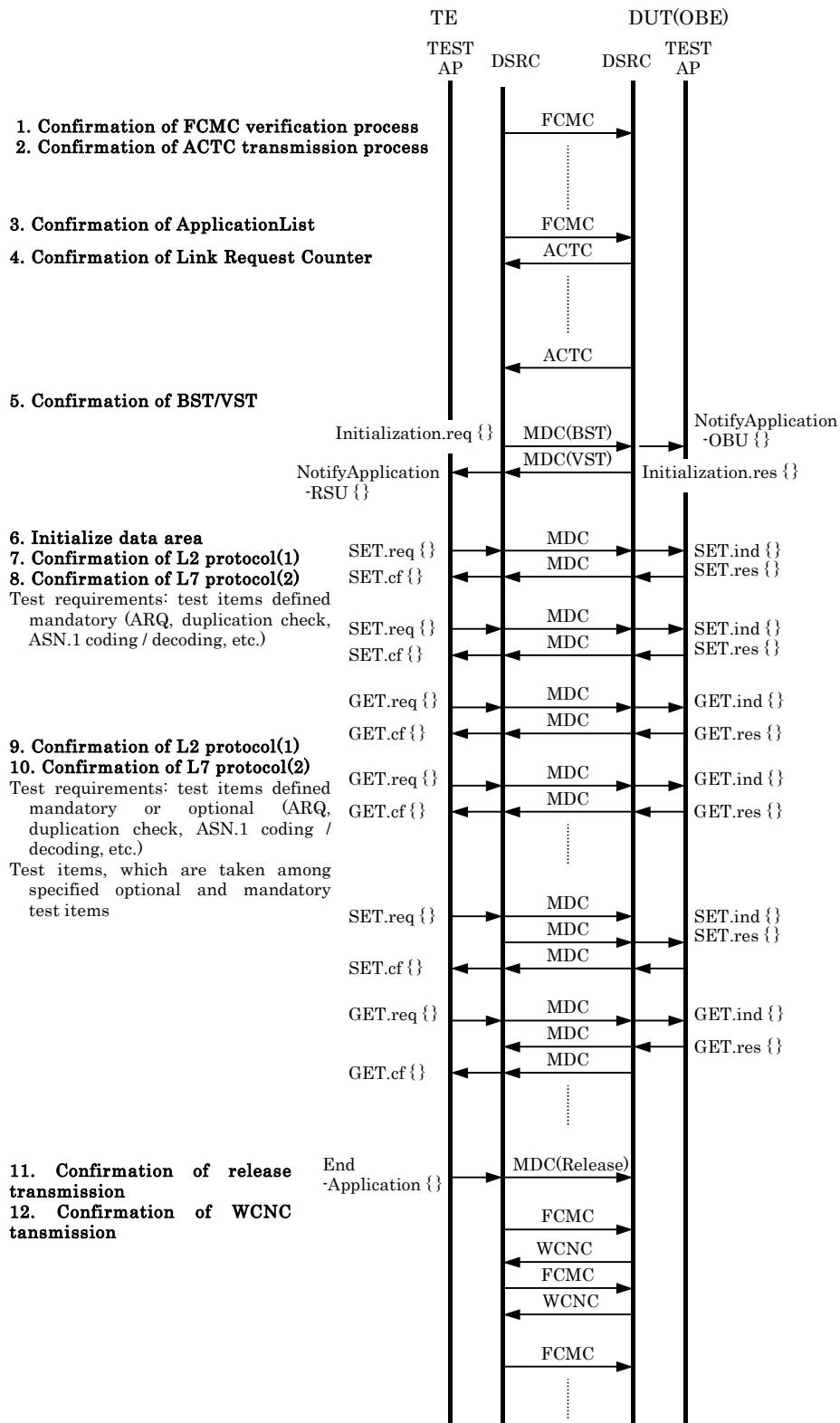

Fig. A2.12.1 the transaction example using test program by the TE

### **Annex 3 Relationship between the function classification of OBEs and test items by the test equipment**

The mobile station functions specified by the communication control method in DSRC System Standards (ARIB STD-T75) are classified as shown in Table A3-1

The mobile station basic functions are defined as the minimum required functions for communicating using the ARIB STD-T75 communication control method. The mobile station (OBE) application functions are defined as ARIB STD-T75 communication control method functions.

The test items from the test equipment are defined as mandatory items for verifying the basic functions, and the functions that are only defined as application functions are defined as optional items for verifying functions. Test items defined as optional are separately defined as to whether or they will be executed depending on the application. (This assumes the party operating the application will specify whether or not the functions will be executed when the mobile terminal is authorized.)

In addition, Table A3-2 shows the relationship between the test items defined during testing by the test equipment.

Table A3-1 Mobile station (OBE) function classification

Items		Basic Function	Application Function			
			Profile9	Profile10	Profile11	Profile12
Layer 1	Radio frequency	1:wave	2:wave	2:wave minimum	7:wave:	7:wave
	Frame length	Fixed	Elective by communication zone	Elective by communication zone	Elective by communication zone	Elective by communication zone
	Time divided frame	Not required	Required	Required	Required	Required
	Communication zone	Class 1	Class1 /Class 2	Class1 /Class 2	Class1 /Class 2	Class1 /Class 2
	Frequency selection	Not required	Required	Required	Required	Required
	Scramble	Not mandatory	Required	Required	Required	Required
	Modulation	ASK	ASK	ASK	ASK /QPSK	QPSK
Layer 2 (MAC sublayer)	ACTC transmission control	ACPI control	ACPI/STA control, SC control, PVI control	ACPI/STA control, SC control, PVI control	ACPI/STA control, SC control, PVI control	ACPI/STA control, SC control, PVI control
	Retry control	Required	Required	Required	Required	Required
	Duplication inspection	Required	Required	Required	Required	Required
	Division/assembly processing	Not required	Required	Required	Required	Required
	WCNC transmission	Required	Required For only required system	Required For only required system	Required For only required system	Required For only required system
	Modulation	ASK	ASK	ASK	ASK /QPSK	QPSK
	Broadcast	Not required	Required	Required	Required	Required
	Multicast	Not required	Required	Required	Required	Required
Layer 2 (LLC sublayer)	Type 1 operation	Required	Required	Required	Required	Required
	Type 3 operation	Not required	Not required	Not required	Not required	Not required

Note: The OBE shall not be abnormal operation mode at least passing communication zone, in which FCMC and MDS addressed broadcast or group address are transmitted. Test items for broadcast communication are to be specified in chapter 3, application interface conformance confirmation test.

Table A3-1 Mobile station (OBE) function classification (cont.)

Items		Basic Function	Application Function			
			Profile9	Profile10	Profile11	Profile12
Layer 7 (I-KE)	Link address creation	Fixed address is also OK	Random number generation	Random number generation	Random number generation	Random number generation
	Standard connection procedure	Required	Required	Required	Required	Required
	Abbreviated connection procedure	Not required	Not required	Not required	Not required	Not required
	Linked communication zone connection procedure	Not required	Required	Required	Required	Required
	Link disconnection processing	Required	Required	Required	Required	Required
	Release timer	2 sec. limit for RLT units	Supports all units	Supports all units	Supports all units	Supports all units
	Reconnection processing by request from application	Not required	Required	Required	Required	Required
Layer 7 (T-KE)	ASN.1 coding/decoding	Required	Required	Required	Required	Required
	Concatenation	Not required	Not required	Not required	Not required	Not required
	Multiplexer	Not required	Not required	Not required	Not required	Not required
	Octet matching	Required	Required	Required	Required	Required
Layer 7 (service interface)	GET	Required	Required	Required	Required	Required
	SET	Required	Required	Required	Required	Required
	ACTION	Not required	Required	Required	Required	Required
	EVENT-REPORT	Not required	Required	Required	Required	Required
Application	Connection timer	Required	Required	Required	Required	Required

Table A3-2 the relationship of test items between mobile terminal functions and test equipment

Items		Basic Function	Application Function			
			Profile9	Profile10	Profile11	Profile12
Layer 1	Radio frequency	(Note 1)	(Note 2)	(Note 2)	(Note 2)	(Note 2)
	Frame length	(Note 1)	(Note 2)	(Note 2)	(Note 2)	(Note 2)
	Time divided frame	(Note 1)	(Note 2)	(Note 2)	(Note 2)	(Note 2)
	Communication zone	(Note 1)	(Note 2)	(Note 2)	(Note 2)	(Note 2)
	Frequency selection	—	(Note 2)	(Note 2)	(Note 2)	(Note 2)
	Scramble	(Note 1)	2-1-11 2-1-12	2-1-11 2-1-12	2-1-11 2-1-12	2-1-11 2-1-12
	Modulation	—	—	—	(Note 4)	(Note 4)
Layer 2 (MAC sublayer)	ACTC transmission control	2-1-1, 2-1-2, 2-1-3, 2-1-4, 2-1-5	2-1-1, 2-1-2, 2-1-3, 2-1-4, 2-1-5 2-1-17	2-1-1, 2-1-2, 2-1-3, 2-1-4, 2-1-5 2-1-17	2-1-1, 2-1-2, 2-1-3, 2-1-4, 2-1-5 2-1-17	2-1-1, 2-1-2, 2-1-3, 2-1-4, 2-1-5 2-1-17
	Retry control	2-1-14, 2-1-15	2-1-14, 2-1-15	2-1-14, 2-1-15	(Note 4)	(Note 4)
	Duplication inspection	2-1-13	2-1-13	2-1-13	(Note 4)	(Note 4)
	Division/assembly processing	—	2-1-18	2-1-18	(Note 4)	(Note 4)
	WCNC transmission	2-1-16	2-1-16	2-1-16	2-1-16	2-1-16
	Modulation	—	—	—	(Note 4)	(Note 4)
	Broadcast	—	2-1-22	2-1-22	2-1-22	2-1-22
	Multicast	—	2-1-21	2-1-21	2-1-21	2-1-21
Layer 2 (LLC sublayer)	Type 1 operation	2-1-11 2-1-12	2-1-11 2-1-12	2-1-11 2-1-12	2-1-11 2-1-12	2-1-11 2-1-12
	Type 3 operation	—	—	—	—	—

Table A3-2 the relationship of test items between mobile terminal functions and test equipment (cont.)

Items		Basic Function	Application Function			
			Profile9	Profile10	Profile11	Profile12
Layer 7 (I-KE)	Link address creation	2-1-1	2-1-1	2-1-1	2-1-1	2-1-1
	Standard connection procedure	2-1-6, 2-1-7	2-1-6, 2-1-7, 2-1-8	2-1-6, 2-1-7, 2-1-8	2-1-6, 2-1-7, 2-1-8	2-1-6, 2-1-7, 2-1-8
	Abbreviated connection procedure	—	—	—	—	—
	Linked communication zone connection procedure	—	(Note 3)	(Note 3)	(Note 3)	(Note 3)
	Link disconnection processing	2-1-9, 2-1-10	2-1-9, 2-1-10 2-1-19 2-1-20	2-1-9, 2-1-10 2-1-19 2-1-20	2-1-9, 2-1-10 2-1-19 2-1-20	2-1-9, 2-1-10 2-1-19 2-1-20
	Release timer	2-1-9, 2-1-10	2-1-9, 2-1-10 2-1-19 2-1-20	2-1-9, 2-1-10 2-1-19 2-1-20	2-1-9, 2-1-10 2-1-19 2-1-20	2-1-9, 2-1-10 2-1-19 2-1-20
	Reconnection processing by request from application	—	(Note 3)	(Note 3)	(Note 3)	(Note 3)
Layer 7 (T-KE)	ASN.1 coding/decoding	2-1-11, 2-1-12	2-1-11, 2-1-12	2-1-11, 2-1-12	2-1-11, 2-1-12	2-1-11, 2-1-12
	Concatenation	—	—	—	—	—
	Multiplexer	—	—	—	—	—
	Division/assembly	—	—	—	—	—
	Chaining	—	—	—	—	—
Layer 7 (service interface)	GET	2-1-11, 2-1-12	2-1-11, 2-1-12	2-1-11, 2-1-12	2-1-11, 2-1-12	2-1-11, 2-1-12
	SET	2-1-11, 2-1-12	2-1-11, 2-1-12	2-1-11, 2-1-12	2-1-11, 2-1-12	2-1-11, 2-1-12
	ACTION	—	(Note 3)	(Note 3)	(Note 3)	(Note 3)
	EVENT-REPORT	—	(Note 3)	(Note 3)	(Note 3)	(Note 3)
Application	Connection timer	2-1-9, 2-1-10	2-1-9, 2-1-10 (Note 3)	2-1-9, 2-1-10 (Note 3)	2-1-9, 2-1-10 (Note 3)	2-1-9, 2-1-10 (Note 3)

Note 1: Test conditions when the basic function test is conducted.

Note 2: Execution of a compatibility confirmation test is scheduled and the test items will be prescribed later.

Note 3: These contains test items of application system test specified in chapter 3.

Note 4: Test items for  $\pi/4$  shift QPSK method is to be described.

Empty page

#### Annex 4 List of Test Items Using Test Equipment

Of the test items relating to the equipment technical requirements, the test times that are related to the transmission unit are listed in Table Annex 4-1, and the test times related to the transceiver unit are listed in Table Annex 4-2.

Also, of the test items related to the communication control method, the test items related to the basic operation test are listed in Table Annex 4-3, and the test items related to the dynamic operation test are listed in Table Annex 4.4.

Table A4-1-1 the technical requirements for radio facilities and equipments test  
(ASK method) – transmitter

Test number	Test Items	Category
1-1-1-A	frequency stability	M
1-1-2-A	occupied frequency bandwidth	M
1-1-3-A	transmission spurious	M
1-1-4-A	transmission power accuracy	M
1-1-5-A	adjacent channel leakage power	M
1-1-6-A	leakage power during carrier of period	M
1-1-7-A	transmission symbol rate accuracy	M
1-1-8-A	allowable deviation of absolute signal transmission time and burst transmission transient response time	M

M: Mandatory. O: Option. (Test items are adopted depending on application functions.)

Table A4-1-2 the technical requirements for radio facilities and equipments test  
( $\pi/4$  shift QPSK method) – transmitter

Test number	Test Items	Category
1-1-1-Q	frequency stability	M
1-1-2-Q	occupied frequency bandwidth	M
1-1-3-Q	transmission spurious	M
1-1-4-Q	transmission power accuracy	M
1-1-5-Q	adjacent channel leakage power	M
1-1-6-Q	leakage power during carrier of period	M
1-1-7-Q	transmission symbol rate accuracy	M
1-1-8-Q	allowable deviation of absolute signal transmission time and burst transmission transient response time	M

M: Mandatory. O: Option. (Test items are adopted depending on application function s.)

Table A4-2-1 the technical requirements for radio facilities and equipments test  
(ASK method) – receiver

Test number	Test Items	Category
1-2-1-A	reception sensitivity	M
1-2-2-A	strength of secondary radio emissions	M

M: Mandatory. O: Option. (Test items are adopted depending on application functions.)

Table A4-2-2 the technical requirements for radio facilities and equipments test  
( $\pi/4$  shift QPSK method) – receiver

Test number	Test Items	Category
1-2-1-Q	Reception sensitivity	M
1-2-2-Q	strength of secondary radio emissions	M

M: Mandatory. O: Option. (Test items are adopted depending on application functions.)

Table A4-3 communication protocol test – basic operation test

Test number	Test Items	Category
2-1-1	ACTC transmission in normal condition	M
2-1-2	ACTC transmission constraints – in case of reaching maximum transmission retry number	M
2-1-3	ACTC transmission constraints – in case of unable indication in an ACPI	M
2-1-4	ACTC transmission constraints – in case of reception of an FCMC registered corresponding LID	M
2-1-5	ACTC transmissions – in case of reception of an FCMC registered AIDs	M
2-1-6	BST reception	M
2-1-7	VST transmission	M
2-1-8	Initialization using communication profile(s)	O
2-1-9	Termination Procedures 1	M
2-1-10	Termination Procedures 2	M
2-1-11	Transaction test using one PDU	M
2-1-12	Transaction test using plural PDUs	M
2-1-13	Transaction test – duplication check of PDU	M
2-1-14	Transaction test – OBE retransmission	M
2-1-15	Transaction test – OBE retransmission request	M
2-1-16	WCNC transmissions	M
2-1-17	ACTC transmission control by STA in FCMC	O
2-1-18-1	Transaction test – fragmentation and de-fragmentation of PDU (ASK method)	O
2-1-18-2	Transaction test – fragmentation and de-fragmentation of PDU ( $\pi/4$ shift QPSK method)	O
2-1-19	Re-initialization in case of reception of release	O
2-1-20	Re-initialization in case of reception of release	O
2-1-21	Reception of PDU addressed multicast (group) address	O
2-1-22	Reception of PDU addressed broadcast address	O

M: Mandatory. O: Option. (Test items are adopted depending on application functions.)

Table A4-4 communication protocol test – Propagation simulation field operation test

Test number	Test Items	Category
2-2-1	Normal speed propagation simulation field operation test	
2-2-1-1	Normal speed propagation simulation field operation test – ideal profile – maximum input power at an OBE	M
2-2-1-2	Normal speed propagation simulation field operation test – ideal profile – minimum input power at an OBE	M
2-2-1-3	Normal speed propagation simulation field operation test – practical profile A	M
2-2-1-4	Normal speed propagation simulation field operation test – practical profile B	M
2-2-1-5	Normal speed propagation simulation field operation test –adjacent lane passing profile	M
2-2-1-6	Normal speed propagation simulation field operation test –shadowing profile	M
2-2-2	Low speed simulation field test	
2-2-2-1	Low speed propagation simulation field operation test – ideal profile – maximum input power at an OBE	M
2-2-2-2	Low speed propagation simulation field operation test – ideal profile – minimum input power at an OBE	M
2-2-2-3	Low speed propagation simulation field operation test – practical profile A	M
2-2-2-4	Low speed propagation simulation field operation test – practical profile B	M
2-2-2-5	Low speed propagation simulation field operation test –adjacent lane passing profile	M
2-2-2-6	Low speed propagation simulation field operation test –shadowing profile	M
2-2-3	High speed simulation field test	
2-2-3-1	High speed propagation simulation field operation test – ideal profile – maximum input power at an OBE	M
2-2-3-2	High speed propagation simulation field operation test – ideal profile – minimum input power at an OBE	M
2-2-3-3	High speed propagation simulation field operation test – practical profile A	M
2-2-3-4	High speed propagation simulation field operation test – practical profile B	M
2-2-3-5	High speed propagation simulation field operation test –adjacent lane passing profile	M
2-2-3-6	High speed propagation simulation field operation test –shadowing profile	M

M: Mandatory. O: Option. (Test items are adopted depending on application functions.)

## **Annex 5 Compatibility conformance confirmation test between ARIB STD-T55 and ARIB STD-T75 for ETC**

### 1. Outline

On September 2001, communication standard ARIB STD-T55 is applied for Electronic Toll Collection System (ETC). ETC base stations and mobile stations (OBEs) manufactured or/and implied until March 202 are allowed to use until March 2012. On After April 2002, new communication standard ARIB STD-T75 will be applied for ETC equipments (base station and/or mobile station (OBE)), that will be certificated of the test for the technical requirements for radio facilities and equipments test and manufactured.

Therefore, on after April 2002, base stations and OBEs, that are conformance with Standard ARIB STD-T55 or ARIB STD-T75, are operated together on ETC system. Considering to this situation, Compatibility conformance confirmation test between ARIB STD-T55 and ARIB STD-T75 for ETC is required to maintain smoothly ETC operation having compatibility between devices that are conformance with different standard.

The interoperability test of ETC application is conducted as the ETC application interoperability conformance confirmation tests issued by ORSE (Organization for Road System Enhancement: <http://www.orse.or.jp/>) and /or other test authorities. Therefore, this annex only specifies the basic operation test (DSRC conformance confirmation test).

### 2. Scope

The test confirms that the DUT (ETC OBE) for Electronic Toll Collection System standard ARIB STD-T55 or, for DSRC system standard ARIB STD-T75 could communicate with the base station, which is conformance with different ARIB STD from own standard. The TE should conduct this compatibility conformance confirmation test for these OBEs.

### 3. Objective of compatibility conformance confirmation test

The DUT (ETC OBE) shall adopt test items in chapter 2 of the technical report “TR-T8: Electronic Toll Collection System TEST ITEMS AND CONDITIONS FOR MOBILE STATION COMPATIBILITY CONFIRMATION” referred to ARIB STD-T55 and in chapter 2 (ASK method) of the technical report “DSRC System TEST ITEMS AND CONDITIONS FOR MOBILE STATION COMPATIBILITY CONFIRMATION” referred to ARIB STD-T75 for maintaining compatibility with ARIB STD-T55 or ARIB STD-T75.

Each TE has the test program for ETC system standard ARIB STD-T55 or DSRC system

**ARIB TR-T16**

standard ARIB STD-T75 for the DUT (OBE) respectively. The DUT (OBE) for each standard also has the test program, which is specified in annex 2 of TR-T8 or TR-T16. Furthermore, these test programs could conduct the same test sequence.

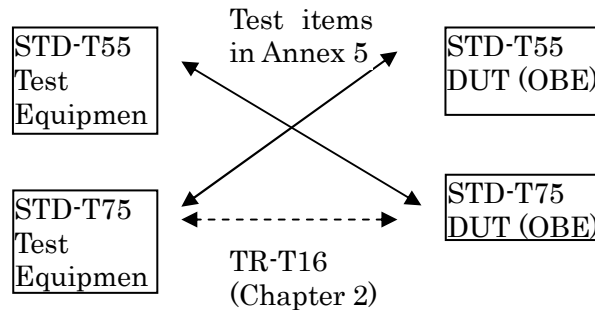

Fig. A5.1 Scope of compatibility conformance confirmation test in this annex 5.

**4. Test items and test conditions**

Compatibility conformance confirmation test of the DUT (OBE) for ARIB STD-T75 by the TE for ARIB STD-T55 and Compatibility conformance confirmation test of the DUT (OBE) for ARIB STD-T55 by the TE for ARIB STD-T75 should be conducted as shown bowled lines in Fig. A5.1. Test items for these tests are specified in following sub-clause.

In tests, the test program, which is specified in Annex 2 of TR-T8 or TR-T16, is used and the tests are conducted only for the basic operation test for each test items.

**4.1 Compatibility test of the DUT (OBE) for ARIB STD-T75 for by the TE for ARIB STD-T55**

The test of chapter 2 of TR-T8 is adopted. (Test items are shown as following list.) The test should apply test parameters and test sequence (protocol) of chapter 2 in TR-T8. Where, the communication profile shall be 9 and AID shall be 14. Furthermore, the connection time notified by the DUT is adopted.

<u>test number</u>	<u>test items</u>
2-1	basic operation test
2-1-1	ACTC transmissions in normal condition
2-1-2	ACTC transmission constraints – in case of reaching maximum transmission retry number
2-1-3	ACTC transmission constraints – in case of unable indication in an ACPI
2-1-4	ACTC transmission constraints – in case of reception of an FCMC registered corresponding LID
2-1-5	BST reception
2-1-6	VST transmission
2-1-7	Termination Procedures 1
2-1-8	Termination Procedures 2
2-1-9	Transaction test using one PDU
2-1-10	Transaction test using plural PDUs
2-1-11	Transaction test – duplication check of PDU
2-1-12	Transaction test – OBE retransmission
2-1-13	Transaction test – OBE retransmission request
2-1-14	WCNC transmission
2-1-15	ACTC transmission control by STA in FCMC
2-1-16	Transaction test – fragmentation and de-fragmentation of PDU
2-1-17	Termination Procedures 3
2-1-18	Re-initialization in case of reception of release

4.2 Compatibility test for the DUT (OBE) for ARIB STD-T55 by the TE for ARIB STD-T75  
 The test of chapter 2 (ASK method) of TR-T16 is adopted. (Test items are shown as following list.) The test should apply test parameters and test sequence (protocol) of chapter 2 in TR-T16. Where, the communication profile shall be 9 and AID shall be 14.  
 Furthermore, the connection time notified by the DUT is adopted.

In below table for the basic operation test, “n.a” means “ not applicable”. However corresponding test items shall be conducted and test results would not be verified.

<u>test number</u>	<u>test items</u>
2-1	basic operation test
2-1-1	ACTC transmissions in normal condition
2-1-2	ACTC transmission constraints – in case of reaching maximum transmission retry number
2-1-3	ACTC transmission constraints – in case of unable indication in an ACPI
2-1-4	ACTC transmission constraints – in case of reception of an FCMC registered corresponding LID
2-1-5	ACTC transmissions – in case of reception of an FCMC registered AIDs (n.a)
2-1-6	BST reception
2-1-7	VST transmission
2-1-8	Initialization using communication profile(s) (n.a)
2-1-9	Termination Procedures 1
2-1-10	Termination Procedures 2
2-1-11	Transaction test using one PDU
2-1-12	Transaction test using plural PDUs
2-1-13	Transaction test – duplication check of PDU
2-1-14	Transaction test – OBE retransmission
2-1-15	Transaction test – OBE retransmission request
2-1-16	WCNC transmissions
2-1-17	ACTC transmission control by STA in FCMC
2-1-18	Transaction test – fragmentation and de-fragmentation of PDU
2-1-19	Termination Procedures 3 (Note)
2-1-20	Re-initialization in case of reception of release
2-1-21	Reception of PDU addressed multicast (group) address (n.a)
2-1-22	Reception of PDU addressed broadcast address (n.a)

---

DEDICATED SHORT-RANGE  
COMMUNICATION SYSTEM

TEST ITEMS AND CONDITIONS FOR MOBILE STATION  
COMPATIBILITY CONFIRMATION

ARIB TECHNICAL REPORT

ARIB TR-T16 VERSION 1.0

---

Version 1.0 September 2001

Published by  
Association of Radio Industries and Businesses

Nittochi Bldg. 11F  
1-4-1 Kasumigaseki, Chiyoda-ku, Tokyo 100-0013, Japan  
TEL 81-3-5510-8590  
FAX 81-3-3592-1103

Printed in Japan  
All rights reserved

---