



**ARIB STD-T104-36.212 V10.9.0**

**Evolved Universal Terrestrial Radio  
Access (E-UTRA); Multiplexing and  
channel coding**

**(Release 10)**

# 3GPP TS 36.212 V10.9.0 (2015-09)

---

*Technical Specification*

**3<sup>rd</sup> Generation Partnership Project;  
Technical Specification Group Radio Access Network;  
Evolved Universal Terrestrial Radio Access (E-UTRA);  
Multiplexing and channel coding  
(Release 10)**



The present document has been developed within the 3<sup>rd</sup> Generation Partnership Project (3GPP<sup>TM</sup>) and may be further elaborated for the purposes of 3GPP. The present document has not been subject to any approval process by the 3GPP Organizational Partners and shall not be implemented. This Specification is provided for future development work within 3GPP only. The Organizational Partners accept no liability for any use of this Specification. Specifications and reports for implementation of the 3GPP<sup>TM</sup> system should be obtained via the 3GPP Organizational Partners' Publications Offices.

---

---

Keywords

<keyword[, keyword]>

**3GPP**

---

Postal address

---

3GPP support office address

650 Route des Lucioles – Sophia Antipolis  
Valbonne – France  
Tel. : +33 4 92 94 42 00 Fax : +33 4 93 65 47 16

---

Internet

<http://www.3gpp.org>

---

**Copyright Notification**

No part may be reproduced except as authorized by written permission.  
The copyright and the foregoing restriction extend to reproduction in all media.

© 2015, 3GPP Organizational Partners (ARIB, ATIS, CCSA, ETSI, TSDSI, TTA, TTC).  
All rights reserved.

UMTS™ is a Trade Mark of ETSI registered for the benefit of its members  
3GPP™ is a Trade Mark of ETSI registered for the benefit of its Members and of the 3GPP Organizational Partners  
LTE™ is a Trade Mark of ETSI registered for the benefit of its Members and of the 3GPP Organizational Partners  
GSM® and the GSM logo are registered and owned by the GSM Association

# Contents

Foreword.....	5
1 Scope.....	6
2 References.....	6
3 Definitions, symbols and abbreviations .....	6
3.1 Definitions .....	6
3.2 Symbols .....	6
3.3 Abbreviations.....	7
4 Mapping to physical channels.....	7
4.1 Uplink.....	7
4.2 Downlink .....	8
5 Channel coding, multiplexing and interleaving .....	8
5.1 Generic procedures .....	8
5.1.1 CRC calculation .....	8
5.1.2 Code block segmentation and code block CRC attachment.....	9
5.1.3 Channel coding.....	11
5.1.3.1 Tail biting convolutional coding.....	11
5.1.3.2 Turbo coding .....	12
5.1.3.2.1 Turbo encoder .....	12
5.1.3.2.2 Trellis termination for turbo encoder .....	13
5.1.3.2.3 Turbo code internal interleaver .....	13
5.1.4 Rate matching.....	15
5.1.4.1 Rate matching for turbo coded transport channels .....	15
5.1.4.1.1 Sub-block interleaver .....	15
5.1.4.1.2 Bit collection, selection and transmission.....	16
5.1.4.2 Rate matching for convolutionally coded transport channels and control information .....	18
5.1.4.2.1 Sub-block interleaver .....	19
5.1.4.2.2 Bit collection, selection and transmission.....	20
5.1.5 Code block concatenation .....	20
5.2 Uplink transport channels and control information .....	21
5.2.1 Random access channel.....	21
5.2.2 Uplink shared channel.....	21
5.2.2.1 Transport block CRC attachment .....	22
5.2.2.2 Code block segmentation and code block CRC attachment .....	22
5.2.2.3 Channel coding of UL-SCH .....	23
5.2.2.4 Rate matching.....	23
5.2.2.5 Code block concatenation.....	23
5.2.2.6 Channel coding of control information.....	23
5.2.2.6.1 Channel quality information formats for wideband CQI reports .....	33
5.2.2.6.2 Channel quality information formats for higher layer configured subband CQI reports .....	34
5.2.2.6.3 Channel quality information formats for UE selected subband CQI reports .....	35
5.2.2.6.4 Channel coding for CQI/PMI information in PUSCH .....	37
5.2.2.6.5 Channel coding for more than 11 bits of HARQ-ACK information.....	38
5.2.2.7 Data and control multiplexing .....	38
5.2.2.8 Channel interleaver.....	39
5.2.3 Uplink control information on PUCCH .....	41
5.2.3.1 Channel coding for UCI HARQ-ACK .....	41
5.2.3.2 Channel coding for UCI scheduling request.....	45
5.2.3.3 Channel coding for UCI channel quality information .....	45
5.2.3.3.1 Channel quality information formats for wideband reports .....	46
5.2.3.3.2 Channel quality information formats for UE-selected sub-band reports.....	48
5.2.3.4 Channel coding for UCI channel quality information and HARQ-ACK.....	51
5.2.4 Uplink control information on PUSCH without UL-SCH data.....	51
5.2.4.1 Channel coding of control information.....	51
5.2.4.2 Control information mapping .....	52

5.2.4.3	Channel interleaver.....	53
5.3	Downlink transport channels and control information.....	53
5.3.1	Broadcast channel .....	53
5.3.1.1	Transport block CRC attachment .....	53
5.3.1.2	Channel coding.....	54
5.3.1.3	Rate matching.....	54
5.3.2	Downlink shared channel, Paging channel and Multicast channel.....	54
5.3.2.1	Transport block CRC attachment .....	55
5.3.2.2	Code block segmentation and code block CRC attachment .....	55
5.3.2.3	Channel coding.....	56
5.3.2.4	Rate matching.....	56
5.3.2.5	Code block concatenation.....	56
5.3.3	Downlink control information.....	56
5.3.3.1	DCI formats.....	57
5.3.3.1.1	Format 0.....	57
5.3.3.1.2	Format 1.....	58
5.3.3.1.3	Format 1A.....	59
5.3.3.1.3A	Format 1B.....	61
5.3.3.1.4	Format 1C.....	62
5.3.3.1.4A	Format 1D.....	63
5.3.3.1.5	Format 2.....	64
5.3.3.1.5A	Format 2A.....	67
5.3.3.1.5B	Format 2B.....	69
5.3.3.1.5C	Format 2C.....	70
5.3.3.1.6	Format 3.....	71
5.3.3.1.7	Format 3A.....	72
5.3.3.1.8	Format 4.....	72
5.3.3.2	CRC attachment.....	74
5.3.3.3	Channel coding.....	75
5.3.3.4	Rate matching.....	75
5.3.4	Control format indicator.....	75
5.3.4.1	Channel coding.....	75
5.3.5	HARQ indicator (HI).....	76
5.3.5.1	Channel coding.....	76
<b>Annex A (informative):</b>	<b>Change history .....</b>	<b>77</b>

---

## Foreword

This Technical Specification has been produced by the 3<sup>rd</sup> Generation Partnership Project (3GPP).

The contents of the present document are subject to continuing work within the TSG and may change following formal TSG approval. Should the TSG modify the contents of the present document, it will be re-released by the TSG with an identifying change of release date and an increase in version number as follows:

Version x.y.z

where:

x the first digit:

- 1 presented to TSG for information;
- 2 presented to TSG for approval;
- 3 or greater indicates TSG approved document under change control.

Y the second digit is incremented for all changes of substance, i.e. technical enhancements, corrections, updates, etc.

z the third digit is incremented when editorial only changes have been incorporated in the document.

---

# 1 Scope

The present document specifies the coding, multiplexing and mapping to physical channels for E-UTRA.

---

# 2 References

The following documents contain provisions which, through reference in this text, constitute provisions of the present document.

- References are either specific (identified by date of publication, edition number, version number, etc.) or non-specific.
- For a specific reference, subsequent revisions do not apply.
- For a non-specific reference, the latest version applies. In the case of a reference to a 3GPP document (including a GSM document), a non-specific reference implicitly refers to the latest version of that document *in the same Release as the present document*.

- [1] 3GPP TR 21.905: "Vocabulary for 3GPP Specifications".
  - [2] 3GPP TS 36.211: "Evolved Universal Terrestrial Radio Access (E-UTRA); Physical channels and modulation".
  - [3] 3GPP TS 36.213: "Evolved Universal Terrestrial Radio Access (E-UTRA); Physical layer procedures".
  - [4] 3GPP TS 36.306: "Evolved Universal Terrestrial Radio Access (E-UTRA); User Equipment (UE) radio access capabilities".
  - [5] 3GPP TS36.321, "Evolved Universal Terrestrial Radio Access (E-UTRA); Medium Access Control (MAC) protocol specification"
  - [6] 3GPP TS36.331, "Evolved Universal Terrestrial Radio Access (E-UTRA); Radio Resource Control (RRC) protocol specification"
- 

# 3 Definitions, symbols and abbreviations

## 3.1 Definitions

For the purposes of the present document, the terms and definitions given in [1] and the following apply. A term defined in the present document takes precedence over the definition of the same term, if any, in [1].

*Definition format*

*<defined term>: <definition>.*

## 3.2 Symbols

For the purposes of the present document, the following symbols apply:

$N_{RB}^{DL}$	Downlink bandwidth configuration, expressed in number of resource blocks [2]
$N_{RB}^{UL}$	Uplink bandwidth configuration, expressed in number of resource blocks [2]
$N_{sc}^{RB}$	Resource block size in the frequency domain, expressed as a number of subcarriers

$N_{\text{symb}}^{\text{PUSCH}}$	Number of SC-FDMA symbols carrying PUSCH in a subframe
$N_{\text{symb}}^{\text{PUSCH-initial}}$	Number of SC-FDMA symbols carrying PUSCH in the initial PUSCH transmission subframe
$N_{\text{symb}}^{\text{UL}}$	Number of SC-FDMA symbols in an uplink slot
$N_{\text{SRS}}$	Number of SC-FDMA symbols used for SRS transmission in a subframe (0 or 1).

### 3.3 Abbreviations

For the purposes of the present document, the following abbreviations apply:

BCH	Broadcast channel
CFI	Control Format Indicator
CP	Cyclic Prefix
DCI	Downlink Control Information
DL-SCH	Downlink Shared channel
FDD	Frequency Division Duplexing
HI	HARQ indicator
MCH	Multicast channel
PBCH	Physical Broadcast channel
PCFICH	Physical Control Format Indicator channel
PCH	Paging channel
PDCCH	Physical Downlink Control channel
PDSCH	Physical Downlink Shared channel
PHICH	Physical HARQ indicator channel
PMCH	Physical Multicast channel
PMI	Precoding Matrix Indicator
PRACH	Physical Random Access channel
PUCCH	Physical Uplink Control channel
PUSCH	Physical Uplink Shared channel
RACH	Random Access channel
RI	Rank Indication
SR	Scheduling Request
SRS	Sounding Reference Signal
TDD	Time Division Duplexing
TPMI	Transmitted Precoding Matrix Indicator
UCI	Uplink Control Information
UL-SCH	Uplink Shared channel

---

## 4 Mapping to physical channels

### 4.1 Uplink

Table 4.1-1 specifies the mapping of the uplink transport channels to their corresponding physical channels. Table 4.1-2 specifies the mapping of the uplink control channel information to its corresponding physical channel.



Table 4.1-1

TrCH	Physical Channel
UL-SCH	PUSCH
RACH	PRACH

Table 4.1-2

Control information	Physical Channel
UCI	PUCCH, PUSCH

## 4.2 Downlink

Table 4.2-1 specifies the mapping of the downlink transport channels to their corresponding physical channels. Table 4.2-2 specifies the mapping of the downlink control channel information to its corresponding physical channel.

Table 4.2-1

TrCH	Physical Channel
DL-SCH	PDSCH
BCH	PBCH
PCH	PDSCH
MCH	PMCH

Table 4.2-2

Control information	Physical Channel
CFI	PCFICH
HI	PHICH
DCI	PDCCH

---

# 5 Channel coding, multiplexing and interleaving

Data and control streams from/to MAC layer are encoded /decoded to offer transport and control services over the radio transmission link. Channel coding scheme is a combination of error detection, error correcting, rate matching, interleaving and transport channel or control information mapping onto/splitting from physical channels.

## 5.1 Generic procedures

This section contains coding procedures which are used for more than one transport channel or control information type.

### 5.1.1 CRC calculation

Denote the input bits to the CRC computation by  $a_0, a_1, a_2, a_3, \dots, a_{A-1}$ , and the parity bits by  $p_0, p_1, p_2, p_3, \dots, p_{L-1}$ .  $A$  is the size of the input sequence and  $L$  is the number of parity bits. The parity bits are generated by one of the following cyclic generator polynomials:

- $g_{\text{CRC24A}}(D) = [D^{24} + D^{23} + D^{18} + D^{17} + D^{14} + D^{11} + D^{10} + D^7 + D^6 + D^5 + D^4 + D^3 + D + 1]$  and;
- $g_{\text{CRC24B}}(D) = [D^{24} + D^{23} + D^6 + D^5 + D + 1]$  for a CRC length  $L = 24$  and;
- $g_{\text{CRC16}}(D) = [D^{16} + D^{12} + D^5 + 1]$  for a CRC length  $L = 16$ .
- $g_{\text{CRC8}}(D) = [D^8 + D^7 + D^4 + D^3 + D + 1]$  for a CRC length of  $L = 8$ .

The encoding is performed in a systematic form, which means that in GF(2), the polynomial:

$$a_0D^{A+23} + a_1D^{A+22} + \dots + a_{A-1}D^{24} + p_0D^{23} + p_1D^{22} + \dots + p_{22}D^1 + p_{23}$$

yields a remainder equal to 0 when divided by the corresponding length-24 CRC generator polynomial,  $g_{\text{CRC24A}}(D)$  or  $g_{\text{CRC24B}}(D)$ , the polynomial:

$$a_0D^{A+15} + a_1D^{A+14} + \dots + a_{A-1}D^{16} + p_0D^{15} + p_1D^{14} + \dots + p_{14}D^1 + p_{15}$$

yields a remainder equal to 0 when divided by  $g_{\text{CRC16}}(D)$ , and the polynomial:

$$a_0D^{A+7} + a_1D^{A+6} + \dots + a_{A-1}D^8 + p_0D^7 + p_1D^6 + \dots + p_6D^1 + p_7$$

yields a remainder equal to 0 when divided by  $g_{\text{CRC8}}(D)$ .

The bits after CRC attachment are denoted by  $b_0, b_1, b_2, b_3, \dots, b_{B-1}$ , where  $B = A + L$ . The relation between  $a_k$  and  $b_k$  is:

$$\begin{aligned} b_k &= a_k & \text{for } k = 0, 1, 2, \dots, A-1 \\ b_k &= p_{k-A} & \text{for } k = A, A+1, A+2, \dots, A+L-1. \end{aligned}$$

## 5.1.2 Code block segmentation and code block CRC attachment

The input bit sequence to the code block segmentation is denoted by  $b_0, b_1, b_2, b_3, \dots, b_{B-1}$ , where  $B > 0$ . If  $B$  is larger than the maximum code block size  $Z$ , segmentation of the input bit sequence is performed and an additional CRC sequence of  $L = 24$  bits is attached to each code block. The maximum code block size is:

- $Z = 6144$ .

If the number of filler bits  $F$  calculated below is not 0, filler bits are added to the beginning of the first block.

Note that if  $B < 40$ , filler bits are added to the beginning of the code block.

The filler bits shall be set to  $\langle \text{NULL} \rangle$  at the input to the encoder.

Total number of code blocks  $C$  is determined by:

if  $B \leq Z$

$$L = 0$$

$$\text{Number of code blocks: } C = 1$$

$$B' = B$$

else

$$L = 24$$

$$\text{Number of code blocks: } C = \lceil B / (Z - L) \rceil.$$

$$B' = B + C \cdot L$$

end if

The bits output from code block segmentation, for  $C \neq 0$ , are denoted by  $c_{r0}, c_{r1}, c_{r2}, c_{r3}, \dots, c_{r(K_r-1)}$ , where  $r$  is the code block number, and  $K_r$  is the number of bits for the code block number  $r$ .

Number of bits in each code block (applicable for  $C \neq 0$  only):

First segmentation size:  $K_+ = \text{minimum } K \text{ in table 5.1.3-3 such that } C \cdot K \geq B'$



end for

### 5.1.3 Channel coding

The bit sequence input for a given code block to channel coding is denoted by  $c_0, c_1, c_2, c_3, \dots, c_{K-1}$ , where  $K$  is the number of bits to encode. After encoding the bits are denoted by  $d_0^{(i)}, d_1^{(i)}, d_2^{(i)}, d_3^{(i)}, \dots, d_{D-1}^{(i)}$ , where  $D$  is the number of encoded bits per output stream and  $i$  indexes the encoder output stream. The relation between  $c_k$  and  $d_k^{(i)}$  and between  $K$  and  $D$  is dependent on the channel coding scheme.

The following channel coding schemes can be applied to TrCHs:

- tail biting convolutional coding;
- turbo coding.

Usage of coding scheme and coding rate for the different types of TrCH is shown in table 5.1.3-1. Usage of coding scheme and coding rate for the different control information types is shown in table 5.1.3-2.

The values of  $D$  in connection with each coding scheme:

- tail biting convolutional coding with rate 1/3:  $D = K$ ;
- turbo coding with rate 1/3:  $D = K + 4$ .

The range for the output stream index  $i$  is 0, 1 and 2 for both coding schemes.

**Table 5.1.3-1: Usage of channel coding scheme and coding rate for TrCHs.**

TrCH	Coding scheme	Coding rate
UL-SCH	Turbo coding	1/3
DL-SCH		
PCH		
MCH		
BCH	Tail biting convolutional coding	1/3

**Table 5.1.3-2: Usage of channel coding scheme and coding rate for control information.**

Control Information	Coding scheme	Coding rate
DCI	Tail biting convolutional coding	1/3
CFI	Block code	1/16
HI	Repetition code	1/3
UCI	Block code	variable
	Tail biting convolutional coding	1/3

#### 5.1.3.1 Tail biting convolutional coding

A tail biting convolutional code with constraint length 7 and coding rate 1/3 is defined.

The configuration of the convolutional encoder is presented in figure 5.1.3-1.

The initial value of the shift register of the encoder shall be set to the values corresponding to the last 6 information bits in the input stream so that the initial and final states of the shift register are the same. Therefore, denoting the shift register of the encoder by  $s_0, s_1, s_2, \dots, s_5$ , then the initial value of the shift register shall be set to

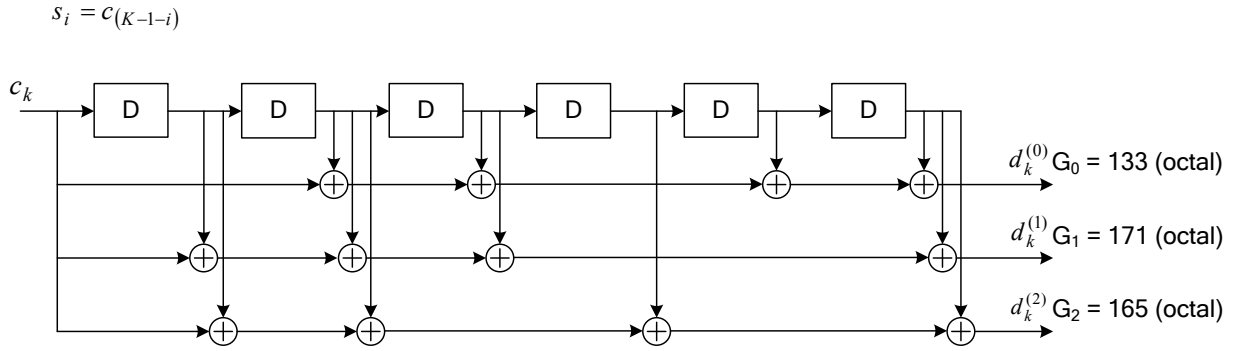

**Figure 5.1.3-1: Rate 1/3 tail biting convolutional encoder.**

The encoder output streams  $d_k^{(0)}$ ,  $d_k^{(1)}$  and  $d_k^{(2)}$  correspond to the first, second and third parity streams, respectively as shown in Figure 5.1.3-1.

### 5.1.3.2 Turbo coding

#### 5.1.3.2.1 Turbo encoder

The scheme of turbo encoder is a Parallel Concatenated Convolutional Code (PCCC) with two 8-state constituent encoders and one turbo code internal interleaver. The coding rate of turbo encoder is 1/3. The structure of turbo encoder is illustrated in figure 5.1.3-2.

The transfer function of the 8-state constituent code for the PCCC is:

$$G(D) = \begin{bmatrix} 1, \frac{g_1(D)}{g_0(D)} \\ g_0(D) \end{bmatrix},$$

where

$$g_0(D) = 1 + D^2 + D^3,$$

$$g_1(D) = 1 + D + D^3.$$

The initial value of the shift registers of the 8-state constituent encoders shall be all zeros when starting to encode the input bits.

The output from the turbo encoder is

$$d_k^{(0)} = x_k$$

$$d_k^{(1)} = z_k$$

$$d_k^{(2)} = z'_k$$

for  $k = 0, 1, 2, \dots, K-1$ .

If the code block to be encoded is the 0-th code block and the number of filler bits is greater than zero, i.e.,  $F > 0$ , then the encoder shall set  $c_k = 0$ ,  $k = 0, \dots, (F-1)$  at its input and shall set  $d_k^{(0)} = \langle \text{NULL} \rangle$ ,  $k = 0, \dots, (F-1)$  and

$d_k^{(1)} = \langle \text{NULL} \rangle$ ,  $k = 0, \dots, (F-1)$  at its output.

The bits input to the turbo encoder are denoted by  $c_0, c_1, c_2, c_3, \dots, c_{K-1}$ , and the bits output from the first and second 8-state constituent encoders are denoted by  $z_0, z_1, z_2, z_3, \dots, z_{K-1}$  and  $z'_0, z'_1, z'_2, z'_3, \dots, z'_{K-1}$ , respectively. The bits output from the turbo code internal interleaver are denoted by  $c'_0, c'_1, \dots, c'_{K-1}$ , and these bits are to be the input to the second 8-state constituent encoder.

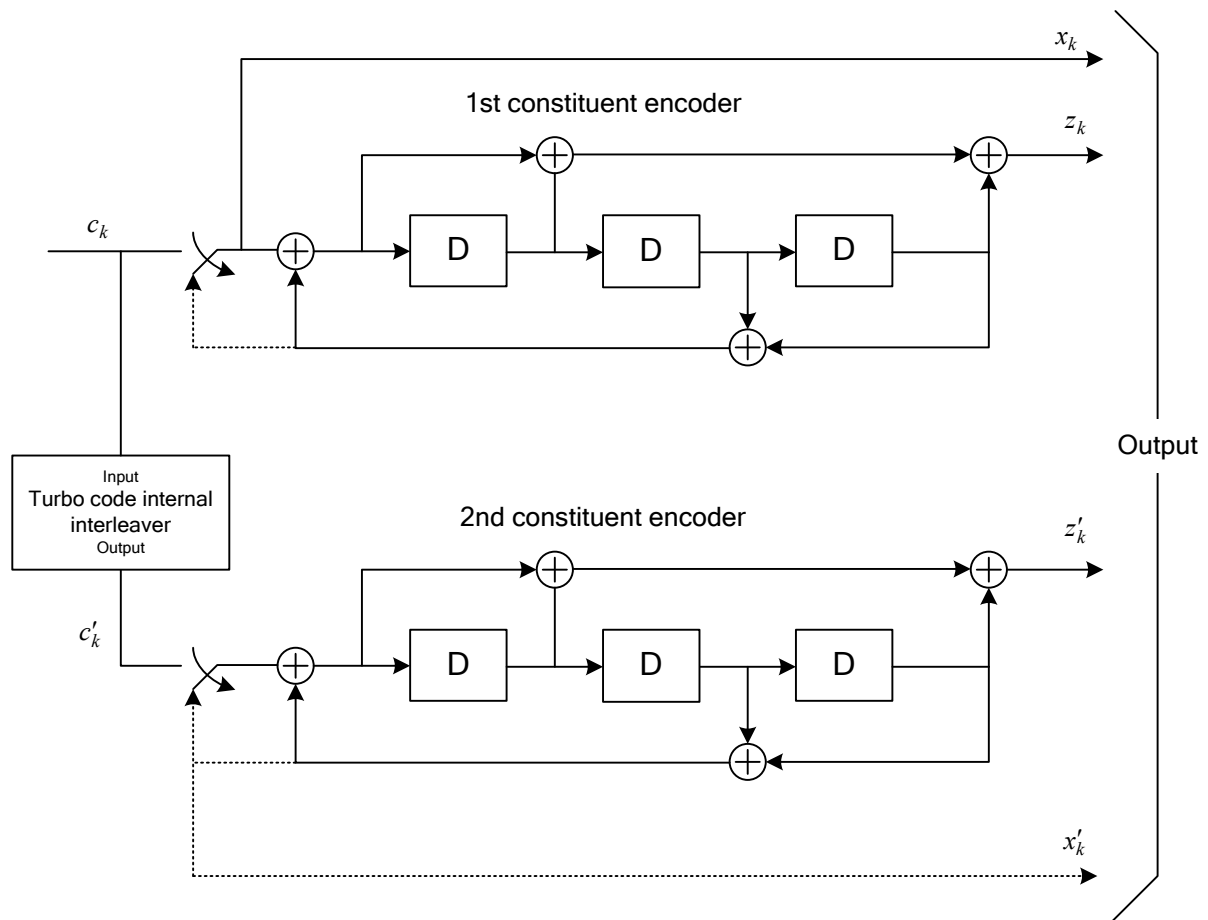

**Figure 5.1.3-2: Structure of rate 1/3 turbo encoder (dotted lines apply for trellis termination only).**

#### 5.1.3.2.2 Trellis termination for turbo encoder

Trellis termination is performed by taking the tail bits from the shift register feedback after all information bits are encoded. Tail bits are padded after the encoding of information bits.

The first three tail bits shall be used to terminate the first constituent encoder (upper switch of figure 5.1.3-2 in lower position) while the second constituent encoder is disabled. The last three tail bits shall be used to terminate the second constituent encoder (lower switch of figure 5.1.3-2 in lower position) while the first constituent encoder is disabled.

The transmitted bits for trellis termination shall then be:

$$d_K^{(0)} = x_K, d_{K+1}^{(0)} = z_{K+1}, d_{K+2}^{(0)} = x'_K, d_{K+3}^{(0)} = z'_{K+1}$$

$$d_K^{(1)} = z_K, d_{K+1}^{(1)} = x_{K+2}, d_{K+2}^{(1)} = z'_K, d_{K+3}^{(1)} = x'_{K+2}$$

$$d_K^{(2)} = x_{K+1}, d_{K+1}^{(2)} = z_{K+2}, d_{K+2}^{(2)} = x'_{K+1}, d_{K+3}^{(2)} = z'_{K+2}$$

#### 5.1.3.2.3 Turbo code internal interleaver

The bits input to the turbo code internal interleaver are denoted by  $c_0, c_1, \dots, c_{K-1}$ , where  $K$  is the number of input bits. The bits output from the turbo code internal interleaver are denoted by  $c'_0, c'_1, \dots, c'_{K-1}$ .

The relationship between the input and output bits is as follows:

$$c'_i = c_{\Pi(i)}, i=0, 1, \dots, (K-1)$$

where the relationship between the output index  $i$  and the input index  $\Pi(i)$  satisfies the following quadratic form:

$$\Pi(i) = (f_1 \cdot i + f_2 \cdot i^2) \bmod K$$

The parameters  $f_1$  and  $f_2$  depend on the block size  $K$  and are summarized in Table 5.1.3-3.

**Table 5.1.3-3: Turbo code internal interleaver parameters.**

$i$	$K$	$f_1$	$f_2$	$i$	$K$	$f_1$	$f_2$	$i$	$K$	$f_1$	$f_2$	$i$	$K$	$f_1$	$f_2$
1	40	3	10	48	416	25	52	95	1120	67	140	142	3200	111	240
2	48	7	12	49	424	51	106	96	1152	35	72	143	3264	443	204
3	56	19	42	50	432	47	72	97	1184	19	74	144	3328	51	104
4	64	7	16	51	440	91	110	98	1216	39	76	145	3392	51	212
5	72	7	18	52	448	29	168	99	1248	19	78	146	3456	451	192
6	80	11	20	53	456	29	114	100	1280	199	240	147	3520	257	220
7	88	5	22	54	464	247	58	101	1312	21	82	148	3584	57	336
8	96	11	24	55	472	29	118	102	1344	211	252	149	3648	313	228
9	104	7	26	56	480	89	180	103	1376	21	86	150	3712	271	232
10	112	41	84	57	488	91	122	104	1408	43	88	151	3776	179	236
11	120	103	90	58	496	157	62	105	1440	149	60	152	3840	331	120
12	128	15	32	59	504	55	84	106	1472	45	92	153	3904	363	244
13	136	9	34	60	512	31	64	107	1504	49	846	154	3968	375	248
14	144	17	108	61	528	17	66	108	1536	71	48	155	4032	127	168
15	152	9	38	62	544	35	68	109	1568	13	28	156	4096	31	64
16	160	21	120	63	560	227	420	110	1600	17	80	157	4160	33	130
17	168	101	84	64	576	65	96	111	1632	25	102	158	4224	43	264
18	176	21	44	65	592	19	74	112	1664	183	104	159	4288	33	134
19	184	57	46	66	608	37	76	113	1696	55	954	160	4352	477	408
20	192	23	48	67	624	41	234	114	1728	127	96	161	4416	35	138
21	200	13	50	68	640	39	80	115	1760	27	110	162	4480	233	280
22	208	27	52	69	656	185	82	116	1792	29	112	163	4544	357	142
23	216	11	36	70	672	43	252	117	1824	29	114	164	4608	337	480
24	224	27	56	71	688	21	86	118	1856	57	116	165	4672	37	146
25	232	85	58	72	704	155	44	119	1888	45	354	166	4736	71	444
26	240	29	60	73	720	79	120	120	1920	31	120	167	4800	71	120
27	248	33	62	74	736	139	92	121	1952	59	610	168	4864	37	152
28	256	15	32	75	752	23	94	122	1984	185	124	169	4928	39	462
29	264	17	198	76	768	217	48	123	2016	113	420	170	4992	127	234
30	272	33	68	77	784	25	98	124	2048	31	64	171	5056	39	158
31	280	103	210	78	800	17	80	125	2112	17	66	172	5120	39	80
32	288	19	36	79	816	127	102	126	2176	171	136	173	5184	31	96
33	296	19	74	80	832	25	52	127	2240	209	420	174	5248	113	902
34	304	37	76	81	848	239	106	128	2304	253	216	175	5312	41	166
35	312	19	78	82	864	17	48	129	2368	367	444	176	5376	251	336
36	320	21	120	83	880	137	110	130	2432	265	456	177	5440	43	170
37	328	21	82	84	896	215	112	131	2496	181	468	178	5504	21	86
38	336	115	84	85	912	29	114	132	2560	39	80	179	5568	43	174
39	344	193	86	86	928	15	58	133	2624	27	164	180	5632	45	176
40	352	21	44	87	944	147	118	134	2688	127	504	181	5696	45	178
41	360	133	90	88	960	29	60	135	2752	143	172	182	5760	161	120
42	368	81	46	89	976	59	122	136	2816	43	88	183	5824	89	182
43	376	45	94	90	992	65	124	137	2880	29	300	184	5888	323	184
44	384	23	48	91	1008	55	84	138	2944	45	92	185	5952	47	186
45	392	243	98	92	1024	31	64	139	3008	157	188	186	6016	23	94
46	400	151	40	93	1056	17	66	140	3072	47	96	187	6080	47	190
47	408	155	102	94	1088	171	204	141	3136	13	28	188	6144	263	480

## 5.1.4 Rate matching

### 5.1.4.1 Rate matching for turbo coded transport channels

The rate matching for turbo coded transport channels is defined per coded block and consists of interleaving the three information bit streams  $d_k^{(0)}$ ,  $d_k^{(1)}$  and  $d_k^{(2)}$ , followed by the collection of bits and the generation of a circular buffer as depicted in Figure 5.1.4-1. The output bits for each code block are transmitted as described in section 5.1.4.1.2.

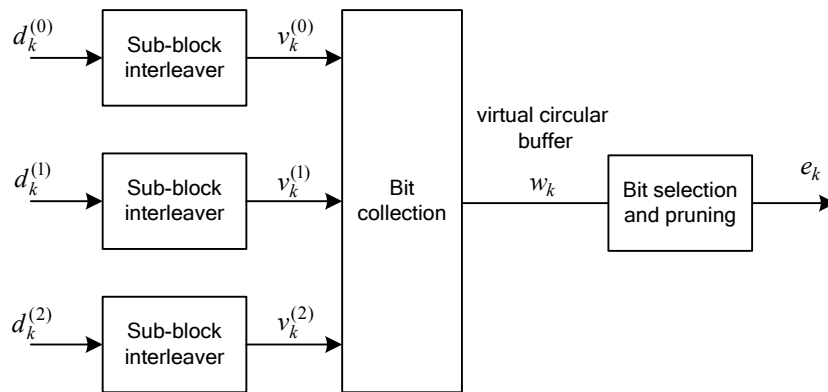

**Figure 5.1.4-1. Rate matching for turbo coded transport channels.**

The bit stream  $d_k^{(0)}$  is interleaved according to the sub-block interleaver defined in section 5.1.4.1.1 with an output sequence defined as  $v_0^{(0)}, v_1^{(0)}, v_2^{(0)}, \dots, v_{K_{\Pi}-1}^{(0)}$  and where  $K_{\Pi}$  is defined in section 5.1.4.1.1.

The bit stream  $d_k^{(1)}$  is interleaved according to the sub-block interleaver defined in section 5.1.4.1.1 with an output sequence defined as  $v_0^{(1)}, v_1^{(1)}, v_2^{(1)}, \dots, v_{K_{\Pi}-1}^{(1)}$ .

The bit stream  $d_k^{(2)}$  is interleaved according to the sub-block interleaver defined in section 5.1.4.1.1 with an output sequence defined as  $v_0^{(2)}, v_1^{(2)}, v_2^{(2)}, \dots, v_{K_{\Pi}-1}^{(2)}$ .

The sequence of bits  $e_k$  for transmission is generated according to section 5.1.4.1.2.

#### 5.1.4.1.1 Sub-block interleaver

The bits input to the block interleaver are denoted by  $d_0^{(i)}, d_1^{(i)}, d_2^{(i)}, \dots, d_{D-1}^{(i)}$ , where  $D$  is the number of bits. The output bit sequence from the block interleaver is derived as follows:

- (1) Assign  $C_{subblock}^{TC} = 32$  to be the number of columns of the matrix. The columns of the matrix are numbered 0, 1, 2, ...,  $C_{subblock}^{TC} - 1$  from left to right.
- (2) Determine the number of rows of the matrix  $R_{subblock}^{TC}$ , by finding minimum integer  $R_{subblock}^{TC}$  such that:

$$D \leq (R_{subblock}^{TC} \times C_{subblock}^{TC})$$

The rows of rectangular matrix are numbered 0, 1, 2, ...,  $R_{subblock}^{TC} - 1$  from top to bottom.



- (3) If  $(R_{subblock}^{TC} \times C_{subblock}^{TC}) > D$ , then  $N_D = (R_{subblock}^{TC} \times C_{subblock}^{TC} - D)$  dummy bits are padded such that  $y_k = \langle NULL \rangle$  for  $k = 0, 1, \dots, N_D - 1$ . Then,  $y_{N_D+k} = d_k^{(i)}$ ,  $k = 0, 1, \dots, D-1$ , and the bit sequence  $y_k$  is written into the  $(R_{subblock}^{TC} \times C_{subblock}^{TC})$  matrix row by row starting with bit  $y_0$  in column 0 of row 0:

$$\begin{bmatrix} y_0 & y_1 & y_2 & \cdots & y_{C_{subblock}^{TC}-1} \\ y_{C_{subblock}^{TC}} & y_{C_{subblock}^{TC}+1} & y_{C_{subblock}^{TC}+2} & \cdots & y_{2C_{subblock}^{TC}-1} \\ \vdots & \vdots & \vdots & \ddots & \vdots \\ y_{(R_{subblock}^{TC}-1) \times C_{subblock}^{TC}} & y_{(R_{subblock}^{TC}-1) \times C_{subblock}^{TC}+1} & y_{(R_{subblock}^{TC}-1) \times C_{subblock}^{TC}+2} & \cdots & y_{(R_{subblock}^{TC} \times C_{subblock}^{TC}-1)} \end{bmatrix}$$

For  $d_k^{(0)}$  and  $d_k^{(1)}$ :

- (4) Perform the inter-column permutation for the matrix based on the pattern  $\langle P(j) \rangle_{j \in \{0, 1, \dots, C_{subblock}^{TC}-1\}}$  that is shown in table 5.1.4-1, where  $P(j)$  is the original column position of the  $j$ -th permuted column. After permutation of the columns, the inter-column permuted  $(R_{subblock}^{TC} \times C_{subblock}^{TC})$  matrix is equal to

$$\begin{bmatrix} y_{P(0)} & y_{P(1)} & y_{P(2)} & \cdots & y_{P(C_{subblock}^{TC}-1)} \\ y_{P(0)+C_{subblock}^{TC}} & y_{P(1)+C_{subblock}^{TC}} & y_{P(2)+C_{subblock}^{TC}} & \cdots & y_{P(C_{subblock}^{TC}-1)+C_{subblock}^{TC}} \\ \vdots & \vdots & \vdots & \ddots & \vdots \\ y_{P(0)+(R_{subblock}^{TC}-1) \times C_{subblock}^{TC}} & y_{P(1)+(R_{subblock}^{TC}-1) \times C_{subblock}^{TC}} & y_{P(2)+(R_{subblock}^{TC}-1) \times C_{subblock}^{TC}} & \cdots & y_{P(C_{subblock}^{TC}-1)+(R_{subblock}^{TC}-1) \times C_{subblock}^{TC}} \end{bmatrix}$$

- (5) The output of the block interleaver is the bit sequence read out column by column from the inter-column permuted  $(R_{subblock}^{TC} \times C_{subblock}^{TC})$  matrix. The bits after sub-block interleaving are denoted by  $v_0^{(i)}, v_1^{(i)}, v_2^{(i)}, \dots, v_{K_{\Pi}-1}^{(i)}$ , where  $v_0^{(i)}$  corresponds to  $y_{P(0)}$ ,  $v_1^{(i)}$  to  $y_{P(0)+C_{subblock}^{TC}}$  ... and  $K_{\Pi} = (R_{subblock}^{TC} \times C_{subblock}^{TC})$ .

For  $d_k^{(2)}$ :

- (4) The output of the sub-block interleaver is denoted by  $v_0^{(2)}, v_1^{(2)}, v_2^{(2)}, \dots, v_{K_{\Pi}-1}^{(2)}$ , where  $v_k^{(2)} = y_{\pi(k)}$  and where

$$\pi(k) = \left( P \left( \left\lfloor \frac{k}{R_{subblock}^{TC}} \right\rfloor \right) + C_{subblock}^{TC} \times (k \bmod R_{subblock}^{TC}) + 1 \right) \bmod K_{\Pi}$$

The permutation function  $P$  is defined in Table 5.1.4-1.

**Table 5.1.4-1 Inter-column permutation pattern for sub-block interleaver.**

Number of columns $C_{subblock}^{TC}$	Inter-column permutation pattern $\langle P(0), P(1), \dots, P(C_{subblock}^{TC}-1) \rangle$
32	$\langle 0, 16, 8, 24, 4, 20, 12, 28, 2, 18, 10, 26, 6, 22, 14, 30, 1, 17, 9, 25, 5, 21, 13, 29, 3, 19, 11, 27, 7, 23, 15, 31 \rangle$

#### 5.1.4.1.2 Bit collection, selection and transmission

The circular buffer of length  $K_w = 3K_{\Pi}$  for the  $r$ -th coded block is generated as follows:

$$w_k = v_k^{(0)} \quad \text{for } k = 0, \dots, K_{\Pi} - 1$$

$$w_{K_{\Pi}+2k} = v_k^{(1)} \quad \text{for } k = 0, \dots, K_{\Pi} - 1$$

$$w_{K_{\Pi}+2k+1} = v_k^{(2)} \text{ for } k = 0, \dots, K_{\Pi} - 1$$

Denote the soft buffer size for the transport block by  $N_{IR}$  bits and the soft buffer size for the  $r$ -th code block by  $N_{cb}$  bits. The size  $N_{cb}$  is obtained as follows, where  $C$  is the number of code blocks computed in section 5.1.2:

$$\begin{aligned} - N_{cb} &= \min\left(\left\lfloor \frac{N_{IR}}{C} \right\rfloor, K_w\right) && \text{for DL-SCH and PCH transport channels} \\ - N_{cb} &= K_w && \text{for UL-SCH and MCH transport channels} \end{aligned}$$

where  $N_{IR}$  is equal to:

$$N_{IR} = \left\lfloor \frac{N_{soft}}{K_C \cdot K_{MIMO} \cdot \min(M_{DL\_HARQ}, M_{limit})} \right\rfloor$$

where:

If the UE signals *ue-Category-v1020*, and is configured with transmission mode 9, or is configured with transmission mode 3 or transmission mode 4 and the higher layer parameter *maxLayersMIMO-r10* is configured to fourLayers for the DL cell,  $N_{soft}$  is the total number of soft channel bits [4] according to the UE category indicated by *ue-Category-v1020* [6]. Otherwise,  $N_{soft}$  is the total number of soft channel bits [4] according to the UE category indicated by *ue-Category* [6].

If  $N_{soft} = 35982720$ ,

$$K_C = 5,$$

elseif  $N_{soft} = 3654144$  and the UE is capable of supporting no more than a maximum of two spatial layers for the DL cell,

$$K_C = 2$$

else

$$K_C = 1$$

End if.

$K_{MIMO}$  is equal to 2 if the UE is configured to receive PDSCH transmissions based on transmission modes 3, 4, 8 or 9 as defined in section 7.1 of [3], and is equal to 1 otherwise.

$M_{DL\_HARQ}$  is the maximum number of DL HARQ processes as defined in section 7 of [3].

$M_{limit}$  is a constant equal to 8.

Denoting by  $E$  the rate matching output sequence length for the  $r$ -th coded block, and  $rv_{idx}$  the redundancy version number for this transmission ( $rv_{idx} = 0, 1, 2$  or  $3$ ), the rate matching output bit sequence is  $e_k, k = 0, 1, \dots, E - 1$ .

Define by  $G$  the total number of bits available for the transmission of one transport block.

Set  $G' = G / (N_L \cdot Q_m)$  where  $Q_m$  is equal to 2 for QPSK, 4 for 16QAM and 6 for 64QAM, and where

- For transmit diversity:
  - $N_L$  is equal to 2,
- Otherwise:
  - $N_L$  is equal to the number of layers a transport block is mapped onto

Set  $\gamma = G' \bmod C$ , where  $C$  is the number of code blocks computed in section 5.1.2.

if  $r \leq C - \gamma - 1$

set  $E = N_L \cdot Q_m \cdot \lfloor G' / C \rfloor$

else

set  $E = N_L \cdot Q_m \cdot \lceil G' / C \rceil$

end if

Set  $k_0 = R_{subblock}^{TC} \cdot \left( 2 \cdot \left\lceil \frac{N_{cb}}{8R_{subblock}^{TC}} \right\rceil \cdot rv_{idx} + 2 \right)$ , where  $R_{subblock}^{TC}$  is the number of rows defined in section 5.1.4.1.1.

Set  $k = 0$  and  $j = 0$

while  $\{ k < E \}$

if  $w_{(k_0+j) \bmod N_{cb}} \neq \langle NULL \rangle$

$e_k = w_{(k_0+j) \bmod N_{cb}}$

$k = k + 1$

end if

$j = j + 1$

end while

#### 5.1.4.2 Rate matching for convolutionally coded transport channels and control information

The rate matching for convolutionally coded transport channels and control information consists of interleaving the three bit streams,  $d_k^{(0)}$ ,  $d_k^{(1)}$  and  $d_k^{(2)}$ , followed by the collection of bits and the generation of a circular buffer as depicted in Figure 5.1.4-2. The output bits are transmitted as described in section 5.1.4.2.2.

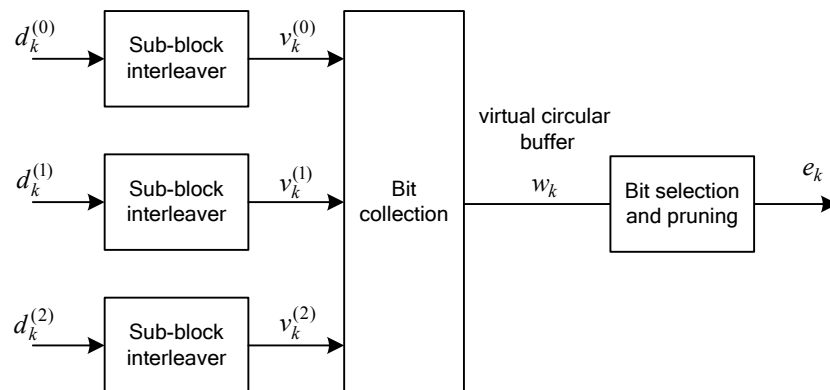

**Figure 5.1.4-2. Rate matching for convolutionally coded transport channels and control information.**

The bit stream  $d_k^{(0)}$  is interleaved according to the sub-block interleaver defined in section 5.1.4.2.1 with an output sequence defined as  $v_0^{(0)}, v_1^{(0)}, v_2^{(0)}, \dots, v_{K_{\Pi}-1}^{(0)}$  and where  $K_{\Pi}$  is defined in section 5.1.4.2.1.

The bit stream  $d_k^{(1)}$  is interleaved according to the sub-block interleaver defined in section 5.1.4.2.1 with an output sequence defined as  $v_0^{(1)}, v_1^{(1)}, v_2^{(1)}, \dots, v_{K_{\Pi}-1}^{(1)}$ .

The bit stream  $d_k^{(2)}$  is interleaved according to the sub-block interleaver defined in section 5.1.4.2.1 with an output sequence defined as  $v_0^{(2)}, v_1^{(2)}, v_2^{(2)}, \dots, v_{K_{\Pi}-1}^{(2)}$ .

The sequence of bits  $e_k$  for transmission is generated according to section 5.1.4.2.2.

### 5.1.4.2.1 Sub-block interleaver

The bits input to the block interleaver are denoted by  $d_0^{(i)}, d_1^{(i)}, d_2^{(i)}, \dots, d_{D-1}^{(i)}$ , where  $D$  is the number of bits. The output bit sequence from the block interleaver is derived as follows:

- (1) Assign  $C_{subblock}^{CC} = 32$  to be the number of columns of the matrix. The columns of the matrix are numbered 0, 1, 2, ...,  $C_{subblock}^{CC} - 1$  from left to right.

- (2) Determine the number of rows of the matrix  $R_{subblock}^{CC}$ , by finding minimum integer  $R_{subblock}^{CC}$  such that:

$$D \leq (R_{subblock}^{CC} \times C_{subblock}^{CC})$$

The rows of rectangular matrix are numbered 0, 1, 2, ...,  $R_{subblock}^{CC} - 1$  from top to bottom.

- (3) If  $(R_{subblock}^{CC} \times C_{subblock}^{CC}) > D$ , then  $N_D = (R_{subblock}^{CC} \times C_{subblock}^{CC} - D)$  dummy bits are padded such that  $y_k = \langle NULL \rangle$  for  $k = 0, 1, \dots, N_D - 1$ . Then,  $y_{N_D+k} = d_k^{(i)}$ ,  $k = 0, 1, \dots, D-1$ , and the bit sequence  $y_k$  is written into the  $(R_{subblock}^{CC} \times C_{subblock}^{CC})$  matrix row by row starting with bit  $y_0$  in column 0 of row 0:

$$\begin{bmatrix} y_0 & y_1 & y_2 & \dots & y_{C_{subblock}^{CC}-1} \\ y_{C_{subblock}^{CC}} & y_{C_{subblock}^{CC}+1} & y_{C_{subblock}^{CC}+2} & \dots & y_{2C_{subblock}^{CC}-1} \\ \vdots & \vdots & \vdots & \ddots & \vdots \\ y_{(R_{subblock}^{CC}-1) \times C_{subblock}^{CC}} & y_{(R_{subblock}^{CC}-1) \times C_{subblock}^{CC}+1} & y_{(R_{subblock}^{CC}-1) \times C_{subblock}^{CC}+2} & \dots & y_{(R_{subblock}^{CC}-1) \times C_{subblock}^{CC}-1} \end{bmatrix}$$

- (4) Perform the inter-column permutation for the matrix based on the pattern  $\langle P(j) \rangle_{j \in \{0, 1, \dots, C_{subblock}^{CC}-1\}}$  that is shown in table 5.1.4-2, where  $P(j)$  is the original column position of the  $j$ -th permuted column. After permutation of the columns, the inter-column permuted  $(R_{subblock}^{CC} \times C_{subblock}^{CC})$  matrix is equal to

$$\begin{bmatrix} y_{P(0)} & y_{P(1)} & y_{P(2)} & \dots & y_{P(C_{subblock}^{CC}-1)} \\ y_{P(0)+C_{subblock}^{CC}} & y_{P(1)+C_{subblock}^{CC}} & y_{P(2)+C_{subblock}^{CC}} & \dots & y_{P(C_{subblock}^{CC}-1)+C_{subblock}^{CC}} \\ \vdots & \vdots & \vdots & \ddots & \vdots \\ y_{P(0)+(R_{subblock}^{CC}-1) \times C_{subblock}^{CC}} & y_{P(1)+(R_{subblock}^{CC}-1) \times C_{subblock}^{CC}} & y_{P(2)+(R_{subblock}^{CC}-1) \times C_{subblock}^{CC}} & \dots & y_{P(C_{subblock}^{CC}-1)+(R_{subblock}^{CC}-1) \times C_{subblock}^{CC}} \end{bmatrix}$$

- (5) The output of the block interleaver is the bit sequence read out column by column from the inter-column permuted  $(R_{subblock}^{CC} \times C_{subblock}^{CC})$  matrix. The bits after sub-block interleaving are denoted by  $v_0^{(i)}, v_1^{(i)}, v_2^{(i)}, \dots, v_{K_{\Pi}-1}^{(i)}$ , where  $v_0^{(i)}$  corresponds to  $y_{P(0)}$ ,  $v_1^{(i)}$  to  $y_{P(0)+C_{subblock}^{CC}}$  ... and  $K_{\Pi} = (R_{subblock}^{CC} \times C_{subblock}^{CC})$

**Table 5.1.4-2 Inter-column permutation pattern for sub-block interleaver.**

Number of columns $C_{subblock}^{CC}$	Inter-column permutation pattern $\langle P(0), P(1), \dots, P(C_{subblock}^{CC}-1) \rangle$
32	$\langle 1, 17, 9, 25, 5, 21, 13, 29, 3, 19, 11, 27, 7, 23, 15, 31, 0, 16, 8, 24, 4, 20, 12, 28, 2, 18, 10, 26, 6, 22, 14, 30 \rangle$

This block interleaver is also used in interleaving PDCCH modulation symbols. In that case, the input bit sequence consists of PDCCH symbol quadruplets [2].

#### 5.1.4.2.2 Bit collection, selection and transmission

The circular buffer of length  $K_w = 3K_{\Pi}$  is generated as follows:

$$w_k = v_k^{(0)} \quad \text{for } k = 0, \dots, K_{\Pi} - 1$$

$$w_{K_{\Pi}+k} = v_k^{(1)} \quad \text{for } k = 0, \dots, K_{\Pi} - 1$$

$$w_{2K_{\Pi}+k} = v_k^{(2)} \quad \text{for } k = 0, \dots, K_{\Pi} - 1$$

Denoting by  $E$  the rate matching output sequence length, the rate matching output bit sequence is  $e_k, k = 0, 1, \dots, E - 1$ .

Set  $k = 0$  and  $j = 0$

while  $\{ k < E \}$

if  $w_{j \bmod K_w} \neq \text{NULL}$

$$e_k = w_{j \bmod K_w}$$

$$k = k + 1$$

end if

$$j = j + 1$$

end while

### 5.1.5 Code block concatenation

The input bit sequence for the code block concatenation block are the sequences  $e_{rk}$ , for  $r = 0, \dots, C - 1$  and  $k = 0, \dots, E_r - 1$ . The output bit sequence from the code block concatenation block is the sequence  $f_k$  for  $k = 0, \dots, G - 1$ .

The code block concatenation consists of sequentially concatenating the rate matching outputs for the different code blocks. Therefore,

Set  $k = 0$  and  $r = 0$

while  $r < C$

Set  $j = 0$

while  $j < E_r$

$$f_k = e_{rj}$$

$$k = k + 1$$

$$j = j + 1$$

end while

$$r = r + 1$$

end while

## 5.2 Uplink transport channels and control information

### 5.2.1 Random access channel

The sequence index for the random access channel is received from higher layers and is processed according to [2].

### 5.2.2 Uplink shared channel

Figure 5.2.2-1 shows the processing structure for the UL-SCH transport channel on one UL cell. Data arrives to the coding unit in the form of a maximum of two transport blocks every transmission time interval (TTI) per UL cell. The following coding steps can be identified for each transport block of an UL cell:

- Add CRC to the transport block
- Code block segmentation and code block CRC attachment
- Channel coding of data and control information
- Rate matching
- Code block concatenation
- Multiplexing of data and control information
- Channel interleaver

The coding steps for one UL-SCH transport block are shown in the figure below. The same general processing applies for each UL-SCH transport block on each UL cell with restrictions as specified in [3].

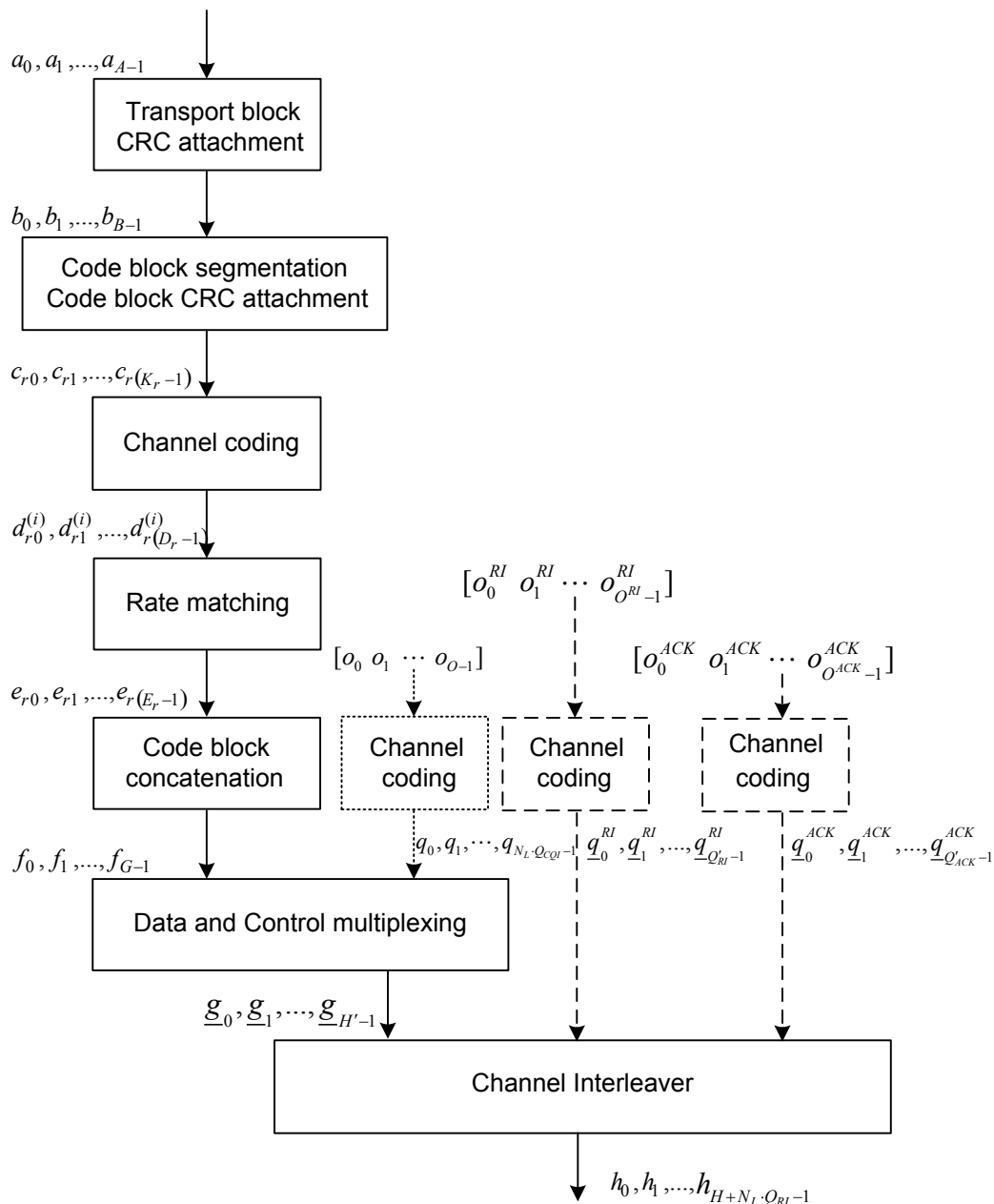

Figure 5.2.2-1: Transport block processing for UL-SCH.

### 5.2.2.1 Transport block CRC attachment

Error detection is provided on each UL-SCH transport block through a Cyclic Redundancy Check (CRC).

The entire transport block is used to calculate the CRC parity bits. Denote the bits in a transport block delivered to layer 1 by  $a_0, a_1, a_2, a_3, \dots, a_{A-1}$ , and the parity bits by  $p_0, p_1, p_2, p_3, \dots, p_{L-1}$ .  $A$  is the size of the transport block and  $L$  is the number of parity bits. The lowest order information bit  $a_0$  is mapped to the most significant bit of the transport block as defined in section 6.1.1 of [5].

The parity bits are computed and attached to the UL-SCH transport block according to section 5.1.1 setting  $L$  to 24 bits and using the generator polynomial  $g_{\text{CRC24A}}(D)$ .

### 5.2.2.2 Code block segmentation and code block CRC attachment

The bits input to the code block segmentation are denoted by  $b_0, b_1, b_2, b_3, \dots, b_{B-1}$  where  $B$  is the number of bits in the transport block (including CRC).

Code block segmentation and code block CRC attachment are performed according to section 5.1.2.

The bits after code block segmentation are denoted by  $c_{r0}, c_{r1}, c_{r2}, c_{r3}, \dots, c_{r(K_r-1)}$ , where  $r$  is the code block number and  $K_r$  is the number of bits for code block number  $r$ .

### 5.2.2.3 Channel coding of UL-SCH

Code blocks are delivered to the channel coding block. The bits in a code block are denoted by  $c_{r0}, c_{r1}, c_{r2}, c_{r3}, \dots, c_{r(K_r-1)}$ , where  $r$  is the code block number, and  $K_r$  is the number of bits in code block number  $r$ . The total number of code blocks is denoted by  $C$  and each code block is individually turbo encoded according to section 5.1.3.2.

After encoding the bits are denoted by  $d_{r0}^{(i)}, d_{r1}^{(i)}, d_{r2}^{(i)}, d_{r3}^{(i)}, \dots, d_{r(D_r-1)}^{(i)}$ , with  $i = 0, 1, \text{ and } 2$  and where  $D_r$  is the number of bits on the  $i$ -th coded stream for code block number  $r$ , i.e.  $D_r = K_r + 4$ .

### 5.2.2.4 Rate matching

Turbo coded blocks are delivered to the rate matching block. They are denoted by  $d_{r0}^{(i)}, d_{r1}^{(i)}, d_{r2}^{(i)}, d_{r3}^{(i)}, \dots, d_{r(D_r-1)}^{(i)}$ , with  $i = 0, 1, \text{ and } 2$ , and where  $r$  is the code block number,  $i$  is the coded stream index, and  $D_r$  is the number of bits in each coded stream of code block number  $r$ . The total number of code blocks is denoted by  $C$  and each coded block is individually rate matched according to section 5.1.4.1.

After rate matching, the bits are denoted by  $e_{r0}, e_{r1}, e_{r2}, e_{r3}, \dots, e_{r(E_r-1)}$ , where  $r$  is the coded block number, and where  $E_r$  is the number of rate matched bits for code block number  $r$ .

### 5.2.2.5 Code block concatenation

The bits input to the code block concatenation block are denoted by  $e_{r0}, e_{r1}, e_{r2}, e_{r3}, \dots, e_{r(E_r-1)}$  for  $r = 0, \dots, C-1$  and where  $E_r$  is the number of rate matched bits for the  $r$ -th code block.

Code block concatenation is performed according to section 5.1.5.

The bits after code block concatenation are denoted by  $f_0, f_1, f_2, f_3, \dots, f_{G-1}$ , where  $G$  is the total number of coded bits for transmission of the given transport block over  $N_L$  transmission layers excluding the bits used for control transmission, when control information is multiplexed with the UL-SCH transmission.

### 5.2.2.6 Channel coding of control information

Control data arrives at the coding unit in the form of channel quality information (CQI and/or PMI), HARQ-ACK and rank indication. Different coding rates for the control information are achieved by allocating different number of coded symbols for its transmission. When control data are transmitted in the PUSCH, the channel coding for HARQ-ACK, rank indication and channel quality information  $o_0, o_1, o_2, \dots, o_{O-1}$  is done independently.

For TDD, the number of HARQ-ACK bits is determined as described in section 7.3 of [3].

When the UE transmits HARQ-ACK bits or rank indicator bits, it shall determine the number of coded modulation symbols per layer  $Q'$  for HARQ-ACK or rank indicator as follows.

For the case when only one transport block is transmitted in the PUSCH conveying the HARQ-ACK bits or rank indicator bits:



$$Q' = \min \left( \left[ \frac{O \cdot M_{sc}^{PUSCH-initial} \cdot N_{symb}^{PUSCH-initial} \cdot \beta_{offset}^{PUSCH}}{\sum_{r=0}^{C-1} K_r} \right], 4 \cdot M_{sc}^{PUSCH} \right)$$

where  $O$  is the number of HARQ-ACK bits or rank indicator bits,  $M_{sc}^{PUSCH}$  is the scheduled bandwidth for PUSCH transmission in the current sub-frame for the transport block, expressed as a number of subcarriers in [2], and  $N_{symb}^{PUSCH-initial}$  is the number of SC-FDMA symbols per subframe for initial PUSCH transmission for the same transport block, respectively, given by  $N_{symb}^{PUSCH-initial} = (2 \cdot (N_{symb}^{UL} - 1) - N_{SRS})$ , where  $N_{SRS}$  is equal to 1 if UE transmits PUSCH and SRS in the same subframe for initial transmission, or if the PUSCH resource allocation for initial transmission even partially overlaps with the cell-specific SRS subframe and bandwidth configuration defined in section 5.5.3 of [2], or if the subframe for initial transmission is a UE-specific type-1 SRS subframe as defined in Section 8.2 of [3]. Otherwise  $N_{SRS}$  is equal to 0.  $M_{sc}^{PUSCH-initial}$ ,  $C$ , and  $K_r$  are obtained from the initial PDCCH for the same transport block. If there is no initial PDCCH with DCI format 0 for the same transport block,  $M_{sc}^{PUSCH-initial}$ ,  $C$ , and  $K_r$  shall be determined from:

- the most recent semi-persistent scheduling assignment PDCCH, when the initial PUSCH for the same transport block is semi-persistently scheduled, or,
- the random access response grant for the same transport block, when the PUSCH is initiated by the random access response grant.

For the case when two transport blocks are transmitted in the PUSCH conveying the HARQ-ACK bits or rank indicator bits:

$$Q' = \max \left[ \min(Q'_{temp}, 4 \cdot M_{sc}^{PUSCH}), Q'_{min} \right] \text{ with}$$

$$Q'_{temp} = \left[ \frac{O \cdot M_{sc}^{PUSCH-initial(1)} \cdot N_{symb}^{PUSCH-initial(1)} \cdot M_{sc}^{PUSCH-initial(2)} \cdot N_{symb}^{PUSCH-initial(2)} \cdot \beta_{offset}^{PUSCH}}{\sum_{r=0}^{C^{(1)}-1} K_r^{(1)} \cdot M_{sc}^{PUSCH-initial(2)} \cdot N_{symb}^{PUSCH-initial(2)} + \sum_{r=0}^{C^{(2)}-1} K_r^{(2)} \cdot M_{sc}^{PUSCH-initial(1)} \cdot N_{symb}^{PUSCH-initial(1)}} \right]$$

where  $O$  is the number of HARQ-ACK bits or rank indicator bits,  $Q'_{min} = O$  if  $O \leq 2$ ,  $Q'_{min} = \lceil 2O / Q'_m \rceil$  if  $3 \leq O \leq 11$  with  $Q'_m = \min(Q'_m^1, Q'_m^2)$  where  $Q'_m^x, x = \{1,2\}$  is the modulation order of transport block "x", and  $Q'_{min} = \lceil 2O_1 / Q'_m \rceil + \lceil 2O_2 / Q'_m \rceil$  if  $O > 11$  with  $O_1 = \lceil O / 2 \rceil$  and  $O_2 = O - \lceil O / 2 \rceil$ .  $M_{sc}^{PUSCH-initial(x)}, x = \{1,2\}$  are the scheduled bandwidths for PUSCH transmission in the initial sub-frame for the first and second transport block, respectively, expressed as a number of subcarriers in [2], and  $N_{symb}^{PUSCH-initial(x)}, x = \{1,2\}$  are the number of SC-FDMA symbols per subframe for initial PUSCH transmission for the first and second transport block given by  $N_{symb}^{PUSCH-initial(x)} = (2 \cdot (N_{symb}^{UL} - 1) - N_{SRS}^{(x)})$ ,  $x = \{1,2\}$ , where  $N_{SRS}^{(x)}, x = \{1,2\}$  is equal to 1 if UE transmits PUSCH and SRS in the same subframe for initial transmission of transport block "x", or if the PUSCH resource allocation for initial transmission of transport block "x" even partially overlaps with the cell-specific SRS subframe and bandwidth configuration defined in section 5.5.3 of [2], or if the subframe for initial transmission of transport block "x" is a UE-specific type-1 SRS subframe as defined in Section 8.2 of [3]. Otherwise  $N_{SRS}^{(x)}, x = \{1,2\}$  is equal to 0.  $M_{sc}^{PUSCH-initial(x)}, x = \{1,2\}$ ,  $C^{(x)}, x = \{1,2\}$ , and  $K_r^{(x)}, x = \{1,2\}$  are obtained from the initial PDCCH for the corresponding transport block.

For HARQ-ACK,  $Q_{ACK} = Q'_m \cdot Q'$  and  $\beta_{offset}^{PUSCH} = \beta_{offset}^{HARQ-ACK}$ , where  $Q'_m$  is the modulation order of a given transport block, and  $\beta_{offset}^{HARQ-ACK}$  shall be determined according to [3] depending on the number of transmission codewords for the corresponding PUSCH.

For rank indication,  $Q_{RI} = Q_m \cdot Q'$  and  $\beta_{offset}^{PUSCH} = \beta_{offset}^{RI}$ , where  $Q_m$  is the modulation order of a given transport block, and  $\beta_{offset}^{RI}$  shall be determined according to [3] depending on the number of transmission codewords for the corresponding PUSCH.

For HARQ-ACK

- Each positive acknowledgement (ACK) is encoded as a binary ‘1’ and each negative acknowledgement (NACK) is encoded as a binary ‘0’
- If HARQ-ACK feedback consists of 1-bit of information, i.e.,  $[o_0^{ACK}]$ , it is first encoded according to Table 5.2.2.6-1.
- If HARQ-ACK feedback consists of 2-bits of information, i.e.,  $[o_0^{ACK} o_1^{ACK}]$  with  $o_0^{ACK}$  corresponding to HARQ-ACK bit for codeword 0 and  $o_1^{ACK}$  corresponding to that for codeword 1, or if HARQ-ACK feedback consists of 2-bits of information as a result of the aggregation of HARQ-ACK bits corresponding to two DL cells with which the UE is configured by higher layers, or if HARQ-ACK feedback consists of 2-bits of information corresponding to two DL subframes for TDD, it is first encoded according to Table 5.2.2.6-2 where  $o_2^{ACK} = (o_0^{ACK} + o_1^{ACK}) \bmod 2$ .

**Table 5.2.2.6-1: Encoding of 1-bit HARQ-ACK.**

$Q_m$	Encoded HARQ-ACK
2	$[o_0^{ACK} y]$
4	$[o_0^{ACK} y x x]$
6	$[o_0^{ACK} y x x x x]$

**Table 5.2.2.6-2: Encoding of 2-bit HARQ-ACK.**

$Q_m$	Encoded HARQ-ACK
2	$[o_0^{ACK} o_1^{ACK} o_2^{ACK} o_0^{ACK} o_1^{ACK} o_2^{ACK}]$
4	$[o_0^{ACK} o_1^{ACK} x x o_2^{ACK} o_0^{ACK} x x o_1^{ACK} o_2^{ACK} x x]$
6	$[o_0^{ACK} o_1^{ACK} x x x x o_2^{ACK} o_0^{ACK} x x x x o_1^{ACK} o_2^{ACK} x x x x]$

- If HARQ-ACK feedback consists of  $3 \leq O^{ACK} \leq 11$  bits of information as a result of the aggregation of HARQ-ACK bits corresponding to one or more DL cells with which the UE is configured by higher layers, i.e.,  $o_0^{ACK} o_1^{ACK} \dots, o_{O^{ACK}-1}^{ACK}$ , then a coded bit sequence  $\tilde{q}_0^{ACK} \tilde{q}_1^{ACK} \dots, \tilde{q}_{31}^{ACK}$  is obtained by using the bit sequence  $o_0^{ACK} o_1^{ACK} \dots, o_{O^{ACK}-1}^{ACK}$  as the input to the channel coding block described in section 5.2.2.6.4. In turn, the bit sequence  $q_0^{ACK}, q_1^{ACK}, q_2^{ACK}, \dots, q_{Q_{ACK}-1}^{ACK}$  is obtained by the circular repetition of the bit sequence  $\tilde{q}_0^{ACK} \tilde{q}_1^{ACK} \dots, \tilde{q}_{31}^{ACK}$  so that the total bit sequence length is equal to  $Q_{ACK}$ .
- If HARQ-ACK feedback consists of  $11 < O^{ACK} \leq 20$  bits of information as a result of the aggregation of HARQ-ACK bits corresponding to one or more DL cells with which the UE is configured by higher layers, i.e.,  $o_0^{ACK} o_1^{ACK} \dots, o_{O^{ACK}-1}^{ACK}$ , then the coded bit sequence  $q_0^{ACK}, q_1^{ACK}, q_2^{ACK}, \dots, q_{Q_{ACK}-1}^{ACK}$  is obtained by using the bit sequence  $o_0^{ACK} o_1^{ACK} \dots, o_{O^{ACK}-1}^{ACK}$  as the input to the channel coding block described in section 5.2.2.6.5.

The ‘x’ and ‘y’ in Table 5.2.2.6-1 and 5.2.2.6-2 are placeholders for [2] to scramble the HARQ-ACK bits in a way that maximizes the Euclidean distance of the modulation symbols carrying HARQ-ACK information.

For FDD or TDD HARQ-ACK multiplexing when HARQ-ACK consists of one or two bits of information, the bit sequence  $q_0^{ACK}, q_1^{ACK}, q_2^{ACK}, \dots, q_{Q_{ACK}-1}^{ACK}$  is obtained by concatenation of multiple encoded HARQ-ACK blocks where  $Q_{ACK}$  is the total number of coded bits for all the encoded HARQ-ACK blocks. The last concatenation of the encoded HARQ-ACK block may be partial so that the total bit sequence length is equal to  $Q_{ACK}$ .

For FDD when HARQ ACK consists of 2 or more bits of information as a result of the aggregation of more than one DL cell, the bit sequence  $o_0^{ACK}, o_1^{ACK}, \dots, o_{O_{ACK}-1}^{ACK}$  is the result of the concatenation of HARQ-ACK bits for the multiple DL cells according to the following pseudo-code:

Set  $c = 0$  – cell index: lower indices correspond to lower RRC indices of corresponding cell

Set  $j = 0$  – HARQ-ACK bit index

Set  $N_{cells}^{DL}$  to the number of cells configured by higher layers for the UE

while  $c < N_{cells}^{DL}$

if transmission mode configured in cell  $c \in \{1,2,5,6,7\}$  – 1 bit HARQ-ACK feedback for this cell

$o_j^{ACK} =$  HARQ-ACK bit of this cell

$j = j + 1$

else

$o_j^{ACK} =$  HARQ-ACK bit corresponding to the first codeword of this cell

$j = j + 1$

$o_j^{ACK} =$  HARQ-ACK bit corresponding to the second codeword of this cell

$j = j + 1$

end if

$c = c + 1$

end while

For TDD when HARQ ACK is for the aggregation of one or more DL cells and the UE is configured with PUCCH Format 3 [3], the bit sequence  $o_0^{ACK}, o_1^{ACK}, \dots, o_{O_{ACK}-1}^{ACK}$  is the result of the concatenation of HARQ-ACK bits for the one or more DL cells configured by higher layers and the multiple subframes as defined in [3].

Define  $N_{cells}^{DL}$  as the number of cells configured by higher layers for the UE and  $B_c^{DL}$  as the number of downlink subframes for which the UE needs to feedback HARQ-ACK bits as defined in Section 7.3 of [3].

The number of HARQ-ACK bits for the UE to convey if it is configured with PUCCH Format 3 is computed as follows:

Set  $k = 0$  – counter of HARQ-ACK bits

Set  $c=0$  – cell index: lower indices correspond to lower RRC indices of corresponding cell

while  $c < N_{cells}^{DL}$

set  $l = 0$ ;

while  $l < B_c^{DL}$

if transmission mode configured in cell  $c \in \{1,2,5,6,7\}$  -- 1 bit HARQ-ACK feedback for this cell

$k = k + 1$

else

$k = k + 2$

end if

$l = l + 1$

end while

$c = c + 1$

end while

If  $k \leq 20$ , the multiplexing of HARQ-ACK bits is performed according to the following pseudo-code:

Set  $c = 0$  – cell index: lower indices correspond to lower RRC indices of corresponding cell

Set  $j = 0$  – HARQ-ACK bit index

while  $c < N_{cells}^{DL}$

set  $l = 0$ ;

while  $l < B_c^{DL}$

if transmission mode configured in cell  $c \in \{1,2,5,6,7\}$  -- 1 bit HARQ-ACK feedback for this cell

$\tilde{o}_j^{ACK} = o_{c,l}^{ACK}$  HARQ-ACK bit of this cell as defined in Section 7.3 of [3]

$j = j + 1$

else

$[\tilde{o}_j^{ACK}, \tilde{o}_{j+1}^{ACK}] = [o_{c,2l}^{ACK}, o_{c,2l+1}^{ACK}]$  HARQ-ACK bits of this cell as defined in Section 7.3 of [3]

$j = j + 2$

end if

$l = l + 1$

end while

$c = c + 1$

end while

If  $k > 20$ , spatial bundling is applied to all subframes in all cells and the multiplexing of HARQ-ACK bits is performed according to the following pseudo-code

Set  $c = 0$  – cell index: lower indices correspond to lower RRC indices of corresponding cell

Set  $j = 0$  – HARQ-ACK bit index

while  $c < N_{cells}^{DL}$

set  $l = 0$ ;

while  $l < B_c^{DL}$

if transmission mode configured in cell  $c \in \{1,2,5,6,7\}$  – 1 bit HARQ-ACK feedback for this cell

$\tilde{o}_j^{ACK} = o_{c,l}^{ACK}$  HARQ-ACK bit of this cell as defined in Section 7.3 of [3]

$j = j + 1$

else

$\tilde{o}_j^{ACK} = o_{c,l}^{ACK}$  binary AND operation of the HARQ-ACK bits corresponding to the first and second codewords of this cell as defined in Section 7.3 of [3]

$j = j + 1$

end if

$l = l + 1$

end while

$c = c + 1$

end while

For  $o^{ACK} \leq 11$ , the bit sequence  $o_0^{ACK} o_1^{ACK} \dots, o_{o^{ACK}-1}^{ACK}$  is obtained by setting  $o_i^{ACK} = \tilde{o}_i^{ACK}$ .

For  $11 < o^{ACK} \leq 20$ , the bit sequence  $o_0^{ACK} o_1^{ACK} \dots, o_{o^{ACK}-1}^{ACK}$  is obtained by setting  $o_{i/2}^{ACK} = \tilde{o}_i^{ACK}$  if  $i$  is even and  $o_{\lfloor o^{ACK}/2 \rfloor + (i-1)/2}^{ACK} = \tilde{o}_i^{ACK}$  if  $i$  is odd.

For TDD when HARQ ACK is for the aggregation of two DL cells and the UE is configured with PUCCH format 1b with channel selection, the bit sequence  $o_0^{ACK} o_1^{ACK} \dots, o_{o^{ACK}-1}^{ACK}$  is obtained as described in section 7.3 of [3].

For TDD HARQ-ACK bundling, a bit sequence  $\tilde{q}_0^{ACK}, \tilde{q}_1^{ACK}, \tilde{q}_2^{ACK}, \dots, \tilde{q}_{Q_{ACK}-1}^{ACK}$  is obtained by concatenation of multiple encoded HARQ-ACK blocks where  $Q_{ACK}$  is the total number of coded bits for all the encoded HARQ-ACK blocks. The last concatenation of the encoded HARQ-ACK block may be partial so that the total bit sequence length is equal to  $Q_{ACK}$ . A scrambling sequence  $[w_0^{ACK} w_1^{ACK} w_2^{ACK} w_3^{ACK}]$  is then selected from Table 5.2.2.6-A with index  $i = (N_{\text{bundled}} - 1) \bmod 4$ , where  $N_{\text{bundled}}$  is determined as described in section 7.3 of [3]. The bit sequence  $q_0^{ACK}, q_1^{ACK}, q_2^{ACK}, \dots, q_{Q_{ACK}-1}^{ACK}$  is then generated by setting  $m = 1$  if HARQ-ACK consists of 1-bit and  $m = 3$  if HARQ-ACK consists of 2-bits and then scrambling  $\tilde{q}_0^{ACK}, \tilde{q}_1^{ACK}, \tilde{q}_2^{ACK}, \dots, \tilde{q}_{Q_{ACK}-1}^{ACK}$  as follows

Set  $i, k$  to 0

while  $i < Q_{ACK}$

if  $\tilde{q}_i^{ACK} = y$  // place-holder repetition bit

$$q_i^{ACK} = (\tilde{q}_{i-1}^{ACK} + w_{\lfloor k/m \rfloor}^{ACK}) \bmod 2$$

$$k = (k + 1) \bmod 4m$$

else

if  $\tilde{q}_i^{ACK} = x$  // a place-holder bit

$$q_i^{ACK} = \tilde{q}_i^{ACK}$$

else // coded bit

$$q_i^{ACK} = (\tilde{q}_i^{ACK} + w_{\lfloor k/m \rfloor}^{ACK}) \bmod 2$$

$$k = (k + 1) \bmod 4m$$

end if

$$i = i + 1$$

end while

**Table 5.2.2.6-A: Scrambling sequence selection for TDD HARQ-ACK bundling.**

$i$	$[w_0^{ACK} \ w_1^{ACK} \ w_2^{ACK} \ w_3^{ACK}]$
0	[1 1 1 1]
1	[1 0 1 0]
2	[1 1 0 0]
3	[1 0 0 1]

When HARQ-ACK information is to be multiplexed with UL-SCH at a given PUSCH, the HARQ-ACK information is multiplexed in all layers of all transport blocks of that PUSCH, For a given transport block, the vector sequence output of the channel coding for HARQ-ACK information is denoted by  $\underline{q}_0^{ACK}, \underline{q}_1^{ACK}, \dots, \underline{q}_{Q'_{ACK}-1}^{ACK}$ , where  $\underline{q}_i^{ACK}$ ,

$i = 0, \dots, Q'_{ACK} - 1$  are column vectors of length  $(Q_m \cdot N_L)$  and where  $Q'_{ACK} = Q_{ACK} / Q_m$  is obtained as follows:

Set  $i, k$  to 0

while  $i < Q_{ACK}$

$$\hat{\underline{q}}_k^{ACK} = [q_i^{ACK} \ \dots \ q_{i+Q_m-1}^{ACK}] \text{ -- temporary row vector}$$

$$\underline{q}_k^{ACK} = [\hat{\underline{q}}_k^{ACK} \ \dots \ \hat{\underline{q}}_k^{ACK}]^T \text{ -- replicating the row vector } \hat{\underline{q}}_k^{ACK} \text{ } N_L \text{ times and transposing into a column vector}$$

$$i = i + Q_m$$

$$k = k + 1$$

end while

where  $N_L$  is the number of layers onto which the UL-SCH transport block is mapped.

For rank indication (RI) (RI only, joint report of RI and i1, and joint report of RI and PTI)

- The corresponding bit widths for RI feedback for PDSCH transmissions are given by Tables 5.2.2.6.1-2, 5.2.2.6.2-3, 5.2.2.6.3-3, 5.2.3.3.1-3, 5.2.3.3.1-3A, 5.2.3.3.2-4, and 5.2.3.3.2-4A, which are determined assuming the maximum number of layers as follows:
  - If the UE is configured with transmission mode 9, and the *supportedMIMO-CapabilityDL-r10* field is included in the *UE-EUTRA-Capability*, the maximum number of layers is determined according to the minimum of the configured number of CSI-RS ports and the maximum of the reported UE downlink MIMO capabilities for the same band in the corresponding band combination.
  - If the UE is configured with transmission mode 9, and the *supportedMIMO-CapabilityDL-r10* field is not included in the *UE-EUTRA-Capability*, the maximum number of layers is determined according to the minimum of the configured number of CSI-RS ports and *ue-Category*.
  - If the UE is configured with transmission mode 3 or transmission mode 4, and the *maxLayersMIMO-r10* field is included in the *RRConnectionReconfiguration* for a DL cell, the maximum number of layers is determined according to *maxLayersMIMO-r10* for the DL cell.

- Otherwise the maximum number of layers is determined according to the minimum of the number of PBCH antenna ports and *ue-Category*.
- If RI feedback consists of 1-bit of information, i.e.,  $[o_0^{RI}]$ , it is first encoded according to Table 5.2.2.6-3. The  $[o_0^{RI}]$  to RI mapping is given by Table 5.2.2.6-5.
- If RI feedback consists of 2-bits of information, i.e.,  $[o_0^{RI} o_1^{RI}]$  with  $o_0^{RI}$  corresponding to MSB of 2-bit input and  $o_1^{RI}$  corresponding to LSB, it is first encoded according to Table 5.2.2.6-4 where  $o_2^{RI} = (o_0^{RI} + o_1^{RI}) \bmod 2$ . The  $[o_0^{RI} o_1^{RI}]$  to RI mapping is given by Table 5.2.2.6-6.

**Table 5.2.2.6-3: Encoding of 1-bit RI.**

$Q_m$	Encoded RI
2	$[o_0^{RI} y]$
4	$[o_0^{RI} y x x]$
6	$[o_0^{RI} y x x x x]$

**Table 5.2.2.6-4: Encoding of 2-bit RI.**

$Q_m$	Encoded RI
2	$[o_0^{RI} o_1^{RI} o_2^{RI} o_0^{RI} o_1^{RI} o_2^{RI}]$
4	$[o_0^{RI} o_1^{RI} x x o_2^{RI} o_0^{RI} x x o_1^{RI} o_2^{RI} x x]$
6	$[o_0^{RI} o_1^{RI} x x x x o_2^{RI} o_0^{RI} x x x x o_1^{RI} o_2^{RI} x x x x]$

**Table 5.2.2.6-5:  $o_0^{RI}$  to RI mapping.**

$o_0^{RI}$	RI
0	1
1	2

**Table 5.2.2.6-6:  $o_0^{RI}, o_1^{RI}$  to RI mapping.**

$o_0^{RI}, o_1^{RI}$	RI
0, 0	1
0, 1	2
1, 0	3
1, 1	4

**Table 5.2.2.6-7:  $o_0^{RI}, o_1^{RI}, o_2^{RI}$  to RI mapping.**

$o_0^{RI}, o_1^{RI}, o_2^{RI}$	RI
0, 0, 0	1
0, 0, 1	2
0, 1, 0	3
0, 1, 1	4
1, 0, 0	5
1, 0, 1	6
1, 1, 0	7
1, 1, 1	8

- If RI feedback for a given DL cell consists of 3-bits of information, i.e.,  $[o_0^{RI} o_1^{RI} o_2^{RI}]$  with  $o_0^{RI}$  corresponding to MSB of 3-bit input and  $o_2^{RI}$  corresponding to LSB. The  $[o_0^{RI} o_1^{RI} o_2^{RI}]$  to RI mapping is given by Table 5.2.2.6-7.
- If RI feedback consists of  $3 \leq O^{RI} \leq 11$  bits of information, i.e.,  $[o_0^{RI} o_1^{RI}, \dots, o_{O^{RI}-1}^{RI}]$ , then a coded bit sequence  $[\tilde{q}_0^{RI} \tilde{q}_1^{RI}, \dots, \tilde{q}_{31}^{RI}]$  is obtained by using the bit sequence  $[o_0^{RI} o_1^{RI}, \dots, o_{O^{RI}-1}^{RI}]$  as the input to the channel coding block described in section 5.2.2.6.4.
- If RI feedback consists of  $11 < O^{RI} \leq 15$  bits of information as a result of the aggregation of RI bits corresponding to multiple DL cells, i.e.,  $[o_0^{RI} o_1^{RI}, \dots, o_{O^{RI}-1}^{RI}]$ , then the coded bit sequence  $q_0^{RI}, q_1^{RI}, q_2^{RI}, \dots, q_{Q_{RI}-1}^{RI}$  is obtained by using the bit sequence  $[o_0^{RI} o_1^{RI}, \dots, o_{O^{RI}-1}^{RI}]$  as the input to the channel coding block described in section 5.2.2.6.5.

The “x” and “y” in Table 5.2.2.6-3 and 5.2.2.6-4 are placeholders for [2] to scramble the RI bits in a way that maximizes the Euclidean distance of the modulation symbols carrying rank information.

For the case where RI feedback for more than one DL cell is to be reported, the RI report for each DL cell is concatenated prior to coding in increasing order of cell index.

For the case where RI feedback consists of one or two bits of information the bit sequence  $q_0^{RI}, q_1^{RI}, q_2^{RI}, \dots, q_{Q_{RI}-1}^{RI}$  is obtained by concatenation of multiple encoded RI blocks where  $Q_{RI}$  is the total number of coded bits for all the encoded RI blocks. The last concatenation of the encoded RI block may be partial so that the total bit sequence length is equal to  $Q_{RI}$ .

For the case where RI feedback consists of  $3 \leq O^{RI} \leq 11$  bits of information, the bit sequence  $q_0^{RI}, q_1^{RI}, q_2^{RI}, \dots, q_{Q_{RI}-1}^{RI}$  is obtained by the circular repetition of the bit sequence  $\tilde{q}_0^{RI} \tilde{q}_1^{RI}, \dots, \tilde{q}_{31}^{RI}$  so that the total bit sequence length is equal to  $Q_{RI}$ .

When rank information is to be multiplexed with UL-SCH at a given PUSCH, the rank information is multiplexed in all layers of all transport blocks of that PUSCH. For a given transport block, the vector sequence output of the channel coding for rank information is denoted by  $\underline{q}_0^{RI}, \underline{q}_1^{RI}, \dots, \underline{q}_{Q'_{RI}-1}^{RI}$ , where  $\underline{q}_i^{RI}$ ,  $i = 0, \dots, Q'_{RI} - 1$  are column vectors of length  $(Q_m \cdot N_L)$  and where  $Q'_{RI} = Q_{RI} / Q_m$ . The vector sequence is obtained as follows:

Set  $i, j, k$  to 0

while  $i < Q_{RI}$

$$\hat{q}_k^{RI} = [q_i^{RI} \dots q_{i+Q_m-1}^{RI}] \text{ -- temporary row vector}$$

$$\underline{q}_k^{RI} = \overbrace{[\hat{q}_k^{RI} \dots \hat{q}_k^{RI}]^T}^{N_L} \text{ -- replicating the row vector } \hat{q}_k^{RI} \text{ } N_L \text{ times and transposing into a column vector}$$

$$i = i + Q_m$$

$$k = k + 1$$

end while

where  $N_L$  is the number of layers onto which the UL-SCH transport block is mapped.



For channel quality control information (CQI and/or PMI denoted as CQI/PMI)

When the UE transmits channel quality control information bits, it shall determine the number of modulation coded symbols per layer  $Q'$  for channel quality information as

$$Q' = \min \left( \left[ \frac{(O + L) \cdot M_{sc}^{PUSCH-initial(x)} \cdot N_{symbol}^{PUSCH-initial(x)} \cdot \beta_{offset}^{PUSCH}}{\sum_{r=0}^{C^{(x)}-1} K_r^{(x)}} \right], M_{sc}^{PUSCH} \cdot N_{symbol}^{PUSCH} - \frac{Q_{RI}^{(x)}}{Q_m^{(x)}} \right)$$

where  $O$  is the number of CQI/PMI bits,  $L$  is the number of CRC bits given by  $L = \begin{cases} 0 & O \leq 11 \\ 8 & \text{otherwise} \end{cases}$ ,

$Q_{CQI} = Q_m^{(x)} \cdot Q'$  and  $\beta_{offset}^{PUSCH} = \beta_{offset}^{CQI}$ , where  $\beta_{offset}^{CQI}$  shall be determined according to [3] depending on the number of transmission codewords for the corresponding PUSCH. If RI is not transmitted then  $Q_{RI}^{(x)} = 0$ .

The variable “ $x$ ” in  $K_r^{(x)}$  represents the transport block index corresponding to the highest  $I_{MCS}$  value indicated by the initial UL grant. In case the two transport blocks have the same  $I_{MCS}$  value in the corresponding initial UL grant, “ $x=1$ ”, which corresponds to the first transport block.  $M_{sc}^{PUSCH-initial(x)}$ ,  $C^{(x)}$ , and  $K_r^{(x)}$  are obtained from the initial PDCCH for the same transport block. If there is no initial PDCCH with DCI format 0 for the same transport block,  $M_{sc}^{PUSCH-initial(x)}$ ,  $C^{(x)}$ , and  $K_r^{(x)}$  shall be determined from:

- the most recent semi-persistent scheduling assignment PDCCH, when the initial PUSCH for the same transport block is semi-persistently scheduled, or,
- the random access response grant for the same transport block, when the PUSCH is initiated by the random access response grant.

$N_{symbol}^{PUSCH-initial(x)}$  is the number of SC-FDMA symbols per subframe for initial PUSCH transmission for the same transport block.

For UL-SCH data information  $G = N_L^{(x)} \cdot (N_{symbol}^{PUSCH} \cdot M_{sc}^{PUSCH} \cdot Q_m^{(x)} - Q_{CQI} - Q_{RI}^{(x)})$ , where  $N_L^{(x)}$  is the number of layers the corresponding UL-SCH transport block is mapped onto,  $M_{sc}^{PUSCH}$  is the scheduled bandwidth for PUSCH transmission in the current sub-frame for the transport block, and  $N_{symbol}^{PUSCH}$  is the number of SC-FDMA symbols in the current PUSCH transmission sub-frame given by  $N_{symbol}^{PUSCH} = (2 \cdot (N_{symbol}^{UL} - 1) - N_{SRS})$ , where  $N_{SRS}$  is equal to 1 if UE transmits PUSCH and SRS in the same subframe for the current subframe, or if the PUSCH resource allocation for the current subframe even partially overlaps with the cell-specific SRS subframe and bandwidth configuration defined in section 5.5.3 of [2], or if the current subframe is a UE-specific type-1 SRS subframe as defined in Section 8.2 of [3]. Otherwise  $N_{SRS}$  is equal to 0.

In case of CQI/PMI report for more than one DL cell,  $o_0, o_1, o_2, \dots, o_{O-1}$  is the result of concatenating the CQI/PMI report for each DL cell in increasing order of cell index.

- If the payload size is less than or equal to 11 bits, the channel coding of the channel quality information is performed according to section 5.2.2.6.4 with input sequence  $o_0, o_1, o_2, \dots, o_{O-1}$ .
- For payload sizes greater than 11 bits, the CRC attachment, channel coding and rate matching of the channel quality information is performed according to sections 5.1.1, 5.1.3.1 and 5.1.4.2, respectively. The input bit sequence to the CRC attachment operation is  $o_0, o_1, o_2, \dots, o_{O-1}$ . The output bit sequence of the CRC attachment operation is the input bit sequence to the channel coding operation. The output bit sequence of the channel coding operation is the input bit sequence to the rate matching operation.

The output sequence for the channel coding of channel quality information is denoted by  $q_0, q_1, q_2, q_3, \dots, q_{N_L \cdot Q_{CQI} - 1}$ , where  $N_L$  is the number of layers the corresponding UL-SCH transport block is mapped onto.

### 5.2.2.6.1 Channel quality information formats for wideband CQI reports

Table 5.2.2.6.1-1 and Table 5.2.2.6.1-1A show the fields and the corresponding bit widths for the channel quality information feedback for wideband reports for PDSCH transmissions associated with transmission mode 4, transmission mode 6, transmission mode 8 configured with PMI/RI reporting, and transmission mode 9 configured with PMI/RI reporting with 2/4/8 antenna ports.  $N$  in Table 5.2.2.6.1-1 is defined in section 7.2 of [3].

**Table 5.2.2.6.1-1: Fields for channel quality information feedback for wideband CQI reports (transmission mode 4, transmission mode 6, transmission mode 8 configured with PMI/RI reporting, and transmission mode 9 configured with PMI/RI reporting with 2/4 antenna ports).**

Field	Bit width			
	2 antenna ports		4 antenna ports	
	Rank = 1	Rank = 2	Rank = 1	Rank > 1
Wideband CQI codeword 0	4	4	4	4
Wideband CQI codeword 1	0	4	0	4
Precoding matrix indicator	$2N$	$N$	$4N$	$4N$

**Table 5.2.2.6.1-1A: Fields for channel quality information feedback for wideband CQI reports (transmission mode 9 configured with PMI/RI reporting with 8 antenna ports).**

Field	Bit width			
	Rank = 1	Rank = 2	Rank = 3	Rank = 4
Wideband CQI codeword 0	4	4	4	4
Wideband CQI codeword 1	0	4	4	4
Wideband first PMI $i_1$	4	4	2	2
Subband second PMI $i_2$	$4N$	$4N$	$4N$	$3N$
Field	Bit width			
	Rank = 5	Rank = 6	Rank = 7	Rank = 8
Wideband CQI codeword 0	4	4	4	4
Wideband CQI codeword 1	4	4	4	4
Wideband first PMI $i_1$	2	2	2	0
Subband second PMI $i_2$	0	0	0	0

Table 5.2.2.6.1-2 shows the fields and the corresponding bit width for the rank indication feedback for wideband CQI reports for PDSCH transmissions associated with transmission mode 4, transmission mode 8 configured with PMI/RI reporting, and transmission mode 9 configured with PMI/RI reporting with 2/4/8 antenna ports.

**Table 5.2.2.6.1-2: Fields for rank indication feedback for wideband CQI reports (transmission mode 4, transmission mode 8 configured with PMI/RI reporting, and transmission mode 9 configured with PMI/RI reporting with 2/4/8 antenna ports).**

Field	Bit width					
	2 antenna ports	4 antenna ports		8 antenna ports		
		Max 2 layers	Max 4 layers	Max 2 layers	Max 4 layers	Max 8 layers
Rank indication	1	1	2	1	2	3

The channel quality bits in Table 5.2.2.6.1-1 and Table 5.2.2.6.1-1A form the bit sequence  $o_0, o_1, o_2, \dots, o_{O-1}$  with  $o_0$  corresponding to the first bit of the first field in the table,  $o_1$  corresponding to the second bit of the first field in the table, and  $o_{O-1}$  corresponding to the last bit in the last field in the table. The field of PMI shall be in the increasing order of the subband index [3]. The first bit of each field corresponds to MSB and the last bit LSB. The RI bits sequence in Table 5.2.2.6.1-2 is encoded according to section 5.2.2.6.

### 5.2.2.6.2 Channel quality information formats for higher layer configured subband CQI reports

Table 5.2.2.6.2-1 shows the fields and the corresponding bit width for the channel quality information feedback for higher layer configured report for PDSCH transmissions associated with transmission mode 1, transmission mode 2, transmission mode 3, transmission mode 7, transmission mode 8 configured without PMI/RI reporting and transmission mode 9 configured without PMI/RI reporting or configured with 1 antenna port.  $N$  in Table 5.2.2.6.2-1 is defined in section 7.2 of [3].

**Table 5.2.2.6.2-1: Fields for channel quality information feedback for higher layer configured subband CQI reports (transmission mode 1, transmission mode 2, transmission mode 3, transmission mode 7, transmission mode 8 configured without PMI/RI reporting, and transmission mode 9 configured without PMI/RI reporting or configured with 1 antenna port).**

Field	Bit width
Wide-band CQI codeword	4
Subband differential CQI	$2N$

Table 5.2.2.6.2-2 and Table 5.2.2.6.2-2A show the fields and the corresponding bit widths for the channel quality information feedback for higher layer configured report for PDSCH transmissions associated with transmission mode 4, transmission mode 5, transmission mode 6, transmission mode 8 configured with PMI/RI reporting, and transmission mode 9 configured with PMI/RI reporting with 2/4/8 antenna ports.  $N$  in Table 5.2.2.6.2-2 is defined in section 7.2 of [3].

**Table 5.2.2.6.2-2: Fields for channel quality information feedback for higher layer configured subband CQI reports (transmission mode 4, transmission mode 5, transmission mode 6, transmission mode 8 configured with PMI/RI reporting, and transmission mode 9 configured with PMI/RI reporting with 2/4 antenna ports).**

Field	Bit width			
	2 antenna ports		4 antenna ports	
	Rank = 1	Rank = 2	Rank = 1	Rank > 1
Wide-band CQI codeword 0	4	4	4	4
Subband differential CQI codeword 0	$2N$	$2N$	$2N$	$2N$
Wide-band CQI codeword 1	0	4	0	4
Subband differential CQI codeword 1	0	$2N$	0	$2N$
Precoding matrix indicator	2	1	4	4

**Table 5.2.2.6.2-2A: Fields for channel quality information feedback for higher layer configured subband CQI reports (transmission mode 9 configured with PMI/RI reporting with 8 antenna ports).**

Field	Bitwidth			
	Rank = 1	Rank = 2	Rank = 3	Rank = 4

Wideband CQI codeword 0	4	4	4	4
Subband differential CQI codeword 0	$2N$	$2N$	$2N$	$2N$
Wideband CQI codeword 1	0	4	4	4
Subband differential CQI codeword 1	0	$2N$	$2N$	$2N$
Wideband first PMI i1	4	4	2	2
Subband second PMI i2	4	4	4	3
<b>Field</b>				
	<b>Bitwidth</b>			
	<b>Rank = 5</b>	<b>Rank = 6</b>	<b>Rank = 7</b>	<b>Rank = 8</b>
Wideband CQI codeword 0	4	4	4	4
Subband differential CQI codeword 0	$2N$	$2N$	$2N$	$2N$
Wideband CQI codeword 1	4	4	4	4
Subband differential CQI codeword 1	$2N$	$2N$	$2N$	$2N$
Wideband first PMI i1	2	2	2	0
Subband second PMI i2	0	0	0	0

Table 5.2.2.6.2-3 shows the fields and the corresponding bit width for the rank indication feedback for higher layer configured subband CQI reports for PDSCH transmissions associated with transmission mode 3, transmission mode 4, transmission mode 8 configured with PMI/RI reporting, and transmission mode 9 configured with PMI/RI reporting with 2/4/8 antenna ports.

**Table 5.2.2.6.2-3: Fields for rank indication feedback for higher layer configured subband CQI reports (transmission mode 3, transmission mode 4, transmission mode 8 configured with PMI/RI reporting, and transmission mode 9 configured with PMI/RI reporting with 2/4/8 antenna ports).**

Field	Bit width					
	2 antenna ports	4 antenna ports		8 antenna ports		
		Max 2 layers	Max 4 layers	Max 2 layers	Max 4 layers	Max 8 layers
Rank indication	1	1	2	1	2	3

The channel quality bits in Table 5.2.2.6.2-1, Table 5.2.2.6.2-2 and Table 5.2.2.6.2-2A form the bit sequence  $o_0, o_1, o_2, \dots, o_{O-1}$  with  $o_0$  corresponding to the first bit of the first field in each of the tables,  $o_1$  corresponding to the second bit of the first field in each of the tables, and  $o_{O-1}$  corresponding to the last bit in the last field in each of the tables. The field of the PMI and subband differential CQI shall be in the increasing order of the subband index [3]. The first bit of each field corresponds to MSB and the last bit LSB. The RI bits sequence in Table 5.2.2.6.2-3 is encoded according to section 5.2.2.6.

### 5.2.2.6.3 Channel quality information formats for UE selected subband CQI reports

Table 5.2.2.6.3-1 shows the fields and the corresponding bit widths for the channel quality information feedback for UE selected subband CQI for PDSCH transmissions associated with transmission mode 1, transmission mode 2, transmission mode 3, transmission mode 7, transmission mode 8 configured without PMI/RI reporting, and transmission mode 9 configured without PMI/RI reporting or configured with 1 antenna port.  $L$  in Table 5.2.2.6.3-1 is defined in section 7.2 of [3].

**Table 5.2.2.6.3-1: Fields for channel quality information feedback for UE selected subband CQI reports (transmission mode 1, transmission mode 2, transmission mode 3, transmission mode 7, transmission mode 8 configured without PMI/RI reporting, and transmission mode 9 configured without PMI/RI reporting or configured with 1 antenna port).**

Field	Bit width
Wide-band CQI codeword	4
Subband differential CQI	2
Position of the M selected subbands	$L$

Table 5.2.2.6.3-2 and Table 5.2.2.6.3-2A show the fields and the corresponding bit widths for the channel quality information feedback for UE selected subband CQI for PDSCH transmissions associated with transmission mode 4,

transmission mode 6, transmission mode 8 configured with PMI/RI reporting, and transmission mode 9 configured with PMI/RI reporting with 2/4/8 antenna ports.  $L$  in Table 5.2.2.6.3-2 is defined in section 7.2 of [3].

**Table 5.2.2.6.3-2: Fields for channel quality information feedback for UE selected subband CQI reports (transmission mode 4, transmission mode 6, transmission mode 8 configured with PMI/RI reporting, and transmission mode 9 configured with PMI/RI reporting with 2/4 antenna ports).**

Field	Bit width			
	2 antenna ports		4 antenna ports	
	Rank = 1	Rank = 2	Rank = 1	Rank > 1
Wide-band CQI codeword 0	4	4	4	4
Subband differential CQI codeword 0	2	2	2	2
Wide-band CQI codeword 1	0	4	0	4
Subband differential CQI codeword 1	0	2	0	2
Position of the M selected subbands	$L$	$L$	$L$	$L$
Precoding matrix indicator	4	2	8	8

**Table 5.2.2.6.3-2A: Fields for channel quality information feedback for UE selected subband CQI reports (transmission mode 9 configured with PMI/RI reporting with 8 antenna ports).**

Field	Bit width							
	Rank = 1	Rank = 2	Rank = 3	Rank = 4	Rank = 5	Rank = 6	Rank = 7	Rank = 8
Wide-band CQI codeword 0	4	4	4	4	4	4	4	4
Subband differential CQI codeword 0	2	2	2	2	2	2	2	2
Wide-band CQI codeword 1	0	4	4	4	4	4	4	4
Subband differential CQI codeword 1	0	2	2	2	2	2	2	2
Position of the M selected subbands	$L$	$L$	$L$	$L$	$L$	$L$	$L$	$L$
Wideband first PMI $i_1$	4	4	2	2	2	2	2	0
Wideband second PMI $i_2$	4	4	4	3	0	0	0	0
Subband second PMI $i_2$	4	4	4	3	0	0	0	0

Table 5.2.2.6.3-3 shows the fields and the corresponding bit widths for the rank indication feedback for UE selected subband CQI reports for PDSCH transmissions associated with transmission mode 3, transmission mode 4, transmission mode 8 configured with PMI/RI reporting, and transmission mode 9 configured with PMI/RI reporting with 2/4/8 antenna ports.

**Table 5.2.2.6.3-3: Fields for rank indication feedback for UE selected subband CQI reports (transmission mode 3, transmission mode 4, transmission mode 8 configured with PMI/RI reporting, and transmission mode 9 configured with PMI/RI reporting with 2/4/8 antenna ports).**

Field	Bit width					
	2 antenna ports	4 antenna ports		8 antenna ports		
		Max 2 layers	Max 4 layers	Max 2 layers	Max 4 layers	Max 8 layers
Rank indication	1	1	2	1	2	3

The channel quality bits in Table 5.2.2.6.3-1, Table 5.2.2.6.3-2 and Table 5.2.2.6.3-2A form the bit sequence  $o_0, o_1, o_2, \dots, o_{O-1}$  with  $o_0$  corresponding to the first bit of the first field in each of the tables,  $o_1$  corresponding to the second bit of the first field in each of the tables, and  $o_{O-1}$  corresponding to the last bit in the last field in each of the tables. The field of PMI shall start with the wideband PMI followed by the PMI for the M selected subbands. The first bit of each field corresponds to MSB and the last bit LSB. The RI bits sequence in Table 5.2.2.6.3-3 is encoded according to section 5.2.2.6.

#### 5.2.2.6.4 Channel coding for CQI/PMI information in PUSCH

The channel quality bits input to the channel coding block are denoted by  $o_0, o_1, o_2, o_3, \dots, o_{O-1}$  where  $O$  is the number of bits. The number of channel quality bits depends on the transmission format. When PUCCH-based reporting format is used, the number of CQI/PMI bits is defined in section 5.2.3.3.1 for wideband reports and in section 5.2.3.3.2 for UE selected subbands reports. When PUSCH-based reporting format is used, the number of CQI/PMI bits is defined in section 5.2.2.6.1 for wideband reports, in section 5.2.2.6.2 for higher layer configured subbands reports and in section 5.2.2.6.3 for UE selected subbands reports.

The channel quality information is first coded using a  $(32, O)$  block code. The code words of the  $(32, O)$  block code are a linear combination of the 11 basis sequences denoted  $M_{i,n}$  and defined in Table 5.2.2.6.4-1.

**Table 5.2.2.6.4-1: Basis sequences for  $(32, O)$  code.**

$i$	$M_{i,0}$	$M_{i,1}$	$M_{i,2}$	$M_{i,3}$	$M_{i,4}$	$M_{i,5}$	$M_{i,6}$	$M_{i,7}$	$M_{i,8}$	$M_{i,9}$	$M_{i,10}$
0	1	1	0	0	0	0	0	0	0	0	1
1	1	1	1	0	0	0	0	0	0	1	1
2	1	0	0	1	0	0	1	0	1	1	1
3	1	0	1	1	0	0	0	0	1	0	1
4	1	1	1	1	0	0	0	1	0	0	1
5	1	1	0	0	1	0	1	1	1	0	1
6	1	0	1	0	1	0	1	0	1	1	1
7	1	0	0	1	1	0	0	1	1	0	1
8	1	1	0	1	1	0	0	1	0	1	1
9	1	0	1	1	1	0	1	0	0	1	1
10	1	0	1	0	0	1	1	1	0	1	1
11	1	1	1	0	0	1	1	0	1	0	1
12	1	0	0	1	0	1	0	1	1	1	1
13	1	1	0	1	0	1	0	1	0	1	1
14	1	0	0	0	1	1	0	1	0	0	1
15	1	1	0	0	1	1	1	1	0	1	1
16	1	1	1	0	1	1	1	0	0	1	0
17	1	0	0	1	1	1	0	0	1	0	0
18	1	1	0	1	1	1	1	1	0	0	0
19	1	0	0	0	0	1	1	0	0	0	0
20	1	0	1	0	0	0	1	0	0	0	1
21	1	1	0	1	0	0	0	0	0	1	1
22	1	0	0	0	1	0	0	1	1	0	1
23	1	1	1	0	1	0	0	0	1	1	1
24	1	1	1	1	1	0	1	1	1	1	0
25	1	1	0	0	0	1	1	1	0	0	1
26	1	0	1	1	0	1	0	0	1	1	0
27	1	1	1	1	0	1	0	1	1	1	0
28	1	0	1	0	1	1	1	0	1	0	0
29	1	0	1	1	1	1	1	1	1	0	0
30	1	1	1	1	1	1	1	1	1	1	1
31	1	0	0	0	0	0	0	0	0	0	0

The encoded CQI/PMI block is denoted by  $b_0, b_1, b_2, b_3, \dots, b_{B-1}$  where  $B = 32$  and

$$b_i = \sum_{n=0}^{O-1} (o_n \cdot M_{i,n}) \bmod 2 \quad \text{where } i = 0, 1, 2, \dots, B-1.$$

The output bit sequence  $q_0, q_1, q_2, q_3, \dots, q_{N_L \cdot Q_{CQI} - 1}$  is obtained by circular repetition of the encoded CQI/PMI block as follows

$q_i = b_{(i \bmod B)}$  where  $i = 0, 1, 2, \dots, N_L \cdot Q_{CQI} - 1$ , where  $N_L$  is the number of layers the corresponding UL-SCH transport block is mapped onto .

### 5.2.2.6.5 Channel coding for more than 11 bits of HARQ-ACK information

The HARQ-ACK bits input to the channel coding block are denoted by  $o_0^{ACK}, o_1^{ACK}, \dots, o_{O^{ACK}-1}^{ACK}$  where  $11 < O^{ACK} \leq 20$  is the number of bits.

The sequences of bits  $o_0^{ACK}, o_1^{ACK}, o_2^{ACK}, \dots, o_{\lceil O^{ACK}/2 \rceil - 1}^{ACK}$  and  $o_{\lceil O^{ACK}/2 \rceil}^{ACK}, o_{\lceil O^{ACK}/2 \rceil + 1}^{ACK}, o_{\lceil O^{ACK}/2 \rceil + 2}^{ACK}, \dots, o_{O^{ACK}-1}^{ACK}$  are encoded as follows

$$\tilde{q}_i = \sum_{n=0}^{\lceil O^{ACK}/2 \rceil - 1} (o_n^{ACK} \cdot M_{i,n}) \bmod 2$$

and

$$\tilde{\tilde{q}}_i = \sum_{n=0}^{O^{ACK} - \lceil O^{ACK}/2 \rceil - 1} (o_{\lceil O^{ACK}/2 \rceil + n}^{ACK} \cdot M_{i,n}) \bmod 2$$

where  $i = 0, 1, 2, \dots, 31$  and the basis sequences  $M_{i,n}$  are defined in Table 5.2.2.6.4-1.

The output bit sequence  $q_0^{ACK}, q_1^{ACK}, q_2^{ACK}, \dots, q_{O^{ACK}-1}^{ACK}$  is obtained by the concatenation and circular repetition of the bit sequences  $\tilde{q}_0, \tilde{q}_1, \tilde{q}_2, \dots, \tilde{q}_{31}$  and  $\tilde{\tilde{q}}_0, \tilde{\tilde{q}}_1, \tilde{\tilde{q}}_2, \dots, \tilde{\tilde{q}}_{31}$  as follows:

Set  $i = 0$

while  $i < \lceil Q'/2 \rceil \cdot Q_m$

$$q_i^{ACK} = \tilde{q}_{i \bmod 32}$$

$i = i + 1$

end while

Set  $i = 0$

while  $i < (Q' - \lceil Q'/2 \rceil) \cdot Q_m$

$$q_{\lceil Q'/2 \rceil Q_m + i}^{ACK} = \tilde{\tilde{q}}_{i \bmod 32}$$

$i = i + 1$

end while

### 5.2.2.7 Data and control multiplexing

The control and data multiplexing is performed such that HARQ-ACK information is present on both slots and is mapped to resources around the demodulation reference signals. In addition, the multiplexing ensures that control and data information are mapped to different modulation symbols.

The inputs to the data and control multiplexing are the coded bits of the control information denoted by  $q_0, q_1, q_2, q_3, \dots, q_{N_L \cdot Q_{CQI}-1}$  and the coded bits of the UL-SCH denoted by  $f_0, f_1, f_2, f_3, \dots, f_{G-1}$ . The output of the data and control multiplexing operation is denoted by  $\underline{g}_0, \underline{g}_1, \underline{g}_2, \underline{g}_3, \dots, \underline{g}_{H'-1}$ , where  $H = (G + N_L \cdot Q_{CQI})$  and  $H' = H / (N_L \cdot Q_m)$ , and where  $\underline{g}_i$ ,  $i = 0, \dots, H' - 1$  are column vectors of length  $(Q_m \cdot N_L)$ .  $H$  is the total number of coded bits allocated for UL-SCH data and CQI/PMI information across the  $N_L$  transmission layers of the transport block.

In case where more than one UL-SCH transport block are transmitted in a subframe of an UL cell, the CQI/PMI information is multiplexed with data only on the UL-SCH transport block with highest  $I_{MCS}$  value on the initial grant. In case the two transport blocks have the same  $I_{MCS}$  value in the corresponding initial UL grant, the CQI/PMI information is multiplexed with data only on the first transport block. For that UL-SCH transport block or in the case of single transport block transmission, and assuming that  $N_L$  is the number of layers onto which the UL-SCH transport block is mapped, the control information and the data shall be multiplexed as follows:

Set  $i, j, k$  to 0

while  $j < N_L \cdot Q_{CQI}$  -- first place the control information

$$\underline{g}_k = [q_j \dots q_{j+N_L \cdot Q_m - 1}]^T$$

$$j = j + N_L \cdot Q_m$$

$$k = k + 1$$

end while

while  $i < G$  -- then place the data

$$\underline{f}_k = [f_i \dots f_{i+Q_m \cdot N_L - 1}]^T$$

$$i = i + Q_m \cdot N_L$$

$$k = k + 1$$

end while

### 5.2.2.8 Channel interleaver

The channel interleaver described in this section in conjunction with the resource element mapping for PUSCH in [2] implements a time-first mapping of modulation symbols onto the transmit waveform while ensuring that the HARQ-ACK and RI information are present on both slots in the subframe. HARQ-ACK information is mapped to resources around the uplink demodulation reference signals while RI information is mapped to resources around those used by HARQ-ACK.

The input to the channel interleaver are denoted by  $\underline{g}_0, \underline{g}_1, \underline{g}_2, \dots, \underline{g}_{H'-1}, \underline{q}_0^{RI}, \underline{q}_1^{RI}, \underline{q}_2^{RI}, \dots, \underline{q}_{Q_{RI}-1}^{RI}$  and

$\underline{q}_0^{ACK}, \underline{q}_1^{ACK}, \underline{q}_2^{ACK}, \dots, \underline{q}_{Q_{ACK}-1}^{ACK}$ . In case where more than one UL-SCH transport block are transmitted in a subframe of an UL cell, the HARQ-ACK and RI information are multiplexed with data on both UL-SCH transport blocks.

The number of modulation symbols per layer in the subframe is given by  $H'_{total} = H' + Q_{RI}'$ . The output bit sequence from the channel interleaver is derived as follows:

(1) Assign  $C_{mux} = N_{\text{sym}}^{\text{PUSCH}}$  to be the number of columns of the matrix. The columns of the matrix are numbered 0, 1, 2, ...,  $C_{mux} - 1$  from left to right.  $N_{\text{sym}}^{\text{PUSCH}}$  is determined according to section 5.2.2.6.

(2) The number of rows of the matrix is  $R_{mux} = (H'_{total} \cdot Q_m \cdot N_L) / C_{mux}$  and we define  $R'_{mux} = R_{mux} / (Q_m \cdot N_L)$ .

The rows of the rectangular matrix are numbered 0, 1, 2, ...,  $R_{mux} - 1$  from top to bottom.

(3) If rank information is transmitted in this subframe, the vector sequence  $\underline{q}_0^{RI}, \underline{q}_1^{RI}, \underline{q}_2^{RI}, \dots, \underline{q}_{Q_{RI}-1}^{RI}$  is written onto the columns indicated by Table 5.2.2.8-1, and by sets of  $(Q_m \cdot N_L)$  rows starting from the last row and moving upwards according to the following pseudo-code.

Set  $i, j$  to 0.



Set  $r$  to  $R'_{mux} - 1$

while  $i < Q'_{RI}$

$c_{RI} = \text{ColumnSet}(j)$

$$\underline{y}_{r \times C_{mux} + c_{RI}} = \underline{q}_i^{RI}$$

$i = i + 1$

$r = R'_{mux} - 1 - \lfloor i/4 \rfloor$

$j = (j + 3) \bmod 4$

end while

Where ColumnSet is given in Table 5.2.2.8-1 and indexed left to right from 0 to 3.

- (4) Write the input vector sequence, for  $k = 0, 1, \dots, H' - 1$ , into the  $(R_{mux} \times C_{mux})$  matrix by sets of  $(Q_m \cdot N_L)$  rows starting with the vector  $\underline{y}_0$  in column 0 and rows 0 to  $(Q_m \cdot N_L - 1)$  and skipping the matrix entries that are already occupied:

$$\begin{bmatrix} \underline{y}_0 & \underline{y}_1 & \underline{y}_2 & \cdots & \underline{y}_{C_{mux}-1} \\ \underline{y}_{C_{mux}} & \underline{y}_{C_{mux}+1} & \underline{y}_{C_{mux}+2} & \cdots & \underline{y}_{2C_{mux}-1} \\ \vdots & \vdots & \vdots & \ddots & \vdots \\ \underline{y}_{(R'_{mux}-1) \times C_{mux}} & \underline{y}_{(R'_{mux}-1) \times C_{mux}+1} & \underline{y}_{(R'_{mux}-1) \times C_{mux}+2} & \cdots & \underline{y}_{(R'_{mux}-1) \times C_{mux}-1} \end{bmatrix}$$

The pseudocode is as follows:

Set  $i, k$  to 0.

while  $k < H'$ ,

if  $\underline{y}_i$  is not assigned to RI symbols

$$\underline{y}_i = \underline{g}_k$$

$k = k + 1$

end if

$i = i + 1$

end while

- (5) If HARQ-ACK information is transmitted in this subframe, the vector sequence  $\underline{q}_0^{ACK}, \underline{q}_1^{ACK}, \underline{q}_2^{ACK}, \dots, \underline{q}_{Q'_{ACK}-1}^{ACK}$  is written onto the columns indicated by Table 5.2.2.8-2, and by sets of  $(Q_m \cdot N_L)$  rows starting from the last row and moving upwards according to the following pseudo-code. Note that this operation overwrites some of the channel interleaver entries obtained in step (4).

Set  $i, j$  to 0.

Set  $r$  to  $R'_{mux} - 1$

while  $i < Q'_{ACK}$

$c_{ACK} = \text{ColumnSet}(j)$

$$\underline{y}_{r \times C_{max} + c_{ACK}} = \underline{q}_i^{ACK}$$

$$i = i + 1$$

$$r = R'_{max} - 1 - \lfloor i/4 \rfloor$$

$$j = (j + 3) \bmod 4$$

end while

Where ColumnSet is given in Table 5.2.2.8-2 and indexed left to right from 0 to 3.

- (6) The output of the block interleaver is the bit sequence read out column by column from the  $(R_{mux} \times C_{mux})$  matrix. The bits after channel interleaving are denoted by  $h_0, h_1, h_2, \dots, h_{H+N_L \cdot Q_{RI} - 1}$ , where  $N_L$  is the number of layers the corresponding UL-SCH transport block is mapped onto.

**Table 5.2.2.8-1: Column set for Insertion of rank information.**

CP configuration	Column Set
Normal	{1, 4, 7, 10}
Extended	{0, 3, 5, 8}

**Table 5.2.2.8-2: Column set for Insertion of HARQ-ACK information.**

CP configuration	Column Set
Normal	{2, 3, 8, 9}
Extended	{1, 2, 6, 7}

### 5.2.3 Uplink control information on PUCCH

Data arrives to the coding unit in the form of indicators for measurement indication, scheduling request and HARQ acknowledgement.

Three forms of channel coding are used, one for the channel quality information CQI/PMI, another for HARQ-ACK (acknowledgement) and scheduling request and another for combination of CQI/PMI and HARQ-ACK.

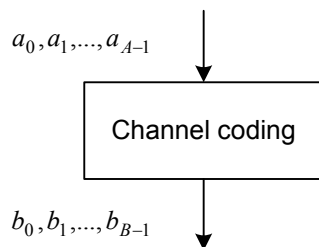

**Figure 5.2.3-1: Processing for UCI.**

#### 5.2.3.1 Channel coding for UCI HARQ-ACK

The HARQ-ACK bits are received from higher layers for each subframe of each cell. Each positive acknowledgement (ACK) is encoded as a binary ‘1’ and each negative acknowledgement (NACK) is encoded as a binary ‘0’. For the case where PUCCH format 3 [2] is configured by higher layers and is used for transmission of the HARQ-ACK feedback information, the HARQ-ACK feedback consists of the concatenation of HARQ-ACK bits for each of the serving cells.

For cells configured with transmission modes 1, 2, 5, 6 or 7 [3], i.e., single codeword transmission modes, 1 bit of HARQ-ACK information,  $a_k$ , is used for that cell. For cells configured with other transmission modes, 2 bits of HARQ-ACK information are used for those cells, i.e.,  $a_k, a_{k+1}$  with  $a_k$  corresponding to HARQ-ACK bit for codeword 0 and  $a_{k+1}$  corresponding to that for codeword 1.

Define  $N_{A/N}^{\text{PUCCH format 3}}$  as the number of HARQ-ACK bits including the possible concurrent transmission of scheduling request when PUCCH format 3 is used for transmission of HARQ-ACK feedback (section 10.1 in [3]).

For FDD, the sequence of bits  $a_0, a_1, a_2, \dots, a_{N_{A/N}^{\text{PUCCH format 3}}-1}$  is the result of the concatenation of HARQ-ACK bits for different cells according to the following pseudo-code:

Set  $c = 0$  – cell index: lower indices correspond to lower RRC indices of corresponding cell

Set  $j = 0$  – HARQ-ACK bit index

Set  $N_{cells}^{DL}$  to the number of cells configured by higher layers for the UE

while  $c < N_{cells}^{DL}$

if transmission mode configured in cell  $c \in \{1,2,5,6,7\}$  -- 1 bit HARQ-ACK feedback for this cell

$a_j =$  HARQ-ACK bit of this cell

$j = j + 1$

else

$a_j =$  HARQ-ACK bit corresponding to the first codeword of this cell

$j = j + 1$

$a_j =$  HARQ-ACK bit corresponding to the second codeword of this cell

$j = j + 1$

end if

$c = c + 1$

end while

For TDD, the sequence of bits  $a_0, a_1, a_2, \dots, a_{N_{A/N}^{\text{PUCCH format 3}}-1}$  is obtained from the HARQ-ACK bits for different cells and different subframes.

Define  $N_{cells}^{DL}$  as the number of cells configured by higher layers for the UE and  $B_c^{DL}$  as the number of downlink subframes for which the UE needs to feedback HARQ-ACK bits in cell  $c$  as defined in Section 7.3 of [3].

The number of HARQ-ACK bits for the UE to convey is computed as follows:

Set  $k = 0$  – counter of HARQ-ACK bits

Set  $c = 0$  – cell index: lower indices correspond to lower RRC indices of corresponding cell

while  $c < N_{cells}^{DL}$

set  $l = 0$ ;

while  $l < B_c^{DL}$

if transmission mode configured in cell  $c \in \{1,2,5,6,7\}$  -- 1 bit HARQ-ACK feedback for this cell

$k = k + 1$

else

$k = k + 2$

end if

$l = l + 1$

end while

$c = c + 1$

end while

If  $k \leq 20$ , the multiplexing of HARQ-ACK bits is performed according to the following pseudo-code:

Set  $c = 0$  – cell index: lower indices correspond to lower RRC indices of corresponding cell

Set  $j = 0$  – HARQ-ACK bit index

while  $c < N_{cells}^{DL}$

set  $l = 0$ ;

while  $l < B_c^{DL}$

if transmission mode configured in cell  $c \in \{1,2,5,6,7\}$  -- 1 bit HARQ-ACK feedback for this cell

$\tilde{o}_j^{ACK} = o_{c,l}^{ACK}$  HARQ-ACK bit of this cell as defined in Section 7.3 of [3]

$j = j + 1$

else

$[\tilde{o}_j^{ACK}, \tilde{o}_{j+1}^{ACK}] = [o_{c,2l}^{ACK}, o_{c,2l+1}^{ACK}]$  HARQ-ACK bit of this cell as defined in Section 7.3 of [3]

$j = j + 2$

end if

$l = l + 1$

end while

$c = c + 1$

end while

If  $k > 20$ , spatial bundling is applied to all subframes in all cells and the multiplexing of HARQ-ACK bits is performed according to the following pseudo-code

Set  $c = 0$  – cell index: lower indices correspond to lower RRC indices of corresponding cell

Set  $j = 0$  – HARQ-ACK bit index

while  $c < N_{cells}^{DL}$

set  $l = 0$ ;

while  $l < B_c^{DL}$

if transmission mode configured in cell  $c \in \{1,2,5,6,7\}$  – 1 bit HARQ-ACK feedback for this cell

$\tilde{o}_j^{ACK} = o_{c,l}^{ACK}$  HARQ-ACK bit of this cell as defined in Section 7.3 of [3]

$j = j + 1$

else

$\tilde{o}_j^{ACK} = o_{c,l}^{ACK}$  binary AND operation of the HARQ-ACK bits corresponding to the first and second codewords of this cell as defined in Section 7.3 of [3]

$j = j + 1$

end if

$l = l + 1$

end while

$c = c + 1$

end while

In case the transmission of HARQ-ACK feedback using PUCCH format 3 [2] coincides with a sub-frame configured to the UE by higher layers for transmission of scheduling request, the scheduling request bit (1 = positive SR; 0 = negative SR) is appended at the end of the sequence of concatenated HARQ-ACK bits.

For  $N_{A/N}^{\text{PUCCH format 3}} \leq 11$ , the bit sequence  $a_0, a_1, a_2, \dots, a_{N_{A/N}^{\text{PUCCH format 3}}-1}$  is obtained by setting  $a_i = \tilde{o}_i^{ACK}$ .

For  $11 < N_{A/N}^{\text{PUCCH format 3}} \leq 21$ , the bit sequence  $a_0, a_1, a_2, \dots, a_{N_{A/N}^{\text{PUCCH format 3}}-1}$  is obtained by setting  $a_{i/2} = \tilde{o}_i^{ACK}$  if  $i$  is even and  $a_{\lceil N_{A/N}^{\text{PUCCH format 3}}/2 \rceil + (i-1)/2} = \tilde{o}_i^{ACK}$  if  $i$  is odd.

For  $N_{A/N}^{\text{PUCCH format 3}} \leq 11$ , the sequence of bits  $a_0, a_1, a_2, \dots, a_{N_{A/N}^{\text{PUCCH format 3}}-1}$  is encoded as follows

$$\tilde{b}_i = \sum_{n=0}^{N_{A/N}^{\text{PUCCH format 3}}-1} (a_n \cdot M_{i,n}) \bmod 2$$

where  $i = 0, 1, 2, \dots, 31$  and the basis sequences  $M_{i,n}$  are defined in Table 5.2.2.6.4-1.

The output bit sequence  $b_0, b_1, b_2, \dots, b_{B-1}$  is obtained by circular repetition of the sequence  $\tilde{b}_0, \tilde{b}_1, \tilde{b}_2, \dots, \tilde{b}_{31}$

$$b_i = \tilde{b}_{(i \bmod 32)}$$

where  $i = 0, 1, 2, \dots, B-1$  and where  $B = 4 \cdot N_{sc}^{\text{RB}}$ .

For  $11 < N_{A/N}^{\text{PUCCH format 3}} \leq 21$ , the sequences of bits  $a_0, a_1, a_2, \dots, a_{\lceil N_{A/N}^{\text{PUCCH format 3}}/2 \rceil-1}$  and

$a_{\lceil N_{A/N}^{\text{PUCCH format 3}}/2 \rceil}, a_{\lceil N_{A/N}^{\text{PUCCH format 3}}/2 \rceil+1}, a_{\lceil N_{A/N}^{\text{PUCCH format 3}}/2 \rceil+2}, \dots, a_{N_{A/N}^{\text{PUCCH format 3}}-1}$  are encoded as follows

$$\tilde{b}_i = \sum_{n=0}^{\lceil N_{A/N}^{\text{PUCCH format 3}}/2 \rceil-1} (a_n \cdot M_{i,n}) \bmod 2$$

and

$$\tilde{b}_i = \sum_{n=0}^{N_{A/N}^{\text{PUCCH format 3}} - \lceil N_{A/N}^{\text{PUCCH format 3}}/2 \rceil - 1} \left( a_{\lceil N_{A/N}^{\text{PUCCH format 3}}/2 \rceil + n} \cdot M_{i,n} \right) \bmod 2$$

where  $i = 0, 1, 2, \dots, 23$  and the basis sequences  $M_{i,n}$  are defined in Table 5.2.2.6.4-1.

The output bit sequence  $b_0, b_1, b_2, \dots, b_{B-1}$  where  $B = 4 \cdot N_{sc}^{RB}$  is obtained by the alternate concatenation of the bit sequences  $\tilde{b}_0, \tilde{b}_1, \tilde{b}_2, \dots, \tilde{b}_{23}$  and  $\tilde{\tilde{b}}_0, \tilde{\tilde{b}}_1, \tilde{\tilde{b}}_2, \dots, \tilde{\tilde{b}}_{23}$  as follows

Set  $i, j = 0$

while  $i < 4 \cdot N_{sc}^{RB}$

$$b_i = \tilde{b}_j, b_{i+1} = \tilde{\tilde{b}}_{j+1}$$

$$b_{i+2} = \tilde{\tilde{b}}_j, b_{i+3} = \tilde{b}_{j+1}$$

$$i = i + 4$$

$$j = j + 2$$

end while

When PUCCH format 3 is not used for transmission of HARQ-ACK feedback, the HARQ-ACK bits are processed for transmission according to section 10.1 in [3].

### 5.2.3.2 Channel coding for UCI scheduling request

The scheduling request indication is received from higher layers and is processed according to [2].

### 5.2.3.3 Channel coding for UCI channel quality information

The channel quality bits input to the channel coding block are denoted by  $a_0, a_1, a_2, a_3, \dots, a_{A-1}$  where  $A$  is the number of bits. The number of channel quality bits depends on the transmission format as indicated in section 5.2.3.3.1 for wideband reports and in section 5.2.3.3.2 for UE-selected subbands reports.

The channel quality information is coded using a  $(20, A)$  code. The code words of the  $(20, A)$  code are a linear combination of the 13 basis sequences denoted  $M_{i,n}$  and defined in Table 5.2.3.3-1.

Table 5.2.3.3-1: Basis sequences for (20, A) code.

i	M <sub>i,0</sub>	M <sub>i,1</sub>	M <sub>i,2</sub>	M <sub>i,3</sub>	M <sub>i,4</sub>	M <sub>i,5</sub>	M <sub>i,6</sub>	M <sub>i,7</sub>	M <sub>i,8</sub>	M <sub>i,9</sub>	M <sub>i,10</sub>	M <sub>i,11</sub>	M <sub>i,12</sub>
0	1	1	0	0	0	0	0	0	0	0	1	1	0
1	1	1	1	0	0	0	0	0	0	1	1	1	0
2	1	0	0	1	0	0	1	0	1	1	1	1	1
3	1	0	1	1	0	0	0	0	1	0	1	1	1
4	1	1	1	1	0	0	0	1	0	0	1	1	1
5	1	1	0	0	1	0	1	1	1	0	1	1	1
6	1	0	1	0	1	0	1	0	1	1	1	1	1
7	1	0	0	1	1	0	0	1	1	0	1	1	1
8	1	1	0	1	1	0	0	1	0	1	1	1	1
9	1	0	1	1	1	0	1	0	0	1	1	1	1
10	1	0	1	0	0	1	1	1	0	1	1	1	1
11	1	1	1	0	0	1	1	0	1	0	1	1	1
12	1	0	0	1	0	1	0	1	1	1	1	1	1
13	1	1	0	1	0	1	0	1	0	1	1	1	1
14	1	0	0	0	1	1	0	1	0	0	1	0	1
15	1	1	0	0	1	1	1	1	0	1	1	0	1
16	1	1	1	0	1	1	1	0	0	1	0	1	1
17	1	0	0	1	1	1	0	0	1	0	0	1	1
18	1	1	0	1	1	1	1	1	0	0	0	0	0
19	1	0	0	0	0	1	1	0	0	0	0	0	0

After encoding the bits are denoted by  $b_0, b_1, b_2, b_3, \dots, b_{B-1}$  where  $B = 20$  and with

$$b_i = \sum_{n=0}^{A-1} (a_n \cdot M_{i,n}) \bmod 2 \quad \text{where } i = 0, 1, 2, \dots, B-1.$$

### 5.2.3.3.1 Channel quality information formats for wideband reports

Table 5.2.3.3.1-1 shows the fields and the corresponding bit widths for the channel quality information feedback for wideband reports for PDSCH transmissions associated with a transmission mode 1, transmission mode 2, transmission mode 3, transmission mode 7, transmission mode 8 configured without PMI/RI reporting, and transmission mode 9 configured without PMI/RI reporting or configured with 1 antenna port.

**Table 5.2.3.3.1-1: UCI fields for channel quality information feedback for wideband CQI reports (transmission mode 1, transmission mode 2, transmission mode 3, transmission mode 7, transmission mode 8 configured without PMI/RI reporting, and transmission mode 9 configured without PMI/RI reporting or configured with 1 antenna port).**

Field	Bit width
Wide-band CQI	4

Table 5.2.3.3.1-2 shows the fields and the corresponding bit widths for the channel quality and precoding matrix information feedback for wideband reports for PDSCH transmissions associated with transmission mode 4, transmission mode 5, transmission mode 6 and transmission mode 8 configured with PMI/RI reporting.

**Table 5.2.3.3.1-2: UCI fields for channel quality information feedback for wideband CQI reports (transmission mode 4, transmission mode 5, transmission mode 6 and transmission mode 8 configured with PMI/RI reporting).**

Field	Bit width			
	2 antenna ports		4 antenna ports	
	Rank = 1	Rank = 2	Rank = 1	Rank > 1
Wide-band CQI	4	4	4	4
Spatial differential CQI	0	3	0	3
Precoding matrix indicator	2	1	4	4

Table 5.2.3.3.1-2A and Table 5.2.3.3.1-2B show the fields and the corresponding bit widths for the channel quality and precoding matrix information feedback for wideband reports for PDSCH transmissions associated with transmission mode 9 configured with PMI/RI reporting.

**Table 5.2.3.3.1-2A: UCI fields for transmission of wideband CQI and precoding information (i2) for transmission mode 9 configured with PMI/RI reporting**

Field	Bit width							
	2 antenna ports		4 antenna ports		8 antenna ports			
	Rank = 1	Rank = 2	Rank = 1	Rank > 1	Rank = 1	Rank = 2,3	Rank = 4	Rank > 4
Wide-band CQI	4	4	4	4	4	4	4	4
Spatial differential CQI	0	3	0	3	0	3	3	3
Wide-band PMI (2 or 4 antenna ports) or i2 (8 antenna ports)	2	1	4	4	4	4	3	0

**Table 5.2.3.3.1-2B: UCI fields for transmission of wideband CQI and precoding information (i1, i2) for transmission mode 9 configured with PMI/RI reporting with 8 antenna ports**

Field	Bit width							
	8 antenna ports							
	Rank = 1	Rank = 2	Rank = 3	Rank = 4	Rank = 5	Rank = 6	Rank = 7	Rank = 8
Wide-band CQI	4	4	4	4	4	4	4	4
Spatial differential CQI	0	3	3	3	3	3	3	3
i1	3	3	1	1	2	2	2	0
Wide-band i2	1	1	3	3	0	0	0	0

Table 5.2.3.3.1-3 shows the fields and the corresponding bit widths for the rank indication feedback for wideband reports for PDSCH transmissions associated with transmission mode 3, transmission mode 4, transmission mode 8 configured with PMI/RI reporting, and transmission mode 9 configured with PMI/RI reporting with 2/4/8 antenna ports.

**Table 5.2.3.3.1-3: UCI fields for rank indication feedback for wideband reports (transmission mode 3, transmission mode 4, transmission mode 8 configured with PMI/RI reporting, and transmission mode 9 configured with PMI/RI reporting with 2/4/8 antenna ports).**

Field	Bit width					
	2 antenna ports	4 antenna ports		8 antenna ports		
		Max 2 layers	Max 4 layers	Max 2 layers	Max 4 layers	Max 8 layers
Rank indication	1	1	2	1	2	3

Table 5.2.3.3.1-3A shows the fields and the corresponding bit widths for the joint transmission of rank indication and i1 for wideband reports for PDSCH transmissions associated with transmission mode 9.



**Table 5.2.3.3.1-3A: UCI fields for joint report of RI and i1 (transmission mode 9 configured with PMI/RI reporting with 2/4/8 antenna ports)**

Field	Bit width					
	2 antenna ports	4 antenna ports		8 antenna ports		
		Max 2 layers	Max 4 layers	Max 2 layers	Max 4 layers	Max 8 layers
Rank indication	1	1	2	4	5	5
i1	-	-	-			

The channel quality bits in Table 5.2.3.3.1-1 through Table 5.2.3.3.1-3A form the bit sequence  $a_0, a_1, a_2, a_3, \dots, a_{A-1}$  with  $a_0$  corresponding to the first bit of the first field in each of the tables,  $a_1$  corresponding to the second bit of the first field in each of the tables, and  $a_{A-1}$  corresponding to the last bit in the last field in each of the tables. The first bit of each field corresponds to MSB and the last bit LSB. The RI feedback for one bit is mapped according to Table 5.2.2.6-5 with  $o_0^{RI}$  replaced by  $a_0$ . The RI feedback for two bits is mapped according to Table 5.2.2.6-6 with  $o_0^{RI}, o_1^{RI}$  replaced by  $a_0, a_1$ . The RI feedback for three bits is mapped according to Table 5.2.2.6-7 with  $o_0^{RI}, o_1^{RI}, o_2^{RI}$  replaced by  $a_0, a_1, a_2$ . The mapping for the jointly coded RI and i1 is provided in Table 7.2.2-1E of [3].

When multiplexed with UL-SCH, the channel coding and multiplexing for the transmission configurations in Table 5.2.3.3.1-3 and Table 5.2.3.3.1-3A is performed assuming RI transmission in section 5.2.2.6. All other transmission configurations in this section are coded and multiplexed assuming CQI/PMI transmission in section 5.2.2.6.

### 5.2.3.3.2 Channel quality information formats for UE-selected sub-band reports

Table 5.2.3.3.2-1 shows the fields and the corresponding bit widths for the sub-band channel quality information feedback for UE-selected sub-band reports for PDSCH transmissions associated with transmission mode 1, transmission mode 2, transmission mode 3, transmission mode 7, transmission mode 8 configured without PMI/RI reporting, and transmission mode 9 configured without PMI/RI reporting or configured with 1 antenna port.

**Table 5.2.3.3.2-1: UCI fields for channel quality information feedback for UE-selected sub-band CQI reports (transmission mode 1, transmission mode 2, transmission mode 3, transmission mode 7, transmission mode 8 configured without PMI/RI reporting, and transmission mode 9 configured without PMI/RI reporting or configured with 1 antenna port).**

Field	Bit width
Sub-band CQI	4
Sub-band label	1 or 2

Table 5.2.3.3.2-2 shows the fields and the corresponding bit widths for the sub-band channel quality information feedback for UE-selected sub-band reports for PDSCH transmissions associated with transmission mode 4, transmission mode 5, transmission mode 6 and transmission mode 8 configured with PMI/RI reporting.

**Table 5.2.3.3.2-2: UCI fields for channel quality information feedback for UE-selected sub-band reports (transmission mode 4, transmission mode 5, transmission mode 6 and transmission mode 8 configured with PMI/RI reporting).**

Field	Bit width			
	2 antenna ports		4 antenna ports	
	Rank = 1	Rank = 2	Rank = 1	Rank > 1
Sub-band CQI	4	4	4	4
Spatial differential CQI	0	3	0	3
Sub-band label	1 or 2	1 or 2	1 or 2	1 or 2

Table 5.2.3.3.2-2A and Table 5.2.3.3.2-2B show the fields and the corresponding bit widths for the sub-band channel quality information feedback for UE-selected sub-band reports for PDSCH transmissions associated with transmission mode 9 configured with PMI/RI reporting with 2/4/8 antenna ports.

**Table 5.2.3.3.2-2A: UCI fields for channel quality information feedback for UE-selected sub-band reports (transmission mode 9 configured with PMI/RI reporting with 2/4 antenna ports)**

Field	Bit width			
	2 antenna ports		4 antenna ports	
	Rank = 1	Rank = 2	Rank = 1	Rank > 1
Wide-band CQI	0	0	0	0
Sub-band CQI	4	4	4	4
Spatial differential CQI	0	3	0	3
Wide-band i2	0	0	0	0
Sub-band i2	0	0	0	0
Sub-band label	1 or 2	1 or 2	1 or 2	1 or 2

**Table 5.2.3.3.2-2B: UCI fields for channel quality information feedback for UE-selected sub-band reports (transmission mode 9 configured with PMI/RI reporting with 8 antenna ports)**

Field	Bit width									
	8 antenna ports									
	Rank = 1		Rank = 2, 3		Rank = 4		Rank = 5, 6, 7		Rank = 8	
	PTI=0	PTI=1	PTI=0	PTI=1	PTI=0	PTI=1	PTI=0	PTI=1	PTI=0	PTI=1
Wide-band CQI	4	0	4	0	4	0	4	0	4	0
Sub-band CQI	0	4	0	4	0	4	0	4	0	4
Spatial differential CQI	0	0	3	3	3	3	3	3	3	3
Wide-band i2	4	0	4	0	3	0	0	0	0	0
Sub-band i2	0	4	0	2	0	2	0	0	0	0
Sub-band label	0	1 or 2	0	1 or 2	0	1 or 2	0	1 or 2	0	1 or 2

Table 5.2.3.3.2-3 shows the fields and the corresponding bit widths for the wide-band channel quality and precoding matrix information feedback for UE-selected sub-band reports for PDSCH transmissions associated with transmission mode 4, transmission mode 5, transmission mode 6 and transmission mode 8 configured with PMI/RI reporting.

**Table 5.2.3.3.2-3: UCI fields for channel quality information feedback for UE-selected sub-band CQI reports (transmission mode 4, transmission mode 5, transmission mode 6 and transmission mode 8 configured with PMI/RI reporting).**

Field	Bit width			
	2 antenna ports		4 antenna ports	
	Rank = 1	Rank = 2	Rank = 1	Rank > 1
Wide-band CQI	4	4	4	4
Spatial differential CQI	0	3	0	3
Precoding matrix indicator	2	1	4	4

Table 5.2.3.3.2-3A and Table 5.2.3.3.2-3B show the fields and the corresponding bit widths for the wide-band channel quality and precoding matrix information feedback for UE-selected sub-band reports for PDSCH transmissions associated with transmission mode 9 configured with PMI/RI reporting with 2/4/8 antenna ports.

**Table 5.2.3.3.2-3A: UCI fields for wide-band channel quality and precoding matrix information feedback for UE-selected sub-band reports (transmission mode 9 configured with PMI/RI reporting with 2/4 antenna ports)**

Field	Bit width			
	2 antenna ports		4 antenna ports	
	Rank = 1	Rank = 2	Rank = 1	Rank > 1
Wide-band CQI	4	4	4	4
Spatial differential CQI	0	3	0	3
i1	0	0	0	0
Wide-band i2	2	1	4	4

**Table 5.2.3.3.2-3B: UCI fields for wide-band channel quality and precoding matrix information feedback for UE-selected sub-band reports (transmission mode 9 configured with PMI/RI reporting with 8 antenna ports)**

Field	Bit width					
	8 antenna ports					
	Rank = 1		Rank = 2		Rank = 3	
	PTI=0	PTI=1	PTI=0	PTI=1	PTI=0	PTI=1
Wide-band CQI	0	4	0	4	0	4
Spatial differential CQI	0	0	0	3	0	3
i1	4	0	4	0	2	0
Wide-band i2	0	4	0	4	0	4

Field	Bit width					
	8 antenna ports					
	Rank = 4		Rank = 5, 6, 7		Rank = 8	
	PTI=0	PTI=1	PTI=0	PTI=1	PTI=0	PTI=1
Wide-band CQI	0	4	0	4	0	4
Spatial differential CQI	0	3	0	3	0	3
i1	2	0	2	0	0	0
Wide-band i2	0	3	0	0	0	0

Table 5.2.3.3.2-4 shows the fields and the corresponding bit width for the rank indication feedback for UE-selected sub-band reports for PDSCH transmissions associated with transmission mode 3, transmission mode 4 and transmission mode 8 configured with PMI/RI reporting.

**Table 5.2.3.3.2-4: UCI fields for rank indication feedback for UE-selected sub-band reports (transmission mode 3, transmission mode 4 and transmission mode 8 configured with PMI/RI reporting).**

Field	Bit width		
	2 antenna ports	4 antenna ports	
		Max 2 layers	Max 4 layers
Rank indication	1	1	2

Table 5.2.3.3.2-4A shows the fields and the corresponding bit width for the rank indication and precoder type indication (PTI) feedback for UE-selected sub-band reports for PDSCH transmissions associated with transmission mode 9 configured with PMI/RI reporting with 2/4/8 antenna ports.

**Table 5.2.3.3.2-4A: UCI fields for joint report of RI and PTI (transmission mode 9 configured with PMI/RI reporting with 2/4/8 antenna ports)**

Field	Bit width					
	2 antenna ports	4 antenna ports		8 antenna ports		
		Max 2 layers	Max 4 layers	Max 2 layers	Max 4 layers	Max 8 layers
Rank indication	1	1	2	1	2	3
Precoder type indication	-	-	-	1	1	1

The channel quality bits in Table 5.2.3.3.2-1 through Table 5.2.3.3.2-4A form the bit sequence  $a_0, a_1, a_2, a_3, \dots, a_{A-1}$  with  $a_0$  corresponding to the first bit of the first field in each of the tables,  $a_1$  corresponding to the second bit of the first field in each of the tables, and  $a_{A-1}$  corresponding to the last bit in the last field in each of the tables. The first bit of each field corresponds to MSB and the last bit LSB. The RI feedback for one bit is mapped according to Table 5.2.2.6-5 with  $o_0^{RI}$  replaced by  $a_0$ . The RI feedback for two bits is mapped according to Table 5.2.2.6-6 with  $o_0^{RI}, o_1^{RI}$  replaced by  $a_0, a_1$ . The RI feedback for three bits is mapped according to Table 5.2.2.6-7 with  $o_0^{RI}, o_1^{RI}, o_2^{RI}$  replaced by  $a_0, a_1, a_2$ .

When multiplexed with UL-SCH, the channel coding and multiplexing for the transmission configurations in Table 5.2.3.3.2-4 and Table 5.2.3.3.2-4A is performed assuming RI transmission in section 5.2.2.6. All other transmission configurations in this section are coded and multiplexed assuming CQI/PMI transmission in section 5.2.2.6.

### 5.2.3.4 Channel coding for UCI channel quality information and HARQ-ACK

This section defines the channel coding scheme for the simultaneous transmission of channel quality information and HARQ-ACK information in a subframe.

When normal CP is used for uplink transmission, the channel quality information is coded according to section 5.2.3.3 with input bit sequence  $a'_0, a'_1, a'_2, a'_3, \dots, a'_{A'-1}$  and output bit sequence  $b'_0, b'_1, b'_2, b'_3, \dots, b'_{B'-1}$ , where  $B' = 20$ . The HARQ-ACK bits are denoted by  $a''_0$  in case one HARQ-ACK bit or  $a''_0, a''_1$  in case two HARQ-ACK bits are reported per subframe. Each positive acknowledgement (ACK) is encoded as a binary '1' and each negative acknowledgement (NACK) is encoded as a binary '0'.

The output of this channel coding block for normal CP is denoted by  $b_0, b_1, b_2, b_3, \dots, b_{B-1}$ , where

$$b_i = b'_i, i = 0, \dots, B' - 1$$

In case one HARQ-ACK bit is reported per subframe:

$$b_{B'} = a''_0 \text{ and } B = (B' + 1)$$

In case two HARQ-ACK bits are reported per subframe:

$$b_{B'} = a''_0, b_{B'+1} = a''_1 \text{ and } B = (B' + 2)$$

When extended CP is used for uplink transmission, the channel quality information and the HARQ-ACK bits are jointly coded. The HARQ-ACK bits are denoted by  $a''_0$  in case one HARQ-ACK bit or  $[a''_0, a''_1]$  in case two HARQ-ACK bits are reported per subframe.

The channel quality information denoted by  $a'_0, a'_1, a'_2, a'_3, \dots, a'_{A'-1}$  is multiplexed with the HARQ-ACK bits to yield the sequence  $a_0, a_1, a_2, a_3, \dots, a_{A-1}$  as follows

$$a_i = a'_i, i = 0, \dots, A' - 1$$

and

$$a_{A'} = a''_0 \text{ and } A = (A' + 1) \text{ in case one HARQ-ACK bit is reported per subframe, or}$$

$$a_{A'} = a''_0, a_{(A'+1)} = a''_1 \text{ and } A = (A' + 2) \text{ in case two HARQ-ACK bits are reported per subframe.}$$

The sequence  $a_0, a_1, a_2, a_3, \dots, a_{A-1}$  is encoded according to section 5.2.3.3 to yield the output bit sequence  $b_0, b_1, b_2, b_3, \dots, b_{B-1}$  where  $B = 20$ .

## 5.2.4 Uplink control information on PUSCH without UL-SCH data

When control data are sent via PUSCH without UL-SCH data, the following coding steps can be identified:

- Channel coding of control information
- Control information mapping
- Channel interleaver

### 5.2.4.1 Channel coding of control information

Control data arrives at the coding unit in the form of channel quality information (CQI and/or PMI), HARQ-ACK and rank indication. Different coding rates for the control information are achieved by allocating different number of coded symbols for its transmission. When the UE transmits HARQ-ACK bits or rank indicator bits, it shall determine the number of coded symbols  $Q'$  for HARQ-ACK or rank indicator as

$$Q' = \min \left( \left[ \frac{O \cdot M_{sc}^{PUSCH} \cdot N_{symb}^{PUSCH} \cdot \beta_{offset}^{PUSCH}}{O_{CQI-MIN}} \right], 4 \cdot M_{sc}^{PUSCH} \right)$$

where  $O$  is the number of HARQ-ACK bits as defined in section 5.2.2.6, or rank indicator bits,  $O_{CQI-MIN}$  is the number of CQI bits including CRC bits assuming rank equals to 1 for all serving cells for which an aperiodic CSI report is triggered [3],  $M_{sc}^{PUSCH}$  is the scheduled bandwidth for PUSCH transmission in the current subframe expressed as a number of subcarriers in [2], and  $N_{symb}^{PUSCH}$  is the number of SC-FDMA symbols in the current PUSCH transmission sub-frame given by  $N_{symb}^{PUSCH} = (2 \cdot (N_{symb}^{UL} - 1) - N_{SRS})$ , where  $N_{SRS}$  is equal to 1 if UE is configured to send PUSCH and SRS in the same subframe for the current subframe, or if the PUSCH resource allocation for the current subframe even partially overlaps with the cell-specific SRS subframe and bandwidth configuration defined in section 5.5.3 of [2], or if the current subframe is a UE-specific type-1 SRS subframe as defined in Section 8.2 of [3]. Otherwise  $N_{SRS}$  is equal to 0.

For HARQ-ACK information  $Q_{ACK} = Q_m \cdot Q'$  and  $[\beta_{offset}^{PUSCH} = \beta_{offset}^{HARQ-ACK} / \beta_{offset}^{CQI}]$ , where  $\beta_{offset}^{HARQ-ACK}$  shall be determined according to [3].

For rank indication  $Q_{RI} = Q_m \cdot Q'$  and  $[\beta_{offset}^{PUSCH} = \beta_{offset}^{RI} / \beta_{offset}^{CQI}]$ , where  $\beta_{offset}^{RI}$  shall be determined according to [3].

For CQI and/or PMI information  $Q_{CQI} = N_{symb}^{PUSCH} \cdot M_{sc}^{PUSCH} \cdot Q_m - Q_{RI}$ .

The channel coding and rate matching of the control data is performed according to section 5.2.2.6. The coded output sequence for channel quality information is denoted by  $q_0, q_1, q_2, q_3, \dots, q_{Q_{CQI}-1}$ , the coded vector sequence output for HARQ-ACK is denoted by  $\underline{q}_0^{ACK}, \underline{q}_1^{ACK}, \underline{q}_2^{ACK}, \dots, \underline{q}_{Q_{ACK}-1}^{ACK}$  and the coded vector sequence output for rank indication is denoted by  $\underline{q}_0^{RI}, \underline{q}_1^{RI}, \underline{q}_2^{RI}, \dots, \underline{q}_{Q_{RI}-1}^{RI}$ .

#### 5.2.4.2 Control information mapping

The input are the coded bits of the channel quality information denoted by  $q_0, q_1, q_2, q_3, \dots, q_{Q_{CQI}-1}$ . The output is denoted by  $\underline{g}_0, \underline{g}_1, \underline{g}_2, \underline{g}_3, \dots, \underline{g}_{H'-1}$ , where  $H = Q_{CQI}$  and  $H' = H / Q_m$ , and where  $\underline{g}_i, i = 0, \dots, H'-1$  are column vectors of length  $Q_m$ .  $H$  is the total number of coded bits allocated for CQI/PMI information.

The control information shall be mapped as follows:

Set  $j, k$  to 0

while  $j < Q_{CQI}$

$$\underline{g}_k = [q_j \dots q_{j+Q_m-1}]^T$$

$$j = j + Q_m$$

$$k = k + 1$$

end while

### 5.2.4.3 Channel interleaver

The vector sequences  $\underline{g}_0, \underline{g}_1, \underline{g}_2, \dots, \underline{g}_{H'-1}$ ,  $\underline{q}_0^{RI}, \underline{q}_1^{RI}, \underline{q}_2^{RI}, \dots, \underline{q}_{Q_{RI}-1}^{RI}$  and  $\underline{q}_0^{ACK}, \underline{q}_1^{ACK}, \underline{q}_2^{ACK}, \dots, \underline{q}_{Q_{ACK}-1}^{ACK}$  are channel interleaved according section 5.2.2.8. The bits after channel interleaving are denoted by  $h_0, h_1, h_2, \dots, h_{H+Q_{RI}-1}$ .

## 5.3 Downlink transport channels and control information

### 5.3.1 Broadcast channel

Figure 5.3.1-1 shows the processing structure for the BCH transport channel. Data arrives to the coding unit in the form of a maximum of one transport block every transmission time interval (TTI) of 40ms. The following coding steps can be identified:

- Add CRC to the transport block
- Channel coding
- Rate matching

The coding steps for BCH transport channel are shown in the figure below.

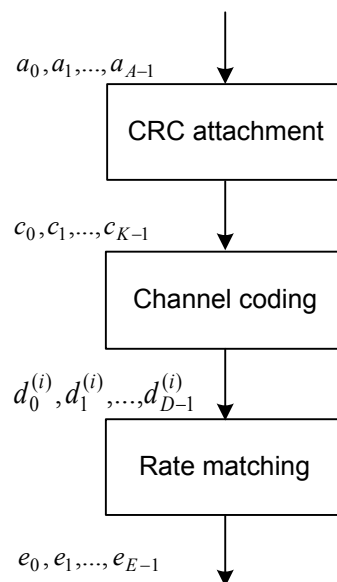

**Figure 5.3.1-1: Transport channel processing for BCH.**

#### 5.3.1.1 Transport block CRC attachment

Error detection is provided on BCH transport blocks through a Cyclic Redundancy Check (CRC).

The entire transport block is used to calculate the CRC parity bits. Denote the bits in a transport block delivered to layer 1 by  $a_0, a_1, a_2, a_3, \dots, a_{A-1}$ , and the parity bits by  $p_0, p_1, p_2, p_3, \dots, p_{L-1}$ .  $A$  is the size of the transport block and set to 24 bits and  $L$  is the number of parity bits. The lowest order information bit  $a_0$  is mapped to the most significant bit of the transport block as defined in section 6.1.1 of [5].

The parity bits are computed and attached to the BCH transport block according to section 5.1.1 setting  $L$  to 16 bits. After the attachment, the CRC bits are scrambled according to the eNodeB transmit antenna configuration with the sequence  $x_{ant,0}, x_{ant,1}, \dots, x_{ant,15}$  as indicated in Table 5.3.1.1-1 to form the sequence of bits  $c_0, c_1, c_2, c_3, \dots, c_{K-1}$  where

$$c_k = a_k \quad \text{for } k = 0, 1, 2, \dots, A-1$$

$$c_k = (p_{k-A} + x_{ant,k-A}) \bmod 2 \quad \text{for } k = A, A+1, A+2, \dots, A+15.$$

**Table 5.3.1.1-1: CRC mask for PBCH.**

Number of transmit antenna ports at eNodeB	PBCH CRC mask $\langle x_{ant,0}, x_{ant,1}, \dots, x_{ant,15} \rangle$
1	$\langle 0, 0, 0, 0, 0, 0, 0, 0, 0, 0, 0, 0, 0, 0, 0, 0 \rangle$
2	$\langle 1, 1, 1, 1, 1, 1, 1, 1, 1, 1, 1, 1, 1, 1, 1, 1 \rangle$
4	$\langle 0, 1, 0, 1, 0, 1, 0, 1, 0, 1, 0, 1, 0, 1, 0, 1 \rangle$

### 5.3.1.2 Channel coding

Information bits are delivered to the channel coding block. They are denoted by  $c_0, c_1, c_2, c_3, \dots, c_{K-1}$ , where  $K$  is the number of bits, and they are tail biting convolutionally encoded according to section 5.1.3.1.

After encoding the bits are denoted by  $d_0^{(i)}, d_1^{(i)}, d_2^{(i)}, d_3^{(i)}, \dots, d_{D-1}^{(i)}$ , with  $i = 0, 1, \text{ and } 2$ , and where  $D$  is the number of bits on the  $i$ -th coded stream, i.e.,  $D = K$ .

### 5.3.1.3 Rate matching

A tail biting convolutionally coded block is delivered to the rate matching block. This block of coded bits is denoted by  $d_0^{(i)}, d_1^{(i)}, d_2^{(i)}, d_3^{(i)}, \dots, d_{D-1}^{(i)}$ , with  $i = 0, 1, \text{ and } 2$ , and where  $i$  is the coded stream index and  $D$  is the number of bits in each coded stream. This coded block is rate matched according to section 5.1.4.2.

After rate matching, the bits are denoted by  $e_0, e_1, e_2, e_3, \dots, e_{E-1}$ , where  $E$  is the number of rate matched bits as defined in section 6.6.1 of [2].

## 5.3.2 Downlink shared channel, Paging channel and Multicast channel

Figure 5.3.2-1 shows the processing structure for each transport block for the DL-SCH, PCH and MCH transport channels. Data arrives to the coding unit in the form of a maximum of two transport blocks every transmission time interval (TTI) per DL cell. The following coding steps can be identified for each transport block of a DL cell:

- Add CRC to the transport block
- Code block segmentation and code block CRC attachment
- Channel coding
- Rate matching
- Code block concatenation

The coding steps for PCH and MCH transport channels, and for one transport block of DL-SCH are shown in the figure below. The same processing applies for each transport block on each DL cell.

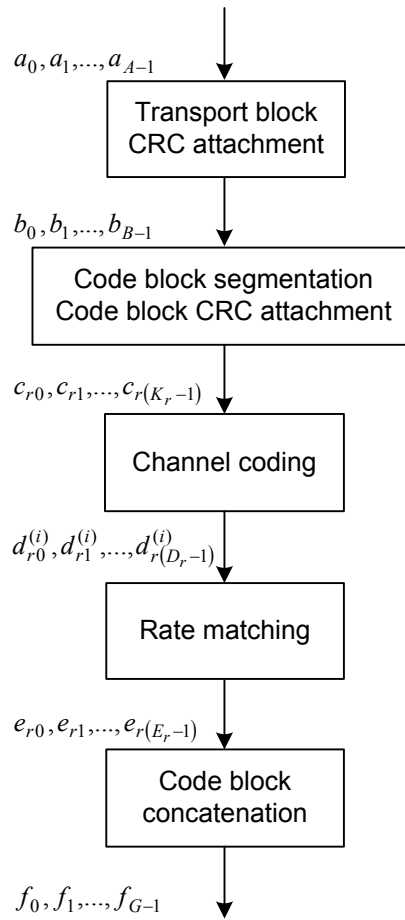

**Figure 5.3.2-1: Transport block processing for DL-SCH, PCH and MCH.**

### 5.3.2.1 Transport block CRC attachment

Error detection is provided on transport blocks through a Cyclic Redundancy Check (CRC).

The entire transport block is used to calculate the CRC parity bits. Denote the bits in a transport block delivered to layer 1 by  $a_0, a_1, a_2, a_3, \dots, a_{A-1}$ , and the parity bits by  $p_0, p_1, p_2, p_3, \dots, p_{L-1}$ .  $A$  is the size of the transport block and  $L$  is the number of parity bits. The lowest order information bit  $a_0$  is mapped to the most significant bit of the transport block as defined in section 6.1.1 of [5].

The parity bits are computed and attached to the transport block according to section 5.1.1 setting  $L$  to 24 bits and using the generator polynomial  $g_{\text{CRC24A}}(D)$ .

### 5.3.2.2 Code block segmentation and code block CRC attachment

The bits input to the code block segmentation are denoted by  $b_0, b_1, b_2, b_3, \dots, b_{B-1}$  where  $B$  is the number of bits in the transport block (including CRC).

Code block segmentation and code block CRC attachment are performed according to section 5.1.2.

The bits after code block segmentation are denoted by  $c_{r0}, c_{r1}, c_{r2}, c_{r3}, \dots, c_{r(K_r-1)}$ , where  $r$  is the code block number and  $K_r$  is the number of bits for code block number  $r$ .



### 5.3.2.3 Channel coding

Code blocks are delivered to the channel coding block. They are denoted by  $c_{r0}, c_{r1}, c_{r2}, c_{r3}, \dots, c_{r(K_r-1)}$ , where  $r$  is the code block number, and  $K_r$  is the number of bits in code block number  $r$ . The total number of code blocks is denoted by  $C$  and each code block is individually turbo encoded according to section 5.1.3.2.

After encoding the bits are denoted by  $d_{r0}^{(i)}, d_{r1}^{(i)}, d_{r2}^{(i)}, d_{r3}^{(i)}, \dots, d_{r(D_r-1)}^{(i)}$ , with  $i = 0, 1, \text{ and } 2$ , and where  $D_r$  is the number of bits on the  $i$ -th coded stream for code block number  $r$ , i.e.  $D_r = K_r + 4$ .

### 5.3.2.4 Rate matching

Turbo coded blocks are delivered to the rate matching block. They are denoted by  $d_{r0}^{(i)}, d_{r1}^{(i)}, d_{r2}^{(i)}, d_{r3}^{(i)}, \dots, d_{r(D_r-1)}^{(i)}$ , with  $i = 0, 1, \text{ and } 2$ , and where  $r$  is the code block number,  $i$  is the coded stream index, and  $D_r$  is the number of bits in each coded stream of code block number  $r$ . The total number of code blocks is denoted by  $C$  and each coded block is individually rate matched according to section 5.1.4.1.

After rate matching, the bits are denoted by  $e_{r0}, e_{r1}, e_{r2}, e_{r3}, \dots, e_{r(E_r-1)}$ , where  $r$  is the coded block number, and where  $E_r$  is the number of rate matched bits for code block number  $r$ .

### 5.3.2.5 Code block concatenation

The bits input to the code block concatenation block are denoted by  $e_{r0}, e_{r1}, e_{r2}, e_{r3}, \dots, e_{r(E_r-1)}$  for  $r = 0, \dots, C-1$  and where  $E_r$  is the number of rate matched bits for the  $r$ -th code block.

Code block concatenation is performed according to section 5.1.5.

The bits after code block concatenation are denoted by  $f_0, f_1, f_2, f_3, \dots, f_{G-1}$ , where  $G$  is the total number of coded bits for transmission. This sequence of coded bits corresponding to one transport block after code block concatenation is referred to as one codeword in section 6.3.1 of [2]. In case of multiple transport blocks per TTI, the transport block to codeword mapping is specified according to section 5.3.3.1.5, 5.3.3.1.5A or 5.3.3.1.5B, depending on the DCI Format.

## 5.3.3 Downlink control information

A DCI transports downlink or uplink scheduling information, requests for aperiodic CQI reports, notifications of MCCH change [6] or uplink power control commands for one cell and one RNTI. The RNTI is implicitly encoded in the CRC.

Figure 5.3.3-1 shows the processing structure for one DCI. The following coding steps can be identified:

- Information element multiplexing
- CRC attachment
- Channel coding
- Rate matching

The coding steps for DCI are shown in the figure below.

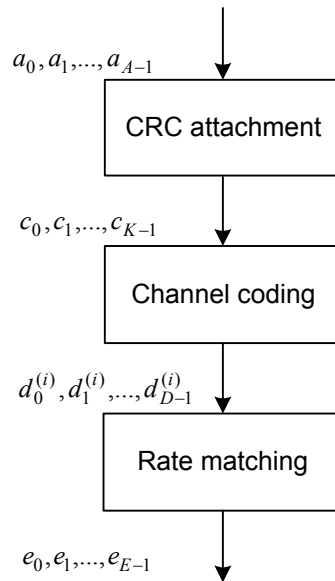

**Figure 5.3.3-1: Processing for one DCI.**

### 5.3.3.1 DCI formats

The fields defined in the DCI formats below are mapped to the information bits  $a_0$  to  $a_{A-1}$  as follows.

Each field is mapped in the order in which it appears in the description, including the zero-padding bit(s), if any, with the first field mapped to the lowest order information bit  $a_0$  and each successive field mapped to higher order information bits. The most significant bit of each field is mapped to the lowest order information bit for that field, e.g. the most significant bit of the first field is mapped to  $a_0$ .

#### 5.3.3.1.1 Format 0

DCI format 0 is used for the scheduling of PUSCH in one UL cell.

The following information is transmitted by means of the DCI format 0:

- Carrier indicator – 0 or 3 bits. This field is present according to the definitions in [3].
- Flag for format0/format1A differentiation – 1 bit, where value 0 indicates format 0 and value 1 indicates format 1A
- Frequency hopping flag – 1 bit as defined in section 8.4 of [3]. This field is used as the MSB of the corresponding resource allocation field for resource allocation type 1.
- Resource block assignment and hopping resource allocation –  $\left\lceil \log_2(N_{RB}^{UL}(N_{RB}^{UL} + 1)/2) \right\rceil$  bits
  - For PUSCH hopping (resource allocation type 0 only):
    - $N_{UL\_hop}$  MSB bits are used to obtain the value of  $\tilde{n}_{PRB}(i)$  as indicated in section 8.4 of [3]
    - $\left( \left\lceil \log_2(N_{RB}^{UL}(N_{RB}^{UL} + 1)/2) \right\rceil - N_{UL\_hop} \right)$  bits provide the resource allocation of the first slot in the UL subframe
  - For non-hopping PUSCH with resource allocation type 0:
    - $\left( \left\lceil \log_2(N_{RB}^{UL}(N_{RB}^{UL} + 1)/2) \right\rceil \right)$  bits provide the resource allocation in the UL subframe as defined in section 8.1.1 of [3]
  - For non-hopping PUSCH with resource allocation type 1:

- The concatenation of the frequency hopping flag field and the resource block assignment and hopping resource allocation field provides the resource allocation field in the UL subframe as defined in section 8.1.2 of [3]
- Modulation and coding scheme and redundancy version – 5 bits as defined in section 8.6 of [3]
- New data indicator – 1 bit
- TPC command for scheduled PUSCH – 2 bits as defined in section 5.1.1.1 of [3]
- Cyclic shift for DM RS and OCC index – 3 bits as defined in section 5.5.2.1.1 of [2]
- UL index – 2 bits as defined in sections 5.1.1.1, 7.2.1, 8 and 8.4 of [3] (this field is present only for TDD operation with uplink-downlink configuration 0)
- Downlink Assignment Index (DAI) – 2 bits as defined in section 7.3 of [3] (this field is present only for TDD operation with uplink-downlink configurations 1-6)
- CSI request – 1 or 2 bits as defined in section 7.2.1 of [3]. The 2-bit field applies to UEs that are configured with more than one DL cell and when the corresponding DCI format is mapped onto the UE specific search space given by the C-RNTI as defined in [3]; otherwise the 1-bit field applies
- SRS request – 0 or 1 bit. This field can only be present in DCI formats scheduling PUSCH which are mapped onto the UE specific search space given by the C-RNTI as defined in [3]. The interpretation of this field is provided in section 8.2 of [3]
- Resource allocation type – 1 bit. This field is only present if  $N_{RB}^{UL} \leq N_{RB}^{DL}$ . The interpretation of this field is provided in section 8.1 of [3]

If the number of information bits in format 0 mapped onto a given search space is less than the payload size of format 1A for scheduling the same serving cell and mapped onto the same search space (including any padding bits appended to format 1A), zeros shall be appended to format 0 until the payload size equals that of format 1A.

### 5.3.3.1.2 Format 1

DCI format 1 is used for the scheduling of one PDSCH codeword in one cell.

The following information is transmitted by means of the DCI format 1:

- Carrier indicator – 0 or 3 bits. This field is present according to the definitions in [3].
- Resource allocation header (resource allocation type 0 / type 1) – 1 bit as defined in section 7.1.6 of [3]
  - If downlink bandwidth is less than or equal to 10 PRBs, there is no resource allocation header and resource allocation type 0 is assumed.
- Resource block assignment:
  - For resource allocation type 0 as defined in section 7.1.6.1 of [3]:
    - $\lceil N_{RB}^{DL} / P \rceil$  bits provide the resource allocation
  - For resource allocation type 1 as defined in section 7.1.6.2 of [3]:
    - $\lceil \log_2(P) \rceil$  bits of this field are used as a header specific to this resource allocation type to indicate the selected resource blocks subset
    - 1 bit indicates a shift of the resource allocation span
    - $\left( \lceil N_{RB}^{DL} / P \rceil - \lceil \log_2(P) \rceil - 1 \right)$  bits provide the resource allocation

where the value of P depends on the number of DL resource blocks as indicated in section 7.1.6.1 of [3]

- Modulation and coding scheme – 5 bits as defined in section 7.1.7 of [3]

- HARQ process number – 3 bits (FDD), 4 bits (TDD)
- New data indicator – 1 bit
- Redundancy version – 2 bits
- TPC command for PUCCH – 2 bits as defined in section 5.1.2.1 of [3]
- Downlink Assignment Index (this field is present in TDD for all the uplink –downlink configurations and only applies to TDD operation with uplink –downlink configuration 1-6. This field is not present in FDD) – 2 bits

If the UE is not configured to decode PDCCH with CRC scrambled by the C-RNTI and the number of information bits in format 1 is equal to that for format 0/1A, one bit of value zero shall be appended to format 1.

If the UE is configured to decode PDCCH with CRC scrambled by the C-RNTI and the number of information bits in format 1 is equal to that for format 0/1A for scheduling the same serving cell and mapped onto the UE specific search space given by the C-RNTI as defined in [3], one bit of value zero shall be appended to format 1.

If the number of information bits in format 1 belongs to one of the sizes in Table 5.3.3.1.2-1, one or more zero bit(s) shall be appended to format 1 until the payload size of format 1 does not belong to one of the sizes in Table 5.3.3.1.2-1 and is not equal to that of format 0/1A mapped onto the same search space.

**Table 5.3.3.1.2-1: Ambiguous Sizes of Information Bits.**

{12, 14, 16, 20, 24, 26, 32, 40, 44, 56}
--

### 5.3.3.1.3 Format 1A

DCI format 1A is used for the compact scheduling of one PDSCH codeword in one cell and random access procedure initiated by a PDCCH order.

The following information is transmitted by means of the DCI format 1A:

- Carrier indicator – 0 or 3 bits. This field is present according to the definitions in [3].
- Flag for format0/format1A differentiation – 1 bit, where value 0 indicates format 0 and value 1 indicates format 1A

Format 1A is used for random access procedure initiated by a PDCCH order only if format 1A CRC is scrambled with C-RNTI and all the remaining fields are set as follows:

- Localized/Distributed VRB assignment flag – 1 bit is set to ‘0’
- Resource block assignment –  $\lceil \log_2(N_{RB}^{DL}(N_{RB}^{DL} + 1)/2) \rceil$  bits, where all bits shall be set to 1
- Preamble Index – 6 bits
- PRACH Mask Index – 4 bits, [5]
- All the remaining bits in format 1A for compact scheduling assignment of one PDSCH codeword are set to zero

Otherwise,

- Localized/Distributed VRB assignment flag – 1 bit as defined in 7.1.6.3 of [3]
- Resource block assignment –  $\lceil \log_2(N_{RB}^{DL}(N_{RB}^{DL} + 1)/2) \rceil$  bits as defined in section 7.1.6.3 of [3]:

- For localized VRB:

$$\lceil \log_2(N_{RB}^{DL}(N_{RB}^{DL} + 1)/2) \rceil \text{ bits provide the resource allocation}$$

- For distributed VRB:

- If  $N_{RB}^{DL} < 50$  or if the format 1A CRC is scrambled by RA-RNTI, P-RNTI, or SI-RNTI
  - $\lceil \log_2(N_{RB}^{DL}(N_{RB}^{DL} + 1)/2) \rceil$  bits provide the resource allocation
- Else
  - 1 bit, the MSB indicates the gap value, where value 0 indicates  $N_{gap} = N_{gap,1}$  and value 1 indicates  $N_{gap} = N_{gap,2}$
  - $(\lceil \log_2(N_{RB}^{DL}(N_{RB}^{DL} + 1)/2) \rceil - 1)$  bits provide the resource allocation,

where  $N_{gap}$  is defined in [2].

- Modulation and coding scheme – 5bits as defined in section 7.1.7 of [3]
- HARQ process number – 3 bits (FDD) , 4 bits (TDD)
- New data indicator – 1 bit
  - If the format 1A CRC is scrambled by RA-RNTI, P-RNTI, or SI-RNTI:
    - If  $N_{RB}^{DL} \geq 50$  and Localized/Distributed VRB assignment flag is set to 1
      - the new data indicator bit indicates the gap value, where value 0 indicates  $N_{gap} = N_{gap,1}$  and value 1 indicates  $N_{gap} = N_{gap,2}$ .
    - Else the new data indicator bit is reserved.
  - Else
    - The new data indicator bit as defined in [5]
- Redundancy version – 2 bits
- TPC command for PUCCH – 2 bits as defined in section 5.1.2.1 of [3]
  - If the format 1A CRC is scrambled by RA-RNTI, P-RNTI, or SI-RNTI:
    - The most significant bit of the TPC command is reserved.
    - The least significant bit of the TPC command indicates column  $N_{PRB}^{1A}$  of the TBS table defined of [3].
    - If least significant bit is 0 then  $N_{PRB}^{1A} = 2$  else  $N_{PRB}^{1A} = 3$ .
  - Else
    - The two bits including the most significant bit indicates the TPC command
- Downlink Assignment Index (this field is present in TDD for all the uplink –downlink configurations and only applies to TDD operation with uplink –downlink configuration 1-6. This field is not present in FDD) – 2 bits
- SRS request – 0 or 1 bit. This field can only be present in DCI formats scheduling PDSCH which are mapped onto the UE specific search space given by the C-RNTI as defined in [3]. The interpretation of this field is provided in section 8.2 of [3]

If the UE is not configured to decode PDCCH with CRC scrambled by the C-RNTI, and the number of information bits in format 1A is less than that of format 0, zeros shall be appended to format 1A until the payload size equals that of format 0.

If the UE is configured to decode PDCCH with CRC scrambled by the C-RNTI and the number of information bits in format 1A mapped onto a given search space is less than that of format 0 for scheduling the same serving cell and

mapped onto the same search space, zeros shall be appended to format 1A until the payload size equals that of format 0, except when format 1A assigns downlink resource on a secondary cell without an uplink configuration associated with the secondary cell.

If the number of information bits in format 1A belongs to one of the sizes in Table 5.3.3.1.2-1, one zero bit shall be appended to format 1A.

When the format 1A CRC is scrambled with a RA-RNTI, P-RNTI, or SI-RNTI then the following fields among the fields above are reserved:

- HARQ process number
- Downlink Assignment Index (used for TDD only and is not present in FDD)

### 5.3.3.1.3A Format 1B

DCI format 1B is used for the compact scheduling of one PDSCH codeword in one cell with precoding information.

The following information is transmitted by means of the DCI format 1B:

- Carrier indicator – 0 or 3 bits. The field is present according to the definitions in [3].
- Localized/Distributed VRB assignment flag – 1 bit as defined in section 7.1.6.3 of [3]
- Resource block assignment –  $\left\lceil \log_2(N_{RB}^{DL}(N_{RB}^{DL} + 1)/2) \right\rceil$  bits as defined in section 7.1.6.3 of [3]
  - For localized VRB:
    - $\left\lceil \log_2(N_{RB}^{DL}(N_{RB}^{DL} + 1)/2) \right\rceil$  bits provide the resource allocation
  - For distributed VRB:
    - For  $N_{RB}^{DL} < 50$ 
      - $\left\lceil \log_2(N_{RB}^{DL}(N_{RB}^{DL} + 1)/2) \right\rceil$  bits provide the resource allocation
    - For  $N_{RB}^{DL} \geq 50$ 
      - 1 bit, the MSB indicates the gap value, where value 0 indicates  $N_{gap} = N_{gap,1}$  and value 1 indicates  $N_{gap} = N_{gap,2}$
      - $(\left\lceil \log_2(N_{RB}^{DL}(N_{RB}^{DL} + 1)/2) \right\rceil - 1)$  bits provide the resource allocation
- Modulation and coding scheme – 5bits as defined in section 7.1.7 of [3]
- HARQ process number – 3 bits (FDD) , 4 bits (TDD)
- New data indicator – 1 bit
- Redundancy version – 2 bits
- TPC command for PUCCH – 2 bits as defined in section 5.1.2.1 of [3]
- Downlink Assignment Index (this field is present in TDD for all the uplink –downlink configurations and only applies to TDD operation with uplink –downlink configuration 1-6. This field is not present in FDD) – 2 bits
- TPMI information for precoding – number of bits as specified in Table 5.3.3.1.3A-1
  - TPMI information indicates which codebook index is used in Table 6.3.4.2.3-1 or Table 6.3.4.2.3-2 of [2] corresponding to the single-layer transmission.

- PMI confirmation for precoding – 1 bit as specified in Table 5.3.3.1.3A-2

If PMI confirmation indicates that the eNodeB has applied precoding according to PMI(s) reported by the UE, the precoding for the corresponding RB(s) in subframe  $n$  is according to the latest PMI(s) in an aperiodic CSI reported on or before subframe  $n-4$ .

**Table 5.3.3.1.3A-1: Number of bits for TPMI information.**

Number of antenna ports at eNodeB	Number of bits
2	2
4	4

**Table 5.3.3.1.3A-2: Content of PMI confirmation.**

Bit field mapped to index	Message
0	Precoding according to the indicated TPMI in the TPMI information field
1	<p>Precoding using the precoder(s) according to PMI(s) indicated in the latest aperiodic CSI report.</p> <p>For aperiodic CSI mode 2-2:</p> <ul style="list-style-type: none"> <li>- Precoding of scheduled resource blocks belonging to the reported preferred M subband(s), use precoder(s) according to the preferred M subband PMI(s) indicated in the latest aperiodic CSI report;</li> <li>- Precoding of scheduled resource blocks not belonging to the reported preferred M subband(s), precoding using a precoder according to the wideband PMI indicated in the latest aperiodic CSI report.</li> </ul>

If the number of information bits in format 1B is equal to that for format 0/1A for scheduling the same serving cell and mapped onto the UE specific search space given by the C-RNTI as defined in [3], one bit of value zero shall be appended to format 1B.

If the number of information bits in format 1B belongs to one of the sizes in Table 5.3.3.1.2-1, one or more zero bit(s) shall be appended to format 1B until the payload size of format 1B does not belong to one of the sizes in Table 5.3.3.1.2-1 and is not equal to that of format 0/1A mapped onto the same search space.

#### 5.3.3.1.4 Format 1C

DCI format 1C is used for very compact scheduling of one PDSCH codeword and notifying MCCH change [6].

The following information is transmitted by means of the DCI format 1C:

If the format 1C is used for very compact scheduling of one PDSCH codeword

- 1 bit indicates the gap value, where value 0 indicates  $N_{\text{gap}} = N_{\text{gap},1}$  and value 1 indicates  $N_{\text{gap}} = N_{\text{gap},2}$
- For  $N_{\text{RB}}^{\text{DL}} < 50$ , there is no bit for gap indication
- Resource block assignment –  $\left\lceil \log_2 \left( \left\lfloor N_{\text{VRB,gap1}}^{\text{DL}} / N_{\text{RB}}^{\text{step}} \right\rfloor \cdot \left( \left\lfloor N_{\text{VRB,gap1}}^{\text{DL}} / N_{\text{RB}}^{\text{step}} \right\rfloor + 1 \right) / 2 \right) \right\rceil$  bits as defined in 7.1.6.3 of [3] where  $N_{\text{VRB,gap1}}^{\text{DL}}$  is defined in [2] and  $N_{\text{RB}}^{\text{step}}$  is defined in [3]
- Modulation and coding scheme – 5 bits as defined in section 7.1.7 of [3]

Else

- Information for MCCH change notification – 8 bits as defined in section 5.8.1.3 of [6]
- Reserved information bits are added until the size is equal to that of format 1C used for very compact scheduling of one PDSCH codeword

### 5.3.3.1.4A Format 1D

DCI format 1D is used for the compact scheduling of one PDSCH codeword in one cell with precoding and power offset information.

The following information is transmitted by means of the DCI format 1D:

- Carrier indicator – 0 or 3 bits. The field is present according to the definitions in [3].
- Localized/Distributed VRB assignment flag – 1 bit as defined in section 7.1.6.3 of [3]
- Resource block assignment –  $\lceil \log_2(N_{RB}^{DL}(N_{RB}^{DL} + 1)/2) \rceil$  bits as defined in section 7.1.6.3 of [3]:
  - For localized VRB:
    - $\lceil \log_2(N_{RB}^{DL}(N_{RB}^{DL} + 1)/2) \rceil$  bits provide the resource allocation
  - For distributed VRB:
    - For  $N_{RB}^{DL} < 50$ 
      - $\lceil \log_2(N_{RB}^{DL}(N_{RB}^{DL} + 1)/2) \rceil$  bits provide the resource allocation
    - For  $N_{RB}^{DL} \geq 50$ 
      - 1 bit, the MSB indicates the gap value, where value 0 indicates  $N_{gap} = N_{gap,1}$  and value 1 indicates  $N_{gap} = N_{gap,2}$
      - $(\lceil \log_2(N_{RB}^{DL}(N_{RB}^{DL} + 1)/2) \rceil - 1)$  bits provide the resource allocation
- Modulation and coding scheme – 5bits as defined in section 7.1.7 of [3]
- HARQ process number – 3 bits (FDD), 4 bits (TDD)
- New data indicator – 1 bit
- Redundancy version – 2 bits
- TPC command for PUCCH – 2 bits as defined in section 5.1.2.1 of [3]
- Downlink Assignment Index (this field is present in TDD for all the uplink –downlink configurations and only applies to TDD operation with uplink –downlink configuration 1-6. This field is not present in FDD) – 2 bits
- TPMI information for precoding – number of bits as specified in Table 5.3.3.1.4A-1
  - TPMI information indicates which codebook index is used in Table 6.3.4.2.3-1 or Table 6.3.4.2.3-2 of [2] corresponding to the single-layer transmission.
- Downlink power offset – 1 bit as defined in section 7.1.5 of [3]

**Table 5.3.3.1.4A-1: Number of bits for TPMI information.**

Number of antenna ports at eNodeB	Number of bits
2	2
4	4



If the number of information bits in format 1D is equal to that for format 0/1A for scheduling the same serving cell and mapped onto the UE specific search space given by the C-RNTI as defined in [3], one bit of value zero shall be appended to format 1D.

If the number of information bits in format 1D belongs to one of the sizes in Table 5.3.3.1.2-1, one or more zero bit(s) shall be appended to format 1D until the payload size of format 1D does not belong to one of the sizes in Table 5.3.3.1.2-1 and is not equal to that of format 0/1A mapped onto the same search space.

### 5.3.3.1.5 Format 2

The following information is transmitted by means of the DCI format 2:

- Carrier indicator – 0 or 3 bits. The field is present according to the definitions in [3].
- Resource allocation header (resource allocation type 0 / type 1) – 1 bit as defined in section 7.1.6 of [3]

If downlink bandwidth is less than or equal to 10 PRBs, there is no resource allocation header and resource allocation type 0 is assumed.

- Resource block assignment:

- For resource allocation type 0 defined in section 7.1.6.1 of [3]:

- $\lceil N_{\text{RB}}^{\text{DL}} / P \rceil$  bits provide the resource allocation

- For resource allocation type 1 as defined in section 7.1.6.2 of [3]:

- $\lceil \log_2(P) \rceil$  bits of this field are used as a header specific to this resource allocation type to indicate the selected resource blocks subset

- 1 bit indicates a shift of the resource allocation span

- $\left( \lceil N_{\text{RB}}^{\text{DL}} / P \rceil - \lceil \log_2(P) \rceil - 1 \right)$  bits provide the resource allocation

where the value of P depends on the number of DL resource blocks as indicated in section 7.1.6.1 of [3]

- TPC command for PUCCH – 2 bits as defined in section 5.1.2.1 of [3]
- Downlink Assignment Index (this field is present in TDD for all the uplink –downlink configurations and only applies to TDD operation with uplink –downlink configuration 1-6. This field is not present in FDD) – 2 bits
- HARQ process number - 3 bits (FDD), 4 bits (TDD)
- Transport block to codeword swap flag – 1 bit

In addition, for transport block 1:

- Modulation and coding scheme – 5 bits as defined in section 7.1.7 of [3]
- New data indicator – 1 bit
- Redundancy version – 2 bits

In addition, for transport block 2:

- Modulation and coding scheme – 5 bits as defined in section 7.1.7 of [3]
- New data indicator – 1 bit
- Redundancy version – 2 bits

Precoding information – number of bits as specified in Table 5.3.3.1.5-3

If both transport blocks are enabled, the transport block to codeword mapping is specified according to Table 5.3.3.1.5-1.

In case one of the transport blocks is disabled as specified in section 7.1.7.2 of [3], the transport block to codeword swap flag is reserved and the transport block to codeword mapping is specified according to Table 5.3.3.1.5-2.

**Table 5.3.3.1.5-1: Transport block to codeword mapping (two transport blocks enabled).**

transport block to codeword swap flag value	codeword 0 (enabled)	codeword 1 (enabled)
0	transport block 1	transport block 2
1	transport block 2	transport block 1

**Table 5.3.3.1.5-2: Transport block to codeword mapping (one transport block enabled).**

transport block 1	transport block 2	codeword 0 (enabled)	codeword 1 (disabled)
enabled	disabled	transport block 1	-
disabled	enabled	transport block 2	-

The interpretation of the precoding information field depends on the number of enabled codewords according to Table 5.3.3.1.5-4 and Table 5.3.3.1.5-5. Note that TPMI indicates which codebook index is used in Table 6.3.4.2.3-1 or Table 6.3.4.2.3-2 of [2]. For a single enabled codeword, indices 18 to 34 inclusive in Table 5.3.3.1.5-5 are only supported for retransmission of the corresponding transport block if that transport block has previously been transmitted using two layers with closed-loop spatial multiplexing.

If the number of information bits in format 2 belongs to one of the sizes in Table 5.3.3.1.2-1, one zero bit shall be appended to format 2.

Some entries in Table 5.3.3.1.5-4 and Table 5.3.3.1.5-5 are used for indicating that the eNodeB has applied precoding according to PMI(s) reported by the UE. In these cases the precoding for the corresponding RB(s) in subframe  $n$  is according to the latest PMI(s) in an aperiodic CSI reported on or before subframe  $n-4$ . For aperiodic CSI mode 2-2: Precoding of scheduled resource blocks belonging to the reported preferred M subband(s) use precoder(s) according to the preferred M subband PMI indicated by the latest aperiodic CSI report; Precoding of scheduled resource blocks not belonging to the reported preferred M subband(s) use a precoder according to the wideband PMI indicated by the latest aperiodic CSI report.

**Table 5.3.3.1.5-3: Number of bits for precoding information.**

Number of antenna ports at eNodeB	Number of bits for precoding information
2	3
4	6

Table 5.3.3.1.5-4: Content of precoding information field for 2 antenna ports.

One codeword: Codeword 0 enabled, Codeword 1 disabled		Two codewords: Codeword 0 enabled, Codeword 1 enabled	
Bit field mapped to index	Message	Bit field mapped to index	Message
0	2 layers: Transmit diversity	0	2 layers: Precoding corresponding to precoder matrix $\frac{1}{2} \begin{bmatrix} 1 & 1 \\ 1 & -1 \end{bmatrix}$
1	1 layer: Precoding corresponding to precoding vector $[1 \ 1]^T / \sqrt{2}$	1	2 layers: Precoding corresponding to precoder matrix $\frac{1}{2} \begin{bmatrix} 1 & 1 \\ j & -j \end{bmatrix}$
2	1 layer: Precoding corresponding to precoder vector $[1 \ -1]^T / \sqrt{2}$	2	2 layers: Precoding according to the latest PMI report on PUSCH, using the precoder(s) indicated by the reported PMI(s)
3	1 layer: Precoding corresponding to precoder vector $[1 \ j]^T / \sqrt{2}$	3	reserved
4	1 layer: Precoding corresponding to precoder vector $[1 \ -j]^T / \sqrt{2}$	4	reserved
5	1 layer: Precoding according to the latest PMI report on PUSCH, using the precoder(s) indicated by the reported PMI(s), if RI=2 was reported, using 1 <sup>st</sup> column  multiplied by $\sqrt{2}$ of all precoders implied by the reported PMI(s)	5	reserved
6	1 layer: Precoding according to the latest PMI report on PUSCH, using the precoder(s) indicated by the reported PMI(s), if RI=2 was reported, using 2 <sup>nd</sup> column  multiplied by $\sqrt{2}$ of all precoders implied by the reported PMI(s)	6	reserved
7	reserved	7	reserved

Table 5.3.3.1.5-5: Content of precoding information field for 4 antenna ports.

One codeword: Codeword 0 enabled, Codeword 1 disabled		Two codewords: Codeword 0 enabled, Codeword 1 enabled	
Bit field mapped to index	Message	Bit field mapped to index	Message
0	4 layers: Transmit diversity	0	2 layers: TPMI=0
1	1 layer: TPMI=0	1	2 layers: TPMI=1
2	1 layer: TPMI=1	⋮	⋮
⋮	⋮	15	2 layers: TPMI=15
16	1 layer: TPMI=15	16	2 layers: Precoding according to the latest PMI report on PUSCH using the precoder(s) indicated by the reported PMI(s)
17	1 layer: Precoding according to the latest PMI report on PUSCH using the precoder(s) indicated by the reported PMI(s)	17	3 layers: TPMI=0
18	2 layers: TPMI=0	18	3 layers: TPMI=1
19	2 layers: TPMI=1	⋮	⋮
⋮	⋮	32	3 layers: TPMI=15
33	2 layers: TPMI=15	33	3 layers: Precoding according to the latest PMI report on PUSCH using the precoder(s) indicated by the reported PMI(s)
34	2 layers: Precoding according to the latest PMI report on PUSCH using the precoder(s) indicated by the reported PMI(s)	34	4 layers: TPMI=0
35 – 63	reserved	35	4 layers: TPMI=1
		⋮	⋮
		49	4 layers: TPMI=15
		50	4 layers: Precoding according to the latest PMI report on PUSCH using the precoder(s) indicated by the reported PMI(s)
		51 – 63	Reserved

## 5.3.3.1.5A Format 2A

The following information is transmitted by means of the DCI format 2A:

- Carrier indicator – 0 or 3 bits. The field is present according to the definitions in [3].

- Resource allocation header (resource allocation type 0 / type 1) – 1 bit as defined in section 7.1.6 of [3]

If downlink bandwidth is less than or equal to 10 PRBs, there is no resource allocation header and resource allocation type 0 is assumed.

- Resource block assignment:

- For resource allocation type 0 as defined in section 7.1.6.1 of [3]

- $\lceil N_{RB}^{DL} / P \rceil$  bits provide the resource allocation

- For resource allocation type 1 as defined in section 7.1.6.2 of [3]

- $\lceil \log_2(P) \rceil$  bits of this field are used as a header specific to this resource allocation type to indicate the selected resource blocks subset

- 1 bit indicates a shift of the resource allocation span

- $\left( \lceil N_{RB}^{DL} / P \rceil - \lceil \log_2(P) \rceil - 1 \right)$  bits provide the resource allocation

where the value of P depends on the number of DL resource blocks as indicated in section 7.1.6.1 of [3]

- TPC command for PUCCH – 2 bits as defined in section 5.1.2.1 of [3]
- Downlink Assignment Index (this field is present in TDD for all the uplink –downlink configurations and only applies to TDD operation with uplink –downlink configuration 1-6. This field is not present in FDD) – 2 bits
- HARQ process number - 3 bits (FDD), 4 bits (TDD)
- Transport block to codeword swap flag – 1 bit

In addition, for transport block 1:

- Modulation and coding scheme – 5 bits as defined in section 7.1.7 of [3]
- New data indicator – 1 bit
- Redundancy version – 2 bits

In addition, for transport block 2:

- Modulation and coding scheme – 5 bits as defined in section 7.1.7 of [3]
- New data indicator – 1 bit
- Redundancy version – 2 bits

Precoding information – number of bits as specified in Table 5.3.3.1.5A-1

If both transport blocks are enabled, the transport block to codeword mapping is specified according to Table 5.3.3.1.5-1.

In case one of the transport blocks is disabled, the transport block to codeword swap flag is reserved and the transport block to codeword mapping is specified according to Table 5.3.3.1.5-2.

The precoding information field is defined according to Table 5.3.3.1.5A-2. For a single enabled codeword, index 1 in Table 5.3.3.1.5A-2 is only supported for retransmission of the corresponding transport block if that transport block has previously been transmitted using two layers with large delay CDD.

For transmission with 2 antenna ports, the precoding information field is not present. The number of transmission layers is equal to 2 if both codewords are enabled; transmit diversity is used if codeword 0 is enabled while codeword 1 is disabled.

If the number of information bits in format 2A belongs to one of the sizes in Table 5.3.3.1.2-1, one zero bit shall be appended to format 2A.

**Table 5.3.3.1.5A-1: Number of bits for precoding information.**

Number of antenna ports at eNodeB	Number of bits for precoding information
2	0
4	2

**Table 5.3.3.1.5A-2: Content of precoding information field for 4 antenna ports.**

One codeword: Codeword 0 enabled, Codeword 1 disabled		Two codewords: Codeword 0 enabled, Codeword 1 enabled	
Bit field mapped to index	Message	Bit field mapped to index	Message
0	4 layers: Transmit diversity	0	2 layers: precoder cycling with large delay CDD
1	2 layers: precoder cycling with large delay CDD	1	3 layers: precoder cycling with large delay CDD
2	reserved	2	4 layers: precoder cycling with large delay CDD
3	reserved	3	reserved

### 5.3.3.1.5B Format 2B

The following information is transmitted by means of the DCI format 2B:

- Carrier indicator – 0 or 3 bits. The field is present according to the definitions in [3].
- Resource allocation header (resource allocation type 0 / type 1) – 1 bit as defined in section 7.1.6 of [3]

If downlink bandwidth is less than or equal to 10 PRBs, there is no resource allocation header and resource allocation type 0 is assumed.

- Resource block assignment:

- For resource allocation type 0 as defined in section 7.1.6.1 of [3]

-  $\lceil N_{RB}^{DL} / P \rceil$  bits provide the resource allocation

- For resource allocation type 1 as defined in section 7.1.6.2 of [3]

-  $\lceil \log_2(P) \rceil$  bits of this field are used as a header specific to this resource allocation type to indicate the selected resource blocks subset

- 1 bit indicates a shift of the resource allocation span

-  $\left( \lceil N_{RB}^{DL} / P \rceil - \lceil \log_2(P) \rceil - 1 \right)$  bits provide the resource allocation

where the value of P depends on the number of DL resource blocks as indicated in section [7.1.6.1] of [3]

- TPC command for PUCCH – 2 bits as defined in section 5.1.2.1 of [3]
- Downlink Assignment Index (this field is present in TDD for all the uplink –downlink configurations and only applies to TDD operation with uplink –downlink configuration 1-6. This field is not present in FDD) – 2 bits

- HARQ process number - 3 bits (FDD), 4 bits (TDD)
- Scrambling identity – 1 bit as defined in section 6.10.3.1 of [2]
- SRS request – [0-1] bit. This field can only be present for TDD and if present is defined in section 8.2 of [3]

In addition, for transport block 1:

- Modulation and coding scheme – 5 bits as defined in section 7.1.7 of [3]
- New data indicator – 1 bit
- Redundancy version – 2 bits

In addition, for transport block 2:

- Modulation and coding scheme – 5 bits as defined in section 7.1.7 of [3]
- New data indicator – 1 bit
- Redundancy version – 2 bits

If both transport blocks are enabled, the number of layers equals two; transport block 1 is mapped to codeword 0; and transport block 2 is mapped to codeword 1. Antenna ports 7 and 8 are used for spatial multiplexing.

In case one of the transport blocks is disabled, the number of layers equals one; the transport block to codeword mapping is specified according to Table 5.3.3.1.5B-2; and the antenna port for single-antenna port transmission is according to Table 5.3.3.1.5B-1.

**Table 5.3.3.1.5B-1: Antenna port for single-antenna port transmission (one transport block disabled).**

New data indicator of the disabled transport block	Antenna port
0	7
1	8

If the number of information bits in format 2B belongs to one of the sizes in Table 5.3.3.1.2-1, one zero bit shall be appended to format 2B.

### 5.3.3.1.5C Format 2C

The following information is transmitted by means of the DCI format 2C:

- Carrier indicator – 0 or 3 bits. The field is present according to the definitions in [3].
- Resource allocation header (resource allocation type 0 / type 1) – 1 bit as defined in section 7.1.6 of [3]

If downlink bandwidth is less than or equal to 10 PRBs, there is no resource allocation header and resource allocation type 0 is assumed.

- Resource block assignment:

- For resource allocation type 0 as defined in section 7.1.6.1 of [3]

-  $\lceil N_{RB}^{DL} / P \rceil$  bits provide the resource allocation

- For resource allocation type 1 as defined in section 7.1.6.2 of [3]

-  $\lceil \log_2(P) \rceil$  bits of this field are used as a header specific to this resource allocation type to indicate the selected resource blocks subset

- 1 bit indicates a shift of the resource allocation span

-  $\left( \lceil N_{RB}^{DL} / P \rceil - \lceil \log_2(P) \rceil - 1 \right)$  bits provide the resource allocation

where the value of  $P$  depends on the number of DL resource blocks as indicated in section [7.1.6.1] of [3]

- TPC command for PUCCH – 2 bits as defined in section 5.1.2.1 of [3]
- Downlink Assignment Index (this field is present in TDD for all the uplink –downlink configurations and only applies to TDD operation with uplink –downlink configuration 1-6. This field is not present in FDD) – 2 bits
- HARQ process number - 3 bits (FDD), 4 bits (TDD)
- Antenna port(s), scrambling identity and number of layers – 3 bits as specified in Table 5.3.3.1.5C-1 where  $n_{SCID}$  is the scrambling identity for antenna ports 7 and 8 defined in section 6.10.3.1 of [2]
- SRS request – [0-1] bit. This field can only be present for TDD and if present is defined in section 8.2 of [3]

In addition, for transport block 1:

- Modulation and coding scheme – 5 bits as defined in section 7.1.7 of [3]
- New data indicator – 1 bit
- Redundancy version – 2 bits

In addition, for transport block 2:

- Modulation and coding scheme – 5 bits as defined in section 7.1.7 of [3]
- New data indicator – 1 bit
- Redundancy version – 2 bits

If both transport blocks are enabled; transport block 1 is mapped to codeword 0; and transport block 2 is mapped to codeword 1.

In case one of the transport blocks is disabled; the transport block to codeword mapping is specified according to Table 5.3.3.1.5-2. For the single enabled codeword, Value = 4, 5, 6 in Table 5.3.3.1.5C-1 are only supported for retransmission of the corresponding transport block if that transport block has previously been transmitted using two, three or four layers, respectively.

If the number of information bits in format 2C belongs to one of the sizes in Table 5.3.3.1.2-1, one zero bit shall be appended to format 2C.

**Table 5.3.3.1.5C-1: Antenna port(s), scrambling identity and number of layers indication**

One Codeword: Codeword 0 enabled, Codeword 1 disabled		Two Codewords: Codeword 0 enabled, Codeword 1 enabled	
Value	Message	Value	Message
0	1 layer, port 7, $n_{SCID}=0$	0	2 layers, ports 7-8, $n_{SCID}=0$
1	1 layer, port 7, $n_{SCID}=1$	1	2 layers, ports 7-8, $n_{SCID}=1$
2	1 layer, port 8, $n_{SCID}=0$	2	3 layers, ports 7-9
3	1 layer, port 8, $n_{SCID}=1$	3	4 layers, ports 7-10
4	2 layers, ports 7-8	4	5 layers, ports 7-11
5	3 layers, ports 7-9	5	6 layers, ports 7-12
6	4 layers, ports 7-10	6	7 layers, ports 7-13
7	Reserved	7	8 layers, ports 7-14

### 5.3.3.1.6 Format 3

DCI format 3 is used for the transmission of TPC commands for PUCCH and PUSCH with 2-bit power adjustments.



The following information is transmitted by means of the DCI format 3:

- TPC command number 1, TPC command number 2, ..., TPC command number  $N$

where  $N = \left\lfloor \frac{L_{\text{format } 0}}{2} \right\rfloor$ , and where  $L_{\text{format } 0}$  is equal to the payload size of format 0 before CRC attachment when format 0 is mapped onto the common search space, including any padding bits appended to format 0. The parameter *tpc-Index* provided by higher layers determines the index to the TPC command for a given UE.

If  $\left\lfloor \frac{L_{\text{format } 0}}{2} \right\rfloor < \frac{L_{\text{format } 0}}{2}$ , a bit of value zero shall be appended to format 3.

### 5.3.3.1.7 Format 3A

DCI format 3A is used for the transmission of TPC commands for PUCCH and PUSCH with single bit power adjustments.

The following information is transmitted by means of the DCI format 3A:

- TPC command number 1, TPC command number 2, ..., TPC command number  $M$

where  $M = L_{\text{format } 0}$ , and where  $L_{\text{format } 0}$  is equal to the payload size of format 0 before CRC attachment when format 0 is mapped onto the common search space, including any padding bits appended to format 0. The parameter *tpc-Index* provided by higher layers determines the index to the TPC command for a given UE.

### 5.3.3.1.8 Format 4

DCI format 4 is used for the scheduling of PUSCH in one UL cell with multi-antenna port transmission mode,

The following information is transmitted by means of the DCI format 4:

- Carrier indicator – 0 or 3 bits. The field is present according to the definitions in [3].

- Resource block assignment -  $\max \left( \left\lceil \log_2(N_{\text{RB}}^{\text{UL}}(N_{\text{RB}}^{\text{UL}} + 1)/2) \right\rceil, \left\lceil \log_2 \left( \left( \left\lceil \frac{N_{\text{RB}}^{\text{UL}}}{4} + 1 \right\rceil \right) \right) \right\rceil \right)$  bits, where  $P$  is the UL RBG size as defined in section 8.1.2 of [3]

- For resource allocation type 0:

- The  $\left\lceil \log_2(N_{\text{RB}}^{\text{UL}}(N_{\text{RB}}^{\text{UL}} + 1)/2) \right\rceil$  LSBs provide the resource allocation in the UL subframe as defined in section 8.1.1 of [3]

- For resource allocation type 1:

- The  $\left\lceil \log_2 \left( \left( \left\lceil \frac{N_{\text{RB}}^{\text{UL}}}{4} + 1 \right\rceil \right) \right) \right\rceil$  LSBs provide the resource allocation in the UL subframe as defined in section 8.1.2 of [3]

- TPC command for scheduled PUSCH – 2 bits as defined in section 5.1.1.1 of [3]

- Cyclic shift for DM RS and OCC index – 3 bits as defined in section 5.5.2.1.1 of [2]

- UL index – 2 bits as defined in sections 5.1.1.1, 7.2.1, 8 and 8.4 of [3] (this field is present only for TDD operation with uplink-downlink configuration 0)

- Downlink Assignment Index (DAI) – 2 bits as defined in section 7.3 of [3] (this field is present only for TDD operation with uplink-downlink configurations 1-6)
- CSI request – 1 or 2 bits as defined in section 7.2.1 of [3]. The 2-bit field applies to UEs that are configured with more than one DL cell; otherwise the 1-bit field applies
- SRS request – 2 bits as defined in section 8.2 of [3]
- Resource allocation type – 1 bit as defined in section 8.1 of [3]

In addition, for transport block 1:

- Modulation and coding scheme and redundancy version – 5 bits as defined in section 8.6 of [3]
- New data indicator – 1 bit

In addition, for transport block 2:

- Modulation and coding scheme and redundancy version – 5 bits as defined in section 8.6 of [3]
- New data indicator – 1 bit

Precoding information and number of layers: number of bits as specified in Table 5.3.3.1.8-1. Bit field as shown in Table 5.3.3.1.8-2 and Table 5.3.3.1.8-3. Note that TPMI for 2 antenna ports indicates which codebook index is to be used in Table 5.3.3A.2-1 of [2], and TPMI for 4 antenna ports indicates which codebook index is to be used in Table 5.3.3A.2-2, Table 5.3.3A.2-3, Table 5.3.3A.2-4 and Table 5.3.3A.2-5 of [2]. If both transport blocks are enabled, transport block 1 is mapped to codeword 0; and transport block 2 is mapped to codeword 1. In case one of the transport blocks is disabled, the transport block to codeword mapping is specified according to Table 5.3.3.1.5-2. For a single enabled codeword, indices 24 to 39 in Table 5.3.3.1.8-3 are only supported for retransmission of the corresponding transport block if that transport block has previously been transmitted using two layers.

**Table 5.3.3.1.8-1: Number of bits for precoding information.**

Number of antenna ports at UE	Number of bits for precoding information
2	3
4	6

**Table 5.3.3.1.8-2: Content of precoding information field for 2 antenna ports**

One codeword: Codeword 0 enabled Codeword 1 disabled		Two codewords: Codeword 0 enabled Codeword 1 enabled	
Bit field mapped to index	Message	Bit field mapped to index	Message
0	1 layer: TPMI=0	0	2 layers: TPMI=0
1	1 layer: TPMI=1	1-7	reserved
2	1 layer: TPMI=2		
...	...		
5	1 layer: TPMI=5		
6-7	reserved		

**Table 5.3.3.1.8-3: Content of precoding information field for 4 antenna ports**

One codeword: Codeword 0 enabled Codeword 1 disabled		Two codewords: Codeword 0 enabled Codeword 1 enabled	
Bit field mapped to index	Message	Bit field mapped to index	Message
0	1 layer: TPMI=0	0	2 layers: TPMI=0
1	1 layer: TPMI=1	1	2 layers: TPMI=1
...	...	...	...
23	1 layer: TPMI=23	15	2 layers: TPMI=15
24	2 layers: TPMI=0	16	3 layers: TPMI=0
25	2 layers: TPMI=1	17	3 layers: TPMI=1
...	...	...	...
39	2 layers: TPMI=15	27	3 layers: TPMI=11
40-63	reserved	28	4 layers: TPMI=0
		29 - 63	Reserved

If the number of information bits in format 4 is equal to the payload size for DCI format 1, 2, 2A, 2B or 2C associated with the configured DL transmission mode in the same serving cell, one zero bit shall be appended to format 4.

**5.3.3.2 CRC attachment**

Error detection is provided on DCI transmissions through a Cyclic Redundancy Check (CRC).

The entire PDCCH payload is used to calculate the CRC parity bits. Denote the bits of the PDCCH payload by  $a_0, a_1, a_2, a_3, \dots, a_{A-1}$ , and the parity bits by  $p_0, p_1, p_2, p_3, \dots, p_{L-1}$ .  $A$  is the PDCCH payload size and  $L$  is the number of parity bits.

The parity bits are computed and attached according to section 5.1.1 setting  $L$  to 16 bits, resulting in the sequence  $b_0, b_1, b_2, b_3, \dots, b_{B-1}$ , where  $B = A + L$ .

In the case where UE transmit antenna selection is not configured or applicable, after attachment, the CRC parity bits are scrambled with the corresponding RNTI  $x_{rnti,0}, x_{rnti,1}, \dots, x_{rnti,15}$ , where  $x_{rnti,0}$  corresponds to the MSB of the RNTI, to form the sequence of bits  $c_0, c_1, c_2, c_3, \dots, c_{B-1}$ . The relation between  $c_k$  and  $b_k$  is:

$$c_k = b_k \quad \text{for } k = 0, 1, 2, \dots, A-1$$

$$c_k = (b_k + x_{rnti,k-A}) \bmod 2 \quad \text{for } k = A, A+1, A+2, \dots, A+15.$$

In the case where UE transmit antenna selection is configured and applicable, after attachment, the CRC parity bits of PDCCH with DCI format 0 are scrambled with the antenna selection mask  $x_{AS,0}, x_{AS,1}, \dots, x_{AS,15}$  as indicated in Table 5.3.3.2-1 and the corresponding RNTI  $x_{rnti,0}, x_{rnti,1}, \dots, x_{rnti,15}$  to form the sequence of bits  $c_0, c_1, c_2, c_3, \dots, c_{B-1}$ . The relation between  $c_k$  and  $b_k$  is:

$$c_k = b_k \quad \text{for } k = 0, 1, 2, \dots, A-1$$

$$c_k = (b_k + x_{rnti,k-A} + x_{AS,k-A}) \bmod 2 \quad \text{for } k = A, A+1, A+2, \dots, A+15.$$

**Table 5.3.3.2-1: UE transmit antenna selection mask.**

UE transmit antenna selection	Antenna selection mask $\langle x_{AS,0}, x_{AS,1}, \dots, x_{AS,15} \rangle$
UE port 0	$\langle 0, 0, 0, 0, 0, 0, 0, 0, 0, 0, 0, 0, 0, 0, 0, 0 \rangle$
UE port 1	$\langle 0, 0, 0, 0, 0, 0, 0, 0, 0, 0, 0, 0, 0, 0, 0, 1 \rangle$

### 5.3.3.3 Channel coding

Information bits are delivered to the channel coding block. They are denoted by  $c_0, c_1, c_2, c_3, \dots, c_{K-1}$ , where  $K$  is the number of bits, and they are tail biting convolutionally encoded according to section 5.1.3.1.

After encoding the bits are denoted by  $d_0^{(i)}, d_1^{(i)}, d_2^{(i)}, d_3^{(i)}, \dots, d_{D-1}^{(i)}$ , with  $i = 0, 1, \text{ and } 2$ , and where  $D$  is the number of bits on the  $i$ -th coded stream, i.e.,  $D = K$ .

### 5.3.3.4 Rate matching

A tail biting convolutionally coded block is delivered to the rate matching block. This block of coded bits is denoted by  $d_0^{(i)}, d_1^{(i)}, d_2^{(i)}, d_3^{(i)}, \dots, d_{D-1}^{(i)}$ , with  $i = 0, 1, \text{ and } 2$ , and where  $i$  is the coded stream index and  $D$  is the number of bits in each coded stream. This coded block is rate matched according to section 5.1.4.2.

After rate matching, the bits are denoted by  $e_0, e_1, e_2, e_3, \dots, e_{E-1}$ , where  $E$  is the number of rate matched bits.

## 5.3.4 Control format indicator

Data arrives each subframe to the coding unit in the form of an indicator for the time span, in units of OFDM symbols, of the DCI in that subframe of the corresponding DL cell. The CFI takes values CFI = 1, 2 or 3. For system bandwidths  $N_{RB}^{DL} > 10$ , the span of the DCI in units of OFDM symbols, 1, 2 or 3, is given by the CFI. For system bandwidths  $N_{RB}^{DL} \leq 10$ , the span of the DCI in units of OFDM symbols, 2, 3 or 4, is given by CFI+1.

The coding flow is shown in Figure 5.3.4-1.

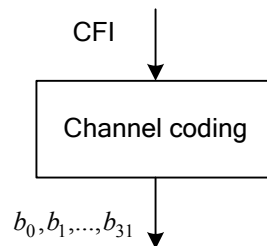

Figure 5.3.4-1 Coding for CFI.

### 5.3.4.1 Channel coding

The control format indicator is coded according to Table 5.3.4-1.

Table 5.3.4-1: CFI code words.

CFI	CFI code word < $b_0, b_1, \dots, b_{31}$ >
1	<0,1,1,0,1,1,0,1,1,0,1,1,0,1,1,0,1,1,0,1,1,0,1,1,0,1,1,0,1,1,0,1>
2	<1,0,1,1,0,1,1,0,1,1,0,1,1,0,1,1,0,1,1,0,1,1,0,1,1,0,1,1,0,1,1,0>
3	<1,1,0,1,1,0,1,1,0,1,1,0,1,1,0,1,1,0,1,1,0,1,1,0,1,1,0,1,1,0,1,1>
4 (Reserved)	<0,0>

### 5.3.5 HARQ indicator (HI)

Data arrives to the coding unit in the form of indicators for HARQ acknowledgement for one transport block.

The coding flow is shown in Figure 5.3.5-1.

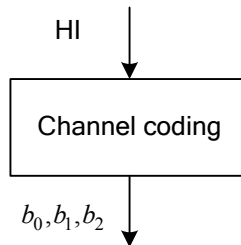

**Figure 5.3.5-1 Coding for HI.**

#### 5.3.5.1 Channel coding

The HI is coded according to Table 5.3.5-1, where for a positive acknowledgement HI = 1 and for a negative acknowledgement HI = 0.

**Table 5.3.5-1: HI code words.**

<b>HI</b>	<b>HI code word &lt; b<sub>0</sub>, b<sub>1</sub>, b<sub>2</sub> &gt;</b>
0	< 0,0,0 >
1	< 1,1,1 >

## Annex A (informative): Change history

Change history							
Date	TSG #	TSG Doc.	CR	Rev	Subject/Comment	Old	New
2006-09					Skeleton		0.0.0
2006-10					Updated skeleton	0.0.0	0.0.1
2006-10					Endorsed skeleton	0.0.1	0.1.0
2006-11					Added TC. Added Broadcast, Paging and MBMS transport channels in Table 4.2-1.	0.1.0	0.1.1
2006-11					Endorsed v 0.2.0	0.1.1	0.2.0
2006-12					Added CC. Added type of coding for each transport channel or control information.	0.2.0	0.2.1
2007-01					Editor's version	0.2.1	0.2.2
2007-01					Endorsed v 0.3.0	0.2.2	0.3.0
2007-02					Added QPP turbo Interleaver description.	0.3.0	0.3.1
2007-02					Editor's version	0.3.1	0.3.2
2007-02					Endorsed v 0.4.0	0.3.2	0.4.0
2007-02					Added CRC details for PDSCH, PDCCH and PUSCH. Added QPP turbo-interleaver parameters. Set Z to 6144. Added details on code block segmentation.	0.4.0	0.4.1
2007-02					Editor's version	0.4.1	0.4.2
2007-03	RAN#35	RP-070170			For information at RAN#35	0.4.2	1.0.0
2007-03					Editor's version	1.0.0	1.0.1
2007-03					Editor's version	1.0.1	1.1.0
2007-05					Editor's version	1.1.0	1.1.1
2007-05					Editor's version	1.1.1	1.1.2
2007-05					Editor's version	1.1.2	1.2.0
2007-06					Added circular buffer rate matching for PDSCH and PUSCH. Miscellaneous changes.	1.2.0	1.2.1
2007-06					Editor's version	1.2.1	1.2.2
2007-07					Editor's version	1.2.2	1.2.3
2007-07					Endorsed by email following decision taken at RAN1#49b	1.2.3	1.3.0
2007-08					Editor's version including decision from RAN1#49bis.	1.3.0	1.3.1
2007-08					Editor's version	1.3.1	1.3.2
2007-08					Editor's version	1.3.2	1.4.0
2007-09					Editor's version with decisions from RAN1#50	1.4.0	1.4.1
2007-09					Editor's version	1.4.1	1.4.2
10/09/07	RAN#37	RP-070730	-	-	For approval at RAN#37	1.4.2	2.0.0
12/09/07	RAN_37	RP-070730	-	-	Approved version	2.0.0	8.0.0
28/11/07	RAN_38	RP-070949	0001	-	Update of 36.212	8.0.0	8.1.0
05/03/08	RAN_39	RP-080145	0002	-	Update to 36.212 incorporating decisions from RAN1#51bis and RAN1#52	8.1.0	8.2.0
28/05/08	RAN_40	RP-080433	0003	-	Joint coding of CQI and ACK on PUCCH	8.2.0	8.3.0
28/05/08	RAN_40	RP-080433	0004	1	ACK insertion into PUSCH	8.2.0	8.3.0
28/05/08	RAN_40	RP-080433	0005	1	Introduction of format 1C	8.2.0	8.3.0
28/05/08	RAN_40	RP-080433	0006	1	Miscellaneous fixes to 36.212	8.2.0	8.3.0
28/05/08	RAN_40	RP-080433	0008	1	On multiplexing scheme for indicators	8.2.0	8.3.0
28/05/08	RAN_40	RP-080433	0009	1	On the soft buffer split of MIMO and TDD	8.2.0	8.3.0
28/05/08	RAN_40	RP-080433	0010	-	Resource assignment field for distributed VRB	8.2.0	8.3.0
28/05/08	RAN_40	RP-080433	0011	-	Clarifying the use of the different DCI formats	8.2.0	8.3.0
28/05/08	RAN_40	RP-080433	0012	1	Clarifying the value of $N_L$	8.2.0	8.3.0
28/05/08	RAN_40	RP-080433	0013	-	Payload size for DCI formats 3 and 3A	8.2.0	8.3.0
28/05/08	RAN_40	RP-080433	0014	-	Coding of ACK on PUSCH	8.2.0	8.3.0
28/05/08	RAN_40	RP-080433	0015	1	Coding of RI on PUSCH and mapping	8.2.0	8.3.0
28/05/08	RAN_40	RP-080433	0016	-	CRC for control information on PUSCH	8.2.0	8.3.0
28/05/08	RAN_40	RP-080433	0017	-	Introduction of Downlink Assignment Index	8.2.0	8.3.0
28/05/08	RAN_40	RP-080433	0018	-	Coding of CQI/PMI on PUSCH coming from PUCCH	8.2.0	8.3.0
28/05/08	RAN_40	RP-080433	0019	-	Simultaneous transmission of aperiodic CQI and UL control	8.2.0	8.3.0
28/05/08	RAN_40	RP-080433	0020	-	Encoding of antenna indicator on DCI format 0	8.2.0	8.3.0
28/05/08	RAN_40	RP-080433	0021	-	PDCCH coverage in narrow bandwidths	8.2.0	8.3.0
28/05/08	RAN_40	RP-080433	0022	-	Closed-loop and open-loop spatial multiplexing	8.2.0	8.3.0
28/05/08	RAN_40	RP-080457	0023	-	Formula for linkage between PUSCH MCS and amount of resources used for control	8.2.0	8.3.0
09/09/08	RAN_41	RP-080669	0026	-	Correction to PUSCH Channel Interleaver	8.3.0	8.4.0
09/09/08	RAN_41	RP-080669	0028	-	Correction of mapping of ACK/NAK to binary bit values	8.3.0	8.4.0
09/09/08	RAN_41	RP-080669	0029	-	Correction to bit collection, selection and transmission	8.3.0	8.4.0

Change history							
Date	TSG #	TSG Doc.	CR	Rev	Subject/Comment	Old	New
09/09/08	RAN_41	RP-080669	0030	-	Padding one bit to DCI format 1 when format 1 and format 0/1A have the same size	8.3.0	8.4.0
09/09/08	RAN_41	RP-080669	0031	-	Modification of M <sub>limit</sub>	8.3.0	8.4.0
09/09/08	RAN_41	RP-080669	0032	-	Definition of Formats 2 and 2A	8.3.0	8.4.0
09/09/08	RAN_41	RP-080669	0033	2	Corrections to DCI formats	8.3.0	8.4.0
09/09/08	RAN_41	RP-080669	0035	1	Format 1B confirmation flag	8.3.0	8.4.0
09/09/08	RAN_41	RP-080669	0036	-	Corrections to Rank information scrambling in Uplink Shared Channel	8.3.0	8.4.0
09/09/08	RAN_41	RP-080669	0037	2	Clarification of TPC commands signaled in DCI formats 3/3A	8.3.0	8.4.0
09/09/08	RAN_41	RP-080669	0038	-	Clarification on UE transmit antenna selection mask	8.3.0	8.4.0
09/09/08	RAN_41	RP-080669	0039	1	Linking of control resources in PUSCH to data MCS	8.3.0	8.4.0
09/09/08	RAN_41	RP-080669	0041	-	Definition of Bit Mapping for DCI signalling	8.3.0	8.4.0
09/09/08	RAN_41	RP-080669	0042	1	Clarification on resource allocation in DCI format 1/2/2A	8.3.0	8.4.0
09/09/08	RAN_41	RP-080669	0043	-	DCI Format 1A changes needed for scheduling Broadcast Control	8.3.0	8.4.0
09/09/08	RAN_41	RP-080669	0044	-	DCI format 1C	8.3.0	8.4.0
09/09/08	RAN_41	RP-080669	0045	-	Miscellaneous corrections	8.3.0	8.4.0
11/09/08	RAN_41	RP-080736	0046	1	Correction on downlink multi-user MIMO	8.3.0	8.4.0
09/09/08	RAN_41	RP-080669	0047	-	Corrections to DL DCI Formats In case of Ambiguous Payload Sizes	8.3.0	8.4.0
09/09/08	RAN_41	RP-080669	0048	-	CR for RE provisioning for the control information in case of CQI-only transmission on PUSCH	8.3.0	8.4.0
09/09/08	RAN_41	RP-080669	0091	2	Coding and multiplexing of multiple ACK/NACK in PUSCH	8.3.0	8.4.0
03/12/08	RAN_42	RP-080983	0050	2	Clarification of input bits corresponding to 2-bit HARQ-ACK and 2-bit RI	8.4.0	8.5.0
03/12/08	RAN_42	RP-080983	0053	-	Editorial corrections to 36.212	8.4.0	8.5.0
03/12/08	RAN_42	RP-080983	0055	-	Miscellaneous Corrections	8.4.0	8.5.0
03/12/08	RAN_42	RP-080983	0057	-	Clarification of mapping of information bits	8.4.0	8.5.0
03/12/08	RAN_42	RP-080983	0058	-	Completion of 36.212 CR47 (R1-083421) for "new" DCI Formats	8.4.0	8.5.0
03/12/08	RAN_42	RP-080983	0059	-	Change for determining DCI format 1A TBS table column indicator for broadcast control	8.4.0	8.5.0
03/12/08	RAN_42	RP-080983	0061	2	Defining DCI format 1A for downlink data arrival	8.4.0	8.5.0
03/12/08	RAN_42	RP-080983	0063	1	ACK/NACK transmission on PUSCH for LTE TDD	8.4.0	8.5.0
03/12/08	RAN_42	RP-080983	0065	-	Correction in 36.212 related to TDD downlink HARQ processes	8.4.0	8.5.0
03/12/08	RAN_42	RP-080983	0067	1	Correction of control MCS offset and SRS symbol puncturing	8.4.0	8.5.0
03/12/08	RAN_42	RP-080983	0068	1	DCI format 2/2A	8.4.0	8.5.0
03/12/08	RAN_42	RP-080983	0069	-	Correction to zero padding in DCI format 1	8.4.0	8.5.0
03/12/08	RAN_42	RP-080983	0071	-	Clarification of RI bit field mapping for PUCCH	8.4.0	8.5.0
03/12/08	RAN_42	RP-080983	0072	-	Clarifying RNTI bit mapping for PDCCH CRC scrambling	8.4.0	8.5.0
03/12/08	RAN_42	RP-080983	0073	-	Clarification on BCH transport block size	8.4.0	8.5.0
03/12/08	RAN_42	RP-080983	0076	-	Clarification on the number of PUCCH-based CQI/PMI bits when reported on PUSCH	8.4.0	8.5.0
04/03/09	RAN_43	RP-090235	77	1	Corrections to Transmitted Rank Indication	8.5.0	8.6.0
04/03/09	RAN_43	RP-090235	79	1	Correction to the bundled ACK/NACK and DAI transmission	8.5.0	8.6.0
04/03/09	RAN_43	RP-090235	80	2	Corrections to transmission modes	8.5.0	8.6.0
04/03/09	RAN_43	RP-090235	81	1	Correction on ACKNACK transmission on PUSCH for LTE TDD	8.5.0	8.6.0
04/03/09	RAN_43	RP-090235	82	2	Corrections to CQI and RI fields description	8.5.0	8.6.0
04/03/09	RAN_43	RP-090235	83	-	Clarifying DCI format 1A and DCI Format 1B	8.5.0	8.6.0
04/03/09	RAN_43	RP-090235	92	1	Clarification on channel coding for UCI HARQ-ACK	8.5.0	8.6.0
27/05/09	RAN_44	RP-090528	87	-	Clarify some parameters for determining control resources on PUSCH	8.6.0	8.7.0
01/12/09	RAN_46	RP-091168	89	-	Clarification on bitwidth of RI	8.7.0	8.8.0
01/12/09	RAN_46	RP-091168	94	-	Correction to Channel interleaver for PUSCH RE Mapping	8.7.0	8.8.0
01/12/09	RAN_46	RP-091177	88	1	Editorial corrections to 36.212	8.8.0	9.0.0
01/12/09	RAN_46	RP-091257	95	1	Introduction of enhanced dual layer transmission	8.8.0	9.0.0
16/03/10	RAN_47	RP-100210	96	1	MCCH change notification using DCI format 1C	9.0.0	9.1.0
16/03/10	RAN_47	RP-100211	97	-	Addition of missing reference to DCI format 2B + typo corrections	9.0.0	9.1.0
01/06/10	RAN_48	RP-100589	98	-	Correction to TBS determination for DCI format 1C	9.1.0	9.2.0
14/09/10	RAN_49	RP-100899	99	-	Clarify soft buffer size determination for MCH	9.2.0	9.3.0
07/12/10	RAN_50	RP-101320	100	-	Introduction of Rel-10 LTE-Advanced features in 36.212	9.3.0	10.0.0
15/03/11	RAN_51	RP-110254	101	-	Correction on UE behavior upon receiving DCI format 1B	10.0.0	10.1.0
15/03/11	RAN_51	RP-110256	102	-	Corrections to Rel-10 LTE-Advanced features in 36.212	10.0.0	10.1.0
01/06/11	RAN_52	RP-110819	103	3	Correction of DCI format 0 and 4 resource allocation	10.1.0	10.2.0
01/06/11	RAN_52	RP-110819	104	2	Correction to Multi-cluster flag in DCI format 0	10.1.0	10.2.0
01/06/11	RAN_52	RP-110819	107	2	Corrections on HARQ-ACK Channel Coding in the PUSCH	10.1.0	10.2.0
01/06/11	RAN_52	RP-110820	108	3	A clarification for DCI format payload size	10.1.0	10.2.0
01/06/11	RAN_52	RP-110819	110	1	Correction the search space and RNTI for CQI and SRS request flag	10.1.0	10.2.0
01/06/11	RAN_52	RP-110819	111	-	Resource dimensioning for CQI only PUSCH transmission	10.1.0	10.2.0
01/06/11	RAN_52	RP-110820	112	1	Correction on bit representations of transport block processing for UL-SCH	10.1.0	10.2.0

Change history							
Date	TSG #	TSG Doc.	CR	Rev	Subject/Comment	Old	New
01/06/11	RAN_52	RP-110818	113	-	Clarification on PMI indication in DCI format1B and format 2	10.1.0	10.2.0
01/06/11	RAN_52	RP-110820	114	1	Rate matching parameters for CA	10.1.0	10.2.0
01/06/11	RAN_52	RP-110819	116	-	HARQ-ACK on PUSCH for TDD with channel selection configured for 2 serving cells	10.1.0	10.2.0
01/06/11	RAN_52	RP-110823	117	-	Single codeword multiple layer transmission in uplink	10.1.0	10.2.0
15/09/11	RAN_53	RP-111228	119	1	Corrections on transport block processing for UL-SCH	10.2.0	10.3.0
15/09/11	RAN_53	RP-111230	120	2	On correction of channel coding of control information	10.2.0	10.3.0
15/09/11	RAN_53	RP-111230	122	1	Size adjustment of DCI format 0, 1A and 1	10.2.0	10.3.0
15/09/11	RAN_53	RP-111232	123	1	Corrections on Nsrs	10.2.0	10.3.0
15/09/11	RAN_53	RP-111232	124	2	Corrections on DCI format 1B/1D	10.2.0	10.3.0
15/09/11	RAN_53	RP-111228	125	-	Minor Correction on DCI Format 1 Description	10.2.0	10.3.0
15/09/11	RAN_53	RP-111226	127	-	Correction on ACK/NACK mapping	10.2.0	10.3.0
15/09/11	RAN_53	RP-111231	128	-	Corrections on channel coding of control information and DCI Format 4.	10.2.0	10.3.0
15/09/11	RAN_53	RP-111229	129	-	Clarification and correction to configuration signalling condition for channel quality information formats	10.2.0	10.3.0
05/12/11	RAN_54	RP-111667	130	1	Corrections on codebook index indication in DCI format 4	10.3.0	10.4.0
05/12/11	RAN_54	RP-111666	131	-	HARQ-ACK on UCI-only PUSCH without UL-SCH data	10.3.0	10.4.0
28/02/12	RAN_55	RP-120283	132	2	Corrections on payload size adjustment for DCI format 1A and 1	10.4.0	10.5.0
28/02/12	RAN_55	RP-120283	133	1	Correction of two HARQ-ACK feedback on PUSCH	10.4.0	10.5.0
28/02/12	RAN_55	RP-120285	134	1	Miscellaneous corrections	10.4.0	10.5.0
13/06/12	RAN_56	RP-120739	136	-	Correction to Data and control multiplexing	10.5.0	10.6.0
13/06/12	RAN_56	RP-120737	138	-	Correction to CSI request field size in DCI format 0 and DCI format 4	10.5.0	10.6.0
04/12/12	RAN_58	RP-121839	140	-	Correction on bit sequence for channel coding of RI on PUCCH	10.6.0	10.7.0
04/12/12	RAN_58	RP-121839	142	-	Correction to the parameter ue-Category-v10xy	10.6.0	10.7.0
11/06/13	RAN_60	RP-130751	146	2	Correction on the RI bit width	10.7.0	10.8.0
11/06/13	RAN_60	RP-130749	152	-	Correction to bit padding of DCI format 1A for secondary cell without uplink component carrier	10.7.0	10.8.0
14/09/15	RAN_69	RP-151466	172	1	Introducing 4-layer MIMO transmission in TM3 and TM4	10.8.0	10.9.0