



**ARIB STD-T104-36.360 V13.0.0**

**Evolved Universal Terrestrial  
Radio Access (E-UTRA); LTE-  
WLAN Aggregation Adaptation  
Protocol (LWAAP) specification**

**(Release 13)**

---

Refer to "Industrial Property Rights (IPR)" in the preface of ARIB STD-T104 for Related Industrial Property Rights. Refer to "Notice" in the preface of ARIB STD-T104 for Copyrights.

# 3GPP TS 36.360 V13.0.0 (2016-03)

---

*Technical Specification*

## **3rd Generation Partnership Project; Technical Specification Group Radio Access Network; Evolved Universal Terrestrial Radio Access (E-UTRA); LTE-WLAN Aggregation Adaptation Protocol (LWAAP) specification (Release 13)**



Keywords

---

LTE, radio

**3GPP**

Postal address

---

3GPP support office address

---

650 Route des Lucioles - Sophia Antipolis  
Valbonne - FRANCE  
Tel.: +33 4 92 94 42 00 Fax: +33 4 93 65 47 16

Internet

---

<http://www.3gpp.org>

---

**Copyright Notification**

---

No part may be reproduced except as authorized by written permission.  
The copyright and the foregoing restriction extend to reproduction in all media.

© 2016, 3GPP Organizational Partners (ARIB, ATIS, CCSA, ETSI, TSDSI, TTA, TTC).  
All rights reserved.

UMTS™ is a Trade Mark of ETSI registered for the benefit of its members  
3GPP™ is a Trade Mark of ETSI registered for the benefit of its Members and of the 3GPP Organizational Partners  
LTE™ is a Trade Mark of ETSI registered for the benefit of its Members and of the 3GPP Organizational Partners  
GSM® and the GSM logo are registered and owned by the GSM Association

---

# Contents

Foreword.....	4
1 Scope.....	5
2 References.....	5
3 Definitions, symbols and abbreviations .....	5
3.1 Definitions .....	5
3.2 Abbreviations.....	5
4 General .....	6
4.1 Introduction.....	6
4.2 LWAAP architecture .....	6
4.2.1 LWAAP entities .....	6
4.3 Services.....	7
4.3.1 Services provided to upper layers .....	7
4.3.2 Services expected from lower layers.....	7
4.4 Functions .....	7
5 Procedures .....	7
5.1 Data transfer procedures .....	7
5.1.1 DL data transfer procedures .....	7
5.2 Handling of unknown, unforeseen and erroneous protocol data.....	7
6 Protocol data units, formats and parameters .....	8
6.1 Protocol data units .....	8
6.1.1 General .....	8
6.1.2 LWAAP data PDU.....	8
6.2 Formats and parameters .....	8
6.2.1 LWAAP header.....	8
<b>Annex A (informative): Change history .....</b>	<b>9</b>

---

## Foreword

This Technical Specification has been produced by the 3<sup>rd</sup> Generation Partnership Project (3GPP).

The contents of the present document are subject to continuing work within the TSG and may change following formal TSG approval. Should the TSG modify the contents of the present document, it will be re-released by the TSG with an identifying change of release date and an increase in version number as follows:

Version x.y.z

where:

- x the first digit:
  - 1 presented to TSG for information;
  - 2 presented to TSG for approval;
  - 3 or greater indicates TSG approved document under change control.
- y the second digit is incremented for all changes of substance, i.e. technical enhancements, corrections, updates, etc.
- z the third digit is incremented when editorial only changes have been incorporated in the document.

---

# 1 Scope

The present document specifies the E-UTRA LTE-WLAN Aggregation Adaptation Protocol (LWAAP).

---

## 2 References

The following documents contain provisions which, through reference in this text, constitute provisions of the present document.

- References are either specific (identified by date of publication, edition number, version number, etc.) or non-specific.
- For a specific reference, subsequent revisions do not apply.
- For a non-specific reference, the latest version applies. In the case of a reference to a 3GPP document (including a GSM document), a non-specific reference implicitly refers to the latest version of that document *in the same Release as the present document*.

- [1] 3GPP TR 21.905: "Vocabulary for 3GPP Specifications".
  - [2] 3GPP TS 36.300: "E-UTRA and E-UTRAN Overall Description; Stage 2".
  - [3] 3GPP TS 36.323: "E-UTRA PDCP specification".
  - [4] 3GPP TS 36.331: "E-UTRA RRC Protocol specification".
- 

## 3 Definitions, symbols and abbreviations

### 3.1 Definitions

For the purposes of the present document, the terms and definitions given in TR 21.905 [1] and the following apply. A term defined in the present document takes precedence over the definition of the same term, if any, in TR 21.905 [1].

**LWA bearer:** a bearer used in LTE-WLAN Aggregation, as defined in TS 36.300 [2].

### 3.2 Abbreviations

For the purposes of the present document, the following abbreviations apply:

DL	DownLink
DRB	Data Radio Bearer
eNB	E-UTRAN Node B
E-UTRA	Evolved UMTS Terrestrial Radio Access
E-UTRAN	Evolved UMTS Terrestrial Radio Access Network
LWAAP	LTE-WLAN Aggregation Adaptation Protocol
PDCP	Packet Data Convergence Protocol
PDU	Protocol Data Unit
RRC	Radio Resource Control
SAP	Service Access Point
SDU	Service Data Unit
UE	User Equipment

# 4 General

## 4.1 Introduction

The objective is to describe the LWAAP architecture and the LWAAP entities from a functional point of view.

## 4.2 LWAAP architecture

### 4.2.1 LWAAP entities

The description in this sub clause is a model and does not specify or restrict implementations.

RRC is generally in control of the LWAAP configuration.

Functions of the LWAAP sublayer are performed by LWAAP entities. For an LWAAP entity configured at the eNB, there is a peer LWAAP entity configured at the UE and vice versa. For all LWA bearers, there is one LWAAP entity in the eNB and one LWAAP entity in the UE.

An LWAAP entity receives/delivers LWAAP SDUs from/to upper layers (i.e. PDCP) and sends/receives LWAAP PDUs to/from its peer LWAAP entity via WLAN:

- At the eNB, when an LWAAP entity receives an LWAAP SDU from upper layers, it constructs the corresponding LWAAP PDU and delivers it to lower layers;
- At the UE, when an LWAAP entity receives an LWAAP PDU from lower layers, it reassembles the corresponding LWAAP SDU and delivers it to upper layers.

Figure 4.2.1-1 illustrates the overview model of the LWAAP sublayer.

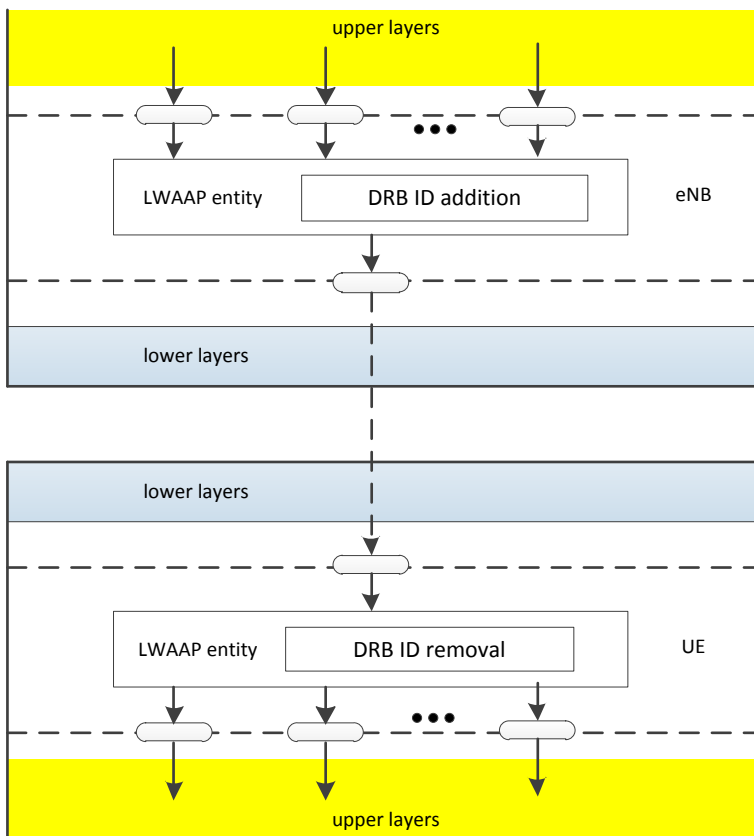

Figure 4.2.1-1: Overview model of the LWAAP sublayer

An LWAAP entity delivers/receives the following LWAAP PDU to/from a lower layer entity:

- LWAAP data PDU.

## 4.3 Services

### 4.3.1 Services provided to upper layers

The following services are provided by LWAAP to upper layers (i.e. PDCP):

- transfer of user plane data;

### 4.3.2 Services expected from lower layers

The following services are expected by LWAAP from lower layers:

- transfer of user plane data;

## 4.4 Functions

The following functions are supported by the LWAAP sublayer:

- transfer of user plane data;
- identification of the LWA bearer to which the LWAAP SDU belongs.

---

# 5 Procedures

## 5.1 Data transfer procedures

### 5.1.1 DL data transfer procedures

When receiving an LWAAP data PDU from lower layers, the LWAAP entity in the UE shall:

- identify the upper layer entity to which the LWAAP SDU is destined based on the DRB ID included in the LWAAP header;
- reassemble the LWAAP SDU from the LWAAP data PDU by removing the LWAAP header from the LWAAP data PDU;
- deliver the reassembled LWAAP SDU to the upper layer entity identified by the DRB ID.

## 5.2 Handling of unknown, unforeseen and erroneous protocol data

When an LWAAP entity receives an LWAAP PDU that contains reserved or invalid values, the LWAAP entity shall:

- discard the received PDU.



## 6 Protocol data units, formats and parameters

### 6.1 Protocol data units

#### 6.1.1 General

An LWAAP PDU is a bit string that is byte aligned (i.e. multiple of 8 bits) in length. In the figures in subclause 6.1, bit strings are represented by tables in which the most significant bit is the leftmost bit of the first line of the table, the least significant bit is the rightmost bit on the last line of the table, and more generally the bit string is to be read from left to right and then in the reading order of the lines. The bit order of each parameter field within an LWAAP PDU is represented with the first and most significant bit in the leftmost bit and the last and least significant bit in the rightmost bit.

An LWAAP SDU is a bit string that is byte aligned (i.e. multiple of 8 bits) in length. An LWAAP SDU is included into an LWAAP PDU from the first bit onward.

The LWAAP entity shall ignore the value of Reserved bits in downlink LWAAP PDUs.

Only one type of LWAAP PDU is defined, i.e. LWAAP data PDU.

#### 6.1.2 LWAAP data PDU

An LWAAP PDU consists of an LWAAP header and a Data field, as described in Figure 6.1.2-1.

An LWAAP header is one byte, and consists of the four header fields R/R/R/DRBID.

A Data field is of variable size, and consists of an LWAAP SDU.

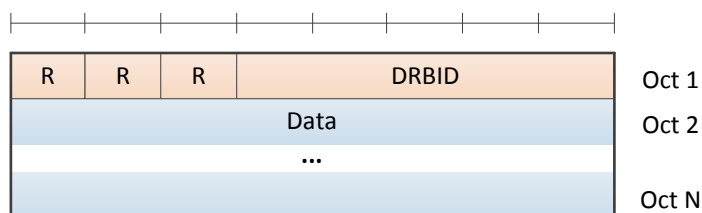

Figure 6.1.2-1: LWAAP data PDU

## 6.2 Formats and parameters

### 6.2.1 LWAAP header

The LWAAP header consists of the following fields:

- R: Reserved bit, set to "0". The R field size is 1 bit;
- DRBID: The Data Radio Bearer ID field indicates the RRC configured DRB identity to which the corresponding LWAAP SDU belongs. The DRBID field size is 5 bits.

## Annex A (informative): Change history

Change history							
Date	TSG #	TSG Doc.	CR	Rev	Subject/Comment	Old	New
2016-02	RAN2#93	R2-161087	-	-	draft TS 36.360 v0.0.0 on LTE-WLAN Aggregation Adaptation Protocol (LWAAP) specification after e-mail discussion "[92#42][LTE/WLAN] New specification (LG)"	-	0.0.0
2016-02	RAN2#93	R2-161787	-	-	draft TS 36.360 v0.0.1 on LTE-WLAN Aggregation Adaptation Protocol (LWAAP) specification	0.0.0	0.0.1
2016-02	RAN2#93	R2-161986	-	-	draft TS 36.360 v0.0.2 on LTE-WLAN Aggregation Adaptation Protocol (LWAAP) specification	0.0.1	0.0.2
2016-02	RAN2#93	R2-162023	-	-	draft TS 36.360 v0.1.0 on LTE-WLAN Aggregation Adaptation Protocol (LWAAP) specification	0.0.2	0.1.0
2016-02	RAN2#93	R2-162024	-	-	draft TS 36.360 v1.0.0 on LTE-WLAN Aggregation Adaptation Protocol (LWAAP) specification	0.1.0	1.0.0
2016-03	RP-71	RP-160496	-	-	Approved at TSG RAN#71 and put under Change Control	1.0.0	13.0.0