

3GPP TS 23.216 V10.6.0 (2013-06)

Technical Specification

**3rd Generation Partnership Project;
Technical Specification Group Services and System Aspects;
Single Radio Voice Call Continuity (SRVCC);
Stage 2
(Release 10)**



The present document has been developed within the 3rd Generation Partnership Project (3GPP™) and may be further elaborated for the purposes of 3GPP. The present document has not been subject to any approval process by the 3GPP Organizational Partners and shall not be implemented. This Specification is provided for future development work within 3GPP only. The Organizational Partners accept no liability for any use of this Specification. Specifications and reports for implementation of the 3GPP™ system should be obtained via the 3GPP Organizational Partners' Publications Offices.

Keywords

LTE, UMTS, GSM, Circuit mode, IP, multimedia,
IMS, voice

3GPP

Postal address

3GPP support office address

650 Route des Lucioles - Sophia Antipolis
Valbonne - FRANCE
Tel.: +33 4 92 94 42 00 Fax: +33 4 93 65 47 16
Intpp.org

Copyright Notification

No part may be reproduced except as authorized by written permission.
The copyright and the foregoing restriction extend to reproduction in all media.

© 2013, 3GPP Organizational Partners (ARIB, ATIS, CCSA, ETSI, TTA, TTC).
All rights reserved.

UMTS™ is a Trade Mark of ETSI registered for the benefit of its members
3GPP™ is a Trade Mark of ETSI registered for the benefit of its Members and of the 3GPP Organizational Partners
LTE™ is a Trade Mark of ETSI currently being registered for the benefit of its Members and of the 3GPP Organizational Partners
GSM® and the GSM logo are registered and owned by the GSM Association

Contents

Foreword	5
1 Scope	6
2 References	6
3 Definitions and abbreviations.....	7
3.1 Definitions	7
3.3 Abbreviations.....	8
4 High level Principles and Concepts	8
4.1 High level Principles	8
4.1.1 Architectural Principles for 3GPP2 1xCS SRVCC	8
4.1.2 Architectural Principles for 3GPP UTRAN/GERAN SRVCC	9
4.2 Concepts	9
4.2.1 E-UTRAN and 3GPP2 1xCS SRVCC	9
4.2.2 E-UTRAN and 3GPP UTRAN/GERAN SRVCC.....	10
4.2.3 UTRAN (HSPA) to 3GPP UTRAN/GERAN SRVCC	10
4.2.4 SRVCC for IMS emergency sessions	11
4.2.4.1 E-UTRAN/UTRAN (HSPA) to 3GPP UTRAN/GERAN	11
4.2.4.2 E-UTRAN to 3GPP2 1xCS	12
4.2.4.3 SRVCC in Limited Service Mode	13
4.2.4.3.1 E-UTRAN/UTRAN (HSPA) to 3GPP UTRAN/GERAN.....	13
4.2.4.3.2 E-UTRAN to 3GPP2 1xCS.....	13
5 Architecture model and reference points.....	14
5.1 General.....	14
5.2 Reference architecture	14
5.2.1 E-UTRAN and 3GPP2 1xCS SRVCC architecture.....	14
5.2.2 E-UTRAN and 3GPP UTRAN/GERAN SRVCC architecture.....	14
5.2.3 UTRAN (HSPA) and 3GPP UTRAN/GERAN SRVCC architecture	15
5.3 Functional Entities	16
5.3.1 3GPP2 1x CS SRVCC interworking solution function (1xCS IWS)	16
5.3.2 MSC Server enhanced for E-UTRAN/UTRAN (HSPA) and 3GPP UTRAN/GERAN SRVCC.....	16
5.3.3 MME	17
5.3.3.1 Interworking with 3GPP2 1xCS IWS.....	17
5.3.3.1.1 Interworking with 3GPP2 1xCS IWS	17
5.3.3.1.2 Selection of 3GPP2 1xCS IWS.....	17
5.3.3.2 Interworking with 3GPP MSC Server enhanced for SRVCC.....	17
5.3.3.2.1 Interworking with 3GPP MSC Server enhanced for SRVCC.....	17
5.3.3.2.2 PS bearer splitting function.....	17
5.3.3.2.3 Selection of MSC enhanced for SRVCC	17
5.3.3A SGSN	18
5.3.3A.1 Interworking with 3GPP MSC Server enhanced for SRVCC.....	18
5.3.3A.1.1 Interworking with 3GPP MSC Server enhanced for SRVCC.....	18
5.3.3A.1.2 PS bearer splitting function.....	18
5.3.3A.1.3 Selection of MSC enhanced for SRVCC	18
5.3.4 UE enhanced for SRVCC.....	18
5.3.4.1 Interworking with 3GPP2 1xCS	18
5.3.4.2 Interworking with 3GPP UTRAN/GERAN	18
5.3.5 Serving/PDN GW.....	19
5.3.6 E-UTRAN	19
5.3.6.1 Interworking with 3GPP2 1xCS	19
5.3.6.2 Interworking with 3GPP UTRAN/GERAN	19
5.3.6A UTRAN (HSPA)	19
5.3.7 HSS	19
5.3.7.1 Interworking with 3GPP UTRAN/GERAN	19
5.3.8 PCC.....	20
5.4 Reference points	20

5.4.1	MME – 3GPP2 1xCS IWS (S102)	20
5.4.2	MME/SGSN – MSC Server (Sv)	20
5.4.3	E-UTRAN – MME (S1-MME)	20
5.4.3A	UTRAN (HSPA) – SGSN (Iu-ps)	20
5.4.4	HSS – MME (S6a)	20
5.4.5	HSS – SGSN (Gr, S6d)	20
6	Procedures and flows	21
6.1	SRVCC from E-UTRAN to 3GPP2 1xCS	21
6.1.1	E-UTRAN Attach procedure for SRVCC	21
6.1.2	Service Request procedures for SRVCC	21
6.1.2A	PS Handover procedures for SRVCC	21
6.1.3	Call flows for SRVCC from E-UTRAN	21
6.2	E-UTRAN and 3GPP GERAN/UTRAN SRVCC	23
6.2.1	E-UTRAN Attach procedure for SRVCC	23
6.2.1A	Service Request procedures for SRVCC	24
6.2.1B	PS Handover procedures for SRVCC	24
6.2.2	Call flows for SRVCC from E-UTRAN	24
6.2.2.1	SRVCC from E-UTRAN to GERAN without DTM support	25
6.2.2.1A	SRVCC from E-UTRAN to GERAN with DTM but without DTM HO support and from E-UTRAN to UTRAN without PS HO	27
6.2.2.2	SRVCC from E-UTRAN to UTRAN with PS HO or GERAN with DTM HO support	28
6.3	UTRAN (HSPA) and 3GPP GERAN/UTRAN SRVCC	31
6.3.1	GPRS Attach procedure for SRVCC	31
6.3.1A	Service Request procedures for SRVCC	32
6.3.1B	PS Handover procedures for SRVCC	32
6.3.2	Call flows for SRVCC from UTRAN (HSPA)	32
6.3.2.1	SRVCC from UTRAN (HSPA) to GERAN without DTM support	32
6.3.2.1A	SRVCC from UTRAN (HSPA) to GERAN with DTM but without DTM HO support and from UTRAN (HSPA) to UTRAN without PS HO	35
6.3.2.2	SRVCC from UTRAN (HSPA) to UTRAN or GERAN with DTM HO support	35
7	Charging	39
8	Handover Failure	39
8.1	Failure in EUTRAN/UTRAN (HSPA) and 3GPP UTRAN/GERAN SR-VCC	39
8.1.1	Failure before MSC Server initiates Session Transfer	39
8.1.1a	Failure after MSC Server initiates Session Transfer	39
8.1.1a.1	Failure before responding to PS to CS HO request	39
8.1.1a.2	Failure after responding to PS to CS HO request	40
8.1.2	Failure after UE receives HO command	41
8.1.3	Handover Cancellation	41
9	Security	42
9.1	Network Domain Security with 3GPP2 1xCS IWS	42
9.2	Network Domain Security with 3GPP UTRAN/GERAN MSC Server	43
Annex A (informative): Determination of Neighbour Cell List		44
A.1	SRVCC from E-UTRAN to 3GPP2 1xCS	44
A.2	SRVCC from E-UTRAN to GERAN/UTRAN	44
A.3	SRVCC from UTRAN (HSPA) to GERAN/UTRAN	44
Annex B (informative): Change history		45

Foreword

This Technical Specification has been produced by the 3rd Generation Partnership Project (3GPP).

The contents of the present document are subject to continuing work within the TSG and may change following formal TSG approval. Should the TSG modify the contents of the present document, it will be re-released by the TSG with an identifying change of release date and an increase in version number as follows:

Version x.y.z

where:

- x the first digit:
 - 1 presented to TSG for information;
 - 2 presented to TSG for approval;
 - 3 or greater indicates TSG approved document under change control.
- y the second digit is incremented for all changes of substance, i.e. technical enhancements, corrections, updates, etc.
- z the third digit is incremented when editorial only changes have been incorporated in the document.

1 Scope

The present document specifies the architecture enhancements for Single Radio Voice Call Continuity (SRVCC) between E-UTRAN access and 3GPP2's 1xCS, and between E-UTRAN access and 3GPP's UTRAN/GERAN accesses and between UTRAN (HSPA) access and 3GPP's UTRAN/GERAN accesses, for Circuit Switched (CS) calls that are anchored in the IMS.

This document will not describe 3GPP2 functional entities. However, interfaces between both 3GPP and 3GPP2 functional entities are described in this specification.

SRVCC from E-UTRAN access to 3GPP2 1xCS is covered in this specification, including the handling of IMS emergency call continuity. Handling of non-voice component and SRVCC from 3GPP2 1xCS to E-UTRAN direction is not specified in this release.

SRVCC from E-UTRAN/UTRAN (HSPA) access to 3GPP UTRAN/GERAN CS accesses for voice calls that are anchored in the IMS, as well as the coordination between the SRVCC for voice call and the handover of non-voice PS bearers and the handling of IMS emergency call continuity, are covered in this specification. The handover of non-voice PS bearer from E-UTRAN is specified by the procedures defined in TS 23.401 [2], TS 23.060 [10], TS 25.413 [11] and TS 43.129 [12]. The handover of non voice PS bearer from UTRAN (HSPA) is specified by the procedures defined in TS 23.060 [10], TS 25.413 [11] and TS 43.129 [12]. Handling of SRVCC from 3GPP UTRAN/GERAN CS accesses to E-UTRAN/UTRAN (HSPA) direction is not specified in this release.

2 References

The following documents contain provisions which, through reference in this text, constitute provisions of the present document.

- References are either specific (identified by date of publication, edition number, version number, etc.) or non-specific.
- For a specific reference, subsequent revisions do not apply.
- For a non-specific reference, the latest version applies. In the case of a reference to a 3GPP document (including a GSM document), a non-specific reference implicitly refers to the latest version of that document *in the same Release as the present document*.

- [1] 3GPP TR 21.905: "Vocabulary for 3GPP Specifications".
- [2] 3GPP TS 23.401: "GPRS enhancements for E-UTRAN access".
- [3] 3GPP TS 23.402 "Architecture enhancements for non-3GPP accesses".
- [4] 3GPP2 X.S0042-0: "Voice Call Continuity between IMS and Circuit Switched System".
- [5] ITU-T Recommendation I.130: "Method for the characterization of telecommunication services supported by an ISDN and network capabilities of an ISDN".
- [6] ITU-T Recommendation Q.65: "Methodology - Stage 2 of the method for the characterisation of services supported by an ISDN".
- [7] 3GPP TR 36.938: "Improved Network Controlled Mobility between E-UTRAN and 3GPP2/Mobile WiMAX Radio Technologies".
- [8] 3GPP2 A.S0008-C: "Interoperability Specification (IOS) for High Rate Packet Data (HRPD) Radio Access Network Interfaces with Session Control in the Access Network".
- [9] 3GPP TS 22.278: "Service requirements for the Evolved Packet System (EPS)".
- [10] 3GPP TS 23.060: "General Packet Radio Service (GPRS); Service description; Stage 2".

- [11] 3GPP TS 25.413: "UTRAN Iu interface Radio Access Network Application Part (RANAP) signalling".
- [12] 3GPP TS 43.129: "Packet-switched handover for GERAN A/Gb mode; Stage 2".
- [13] 3GPP TS 23.292: "IP Multimedia Subsystem (IMS) Centralized Services: Stage 2".
- [14] 3GPP TS 23.237: "IP Multimedia Subsystem (IMS) Service Continuity: Stage 2".
- [15] 3GPP TS 23.002: "Network Architecture".
- [16] 3GPP TS 36.300: "Evolved Universal Terrestrial Radio Access (E-UTRA) and Evolved Universal Terrestrial Radio Access Network (E-UTRAN); Overall description; Stage 2".
- [17] Void.
- [18] 3GPP TS 23.009: "Handover procedures".
- [19] 3GPP TS 25.331: "Radio Resource Control (RRC) protocol specification".
- [20] 3GPP2 A.S0014: "Interoperability Specification (IOS) for cdma2000 Access Network Interfaces".
- [21] 3GPP TS 33.210: "3G Security; Network Domain Security; IP network layer security".
- [22] 3GPP TS 33.401: "3GPP System Architecture Evolution (SAE): Security architecture".
- [23] 3GPP TS 48.008: "Mobile Switching Centre - Base Station System (MSC-BSS) interface; Layer 3 specification".
- [24] 3GPP TS 48.018: "General Packet Radio Service (GPRS); Base Station System (BSS) - Serving GPRS Support Node (SGSN); BSS GPRS Protocol (BSSGP)".
- [25] 3GPP TS 33.102: "3G Security; Security architecture".
- [26] 3GPP TS 22.173: "IP Multimedia Core Network Subsystem (IMS) Multimedia Telephony Service and supplementary services".
- [27] 3GPP TS 23.003: "Numbering, addressing and identification".
- [28] 3GPP TS 23.167: "IP Multimedia Core Network Subsystem (IMS) emergency sessions".
- [29] 3GPP TS 23.271: "Functional stage 2 description of Location Services (LCS)".
- [30] 3GPP TS 36.413: "Evolved Universal Terrestrial Radio Access Network (E-UTRAN); S1 Application Protocol (S1AP)".
- [31] 3GPP TS 23.203: "Policy and charging control architecture".
- [32] 3GPP TS 36.423: "Evolved Universal Terrestrial Radio Access Network (E-UTRAN); X2 Application Protocol (X2AP)".
- [33] 3GPP TS 29.303: "Domain Name System Procedures; Stage 3".

3 Definitions and abbreviations

3.1 Definitions

For the purposes of the present document, the terms and definitions given in TR 21.905 [1] and the following apply. A term defined in the present document takes precedence over the definition of the same term, if any, in TR 21.905 [1].

1xCS: The 3GPP2 legacy circuit switched signalling system as defined in 3GPP2 X.S0042-0 [4].

3GPP SRVCC UE: A 3GPP SRVCC UE is a UE enhanced for IMS Service Continuity with the additional UE capabilities described in this specification for SRVCC between E-UTRAN and 3GPP UTRAN and / or between E-UTRAN and 3GPP GERAN and / or between UTRAN (HSPA) and 3GPP UTRAN and 3GPP GERAN.

Emergency Session Transfer Number for SR VCC (E-STN-SR): see TS 23.237 [14].

Single Radio Voice Call Continuity: Voice call continuity between IMS over PS access and CS access for calls that are anchored in IMS when the UE is capable of transmitting/receiving on only one of those access networks at a given time.

Session Transfer Number for SR-VCC (STN-SR): see TS 23.237 [14].

Correlation MSISDN: An MSISDN used for correlation of sessions. See TS 23.003 [27] for more information.

3.3 Abbreviations

For the purposes of the present document, the abbreviations given in TR 21.905 [1] and the following apply. An abbreviation defined in the present document takes precedence over the definition of the same abbreviation, if any, in TR 21.905 [1].

SRVCC	Single Radio Voice Call Continuity
1xCS IWS	Single Radio Voice Call Continuity Interworking solution Function for 3GPP2 1xCS
SAI	Serving Area Identity as defined in TS 25.413 [11]
C-MSISDN	Correlation MSISDN

4 High level Principles and Concepts

4.1 High level Principles

4.1.1 Architectural Principles for 3GPP2 1xCS SRVCC

The solution for SRVCC fulfils the requirements of TS 22.278 [9] and the following architectural principles:

1. The solution shall allow coexistence and be compatible with the 1xCS procedures specified in the 3GPP2 VCC specification, X.S0042 [4].
2. The solution shall not require UE with multiple RATs capability to simultaneously signal on two different RATs.
3. The solution shall be transparent to E-UTRA only terminal or network.
4. The solution shall minimize the coupling between the E-UTRAN and the 3GPP2 access. In particular, the solution shall allow the cdma2000 1xRTT specification to evolve without necessitating a modification to the E-UTRAN specifications.
5. RAT change and domain selection should be under network control.
6. In roaming cases, the Visited PLMN should control the RAT change and/or domain selection while taking into account any related HPLMN policies.
7. The solution shall not impact cdma2000 RAT.
8. The solution shall not impact cdma2000 CS CN.
9. All IMS sessions that may be subject to SRVCC shall be anchored in the IMS (VCC Application).
10. When SRVCC is deployed, QCI=1:
 - shall not be used for IMS sessions that are not anchored in the IMS (VCC Application); and
 - shall only be used for the voice bearer.

4.1.2 Architectural Principles for 3GPP UTRAN/GERAN SRVCC

The solution for SRVCC fulfils the requirements of TS 22.278 [9] and the following architectural principles:

1. The solution shall allow coexistence and be compatible with TS 23.292 [13] and TS 23.237 [14].
2. The solution shall not require UE with multiple RATs capability to simultaneously signal on two different RATs.
3. RAT change and domain selection should be under network control.
4. E-UTRAN/UTRAN (HSPA) to UTRAN/GERAN handover for SRVCC is triggered by the same radio handover conditions and mechanisms as for an E-UTRAN/UTRAN (HSPA) to UTRAN/GERAN PS handover.
5. All IMS sessions that may be subject to SRVCC shall be anchored in the IMS (SCC AS).
6. When SRVCC is deployed, QCI=1 / traffic-class conversation with source statistics descriptor = "speech":
 - shall not be used for IMS sessions that are not anchored in the IMS (SCC AS); and
 - shall only be used for the voice bearer.

NOTE: The UE may have multiple voice media streams that are multiplexed over a single voice (e.g. QCI=1) bearer. Selection of the voice streams for SRVCC by the SCC AS is as specified in TS 23.237 [14].

4.2 Concepts

4.2.1 E-UTRAN and 3GPP2 1xCS SRVCC

For SRVCC-capable UEs, the call is always anchored at the VCC AS in the 3GPP2's IMS. The 3GPP2 1xCS IWS enables a single radio UE to communicate in parallel both with the source system and the target system. From VCC perspective, this mechanism minimizes the voice gap by supporting the transport of signalling for establishment of the target CS access leg while the terminal is connected to the source PS access network.

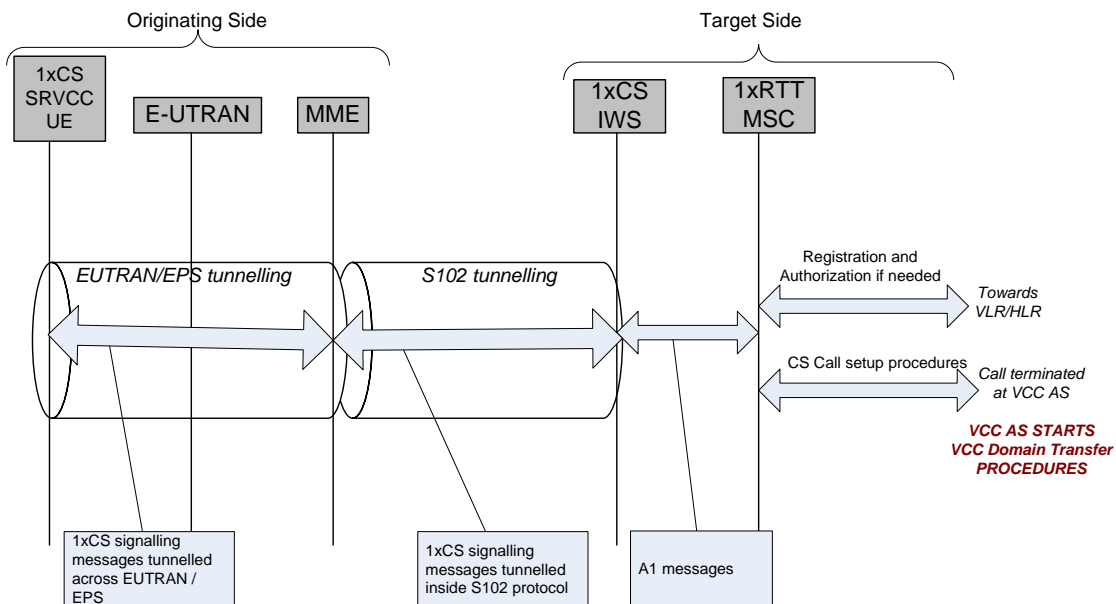

Figure 4.2.1-1: Transport of 3GPP2 1xCS signalling messages for preparation of the CS access leg in the target system

The S102 reference point is used to convey 3GPP2 1xCS signalling messages between the MME and 3GPP2 1xCS IWS. These 1x CS signalling messages are actually exchanged between the UE and the 3GPP2 1xCS IWS, and S102 is only one link in the overall UE-1xCS IWS tunnelling path. On the remaining portion of the tunnelling path, the 3GPP2 1xCS signalling messages are encapsulated in E-UTRAN/EPS tunnelling messages (UE-MME).

4.2.2 E-UTRAN and 3GPP UTRAN/GERAN SRVCC

For facilitating session transfer (SRVCC) of the voice component to the CS domain, the IMS multimedia telephony sessions needs to be anchored in the IMS.

For SRVCC from E-UTRAN to UTRAN/GERAN, MME first receives the handover request from E-UTRAN with the indication that this is for SRVCC handling, and then triggers the SRVCC procedure with the MSC Server enhanced with SRVCC via the Sv reference point if MME has SRVCC STN-SR information for this UE. MSC Server enhanced for SRVCC then initiates the session transfer procedure to IMS and coordinates it with the CS handover procedure to the target cell. MSC Server enhanced for SRVCC then sends PS-CS handover Response to MME, which includes the necessary CS HO command information for the UE to access the UTRAN/GERAN.

Handling of any non-voice PS bearer is done by the PS bearer splitting function in the MME. MME starts the handover of non-voice PS bearer during SRVCC procedure based on the information received from E-UTRAN. The handover of non-voice PS bearer(s), if performed, is done as according to Inter RAT handover procedure as defined in TS 23.401 [2]. The MME is responsible to coordinate the Forward Relocation Response from PS-PS handover procedure and the SRVCC PS to CS Response.

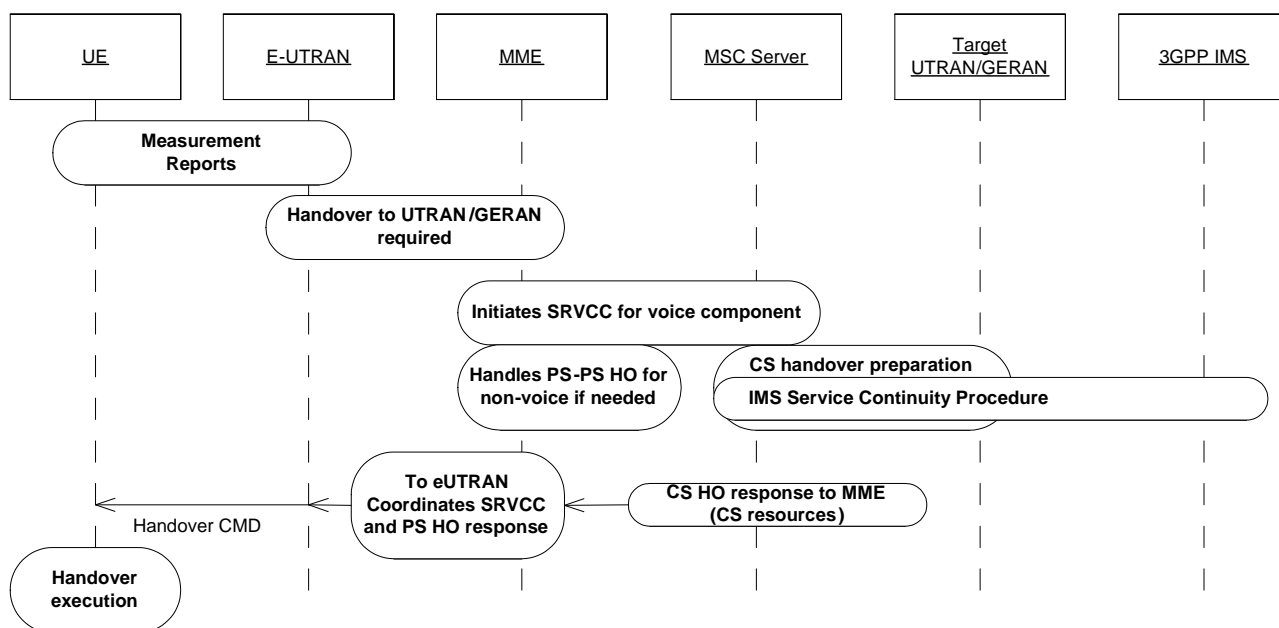

Figure 4.2.2-1: Overall high level concepts for SRVCC from E-UTRAN to UTRAN/GERAN

4.2.3 UTRAN (HSPA) to 3GPP UTRAN/GERAN SRVCC

For facilitating session transfer (SRVCC) of the voice component to the CS domain, the IMS multimedia telephony sessions needs to be anchored in the IMS.

For SRVCC from UTRAN (HSPA) to UTRAN/GERAN, SGSN first receives the handover request from UTRAN (HSPA) with the indication that this is for SRVCC handling, and then triggers the SRVCC procedure with the MSC Server enhanced with SRVCC via the Sv if SGSN has STN-SR information for this UE. MSC Server enhanced for SRVCC then initiates the session transfer procedure to IMS and coordinates it with the CS handover procedure to the target cell. MSC Server enhanced for SRVCC then sends PS-CS handover Response to SGSN, which includes the necessary CS HO command information for the UE to access the UTRAN/GERAN.

Handling of any non voice PS bearer is done by the PS bearer splitting function in the SGSN. SGSN starts the handover of non voice PS bearer during SRVCC procedure based on the information received from UTRAN (HSPA). The handover of non voice PS bearer(s), if performed, is done as according to Inter/Intra RAT handover procedure as defined in TS 23.060 [10] and TS 25.413 [11]. The SGSN is responsible to coordinate the Forward Relocation Response from PS-PS handover procedure and the SRVCC PS to CS Response.

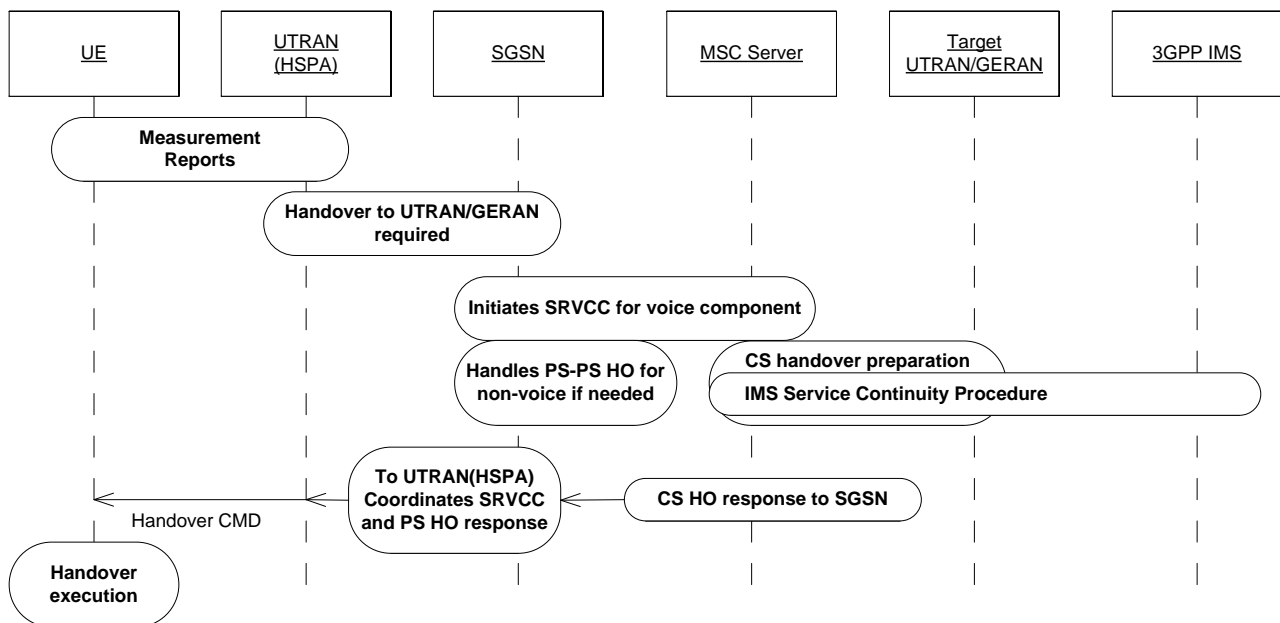

Figure 4.2.3-1: Overall high level concepts for SRVCC from UTRAN (HSPA) to UTRAN/GERAN

4.2.4 SRVCC for IMS emergency sessions

4.2.4.1 E-UTRAN/UTRAN (HSPA) to 3GPP UTRAN/GERAN

UE initiates the IMS emergency session as specified in TS 23.167 [28], TS 23.401 [2] for E-UTRAN or TS 23.060 [10] for UTRAN (HSPA). For facilitating session transfer (SRVCC) of the IMS emergency session to the CS domain, the IMS emergency session needs to be anchored in the serving IMS (i.e., in visited PLMN when roaming) as specified in TS 23.237 [14].

The E-UTRAN initiates the SRVCC procedure as specified for regular Voice over IMS session. The MME is aware that this is an emergency session and sends an indication to the MSC Server enhanced for SRVCC. MSC Server then initiates the IMS service continuity procedure with the locally configured E-STN-SR to the serving IMS. When handover of the emergency session has been completed, the MME/SGSN or the MSC server may initiate location continuity procedures for the UE as defined in TS 23.271 [29].

NOTE: Procedure for multiple E-STN-SRs configuration is not defined in this release. The serving PLMN is assumed to have a single logical EATF (i.e. single I4 in TS 23.237 [14]).

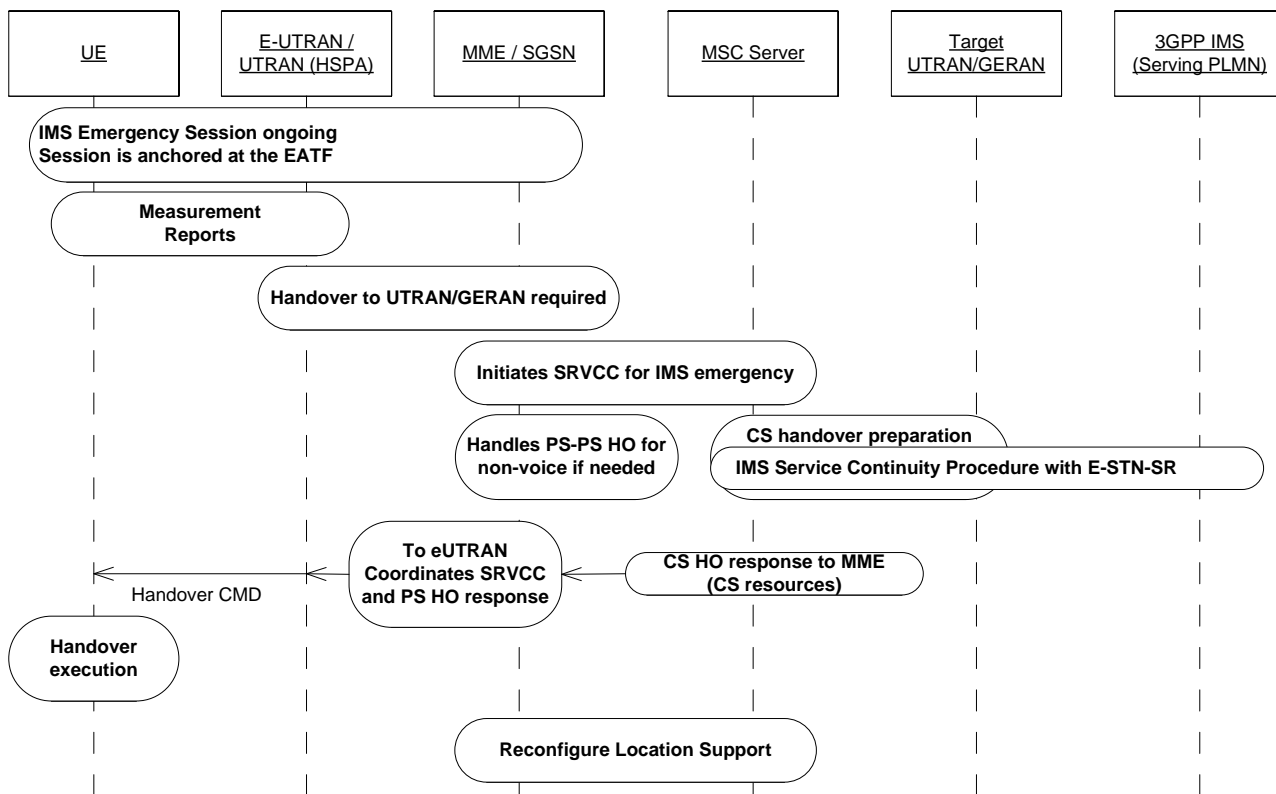

Figure 4.2.4.1-1: Overall high level concepts for SRVCC IMS emergency session with E-STN-SR

4.2.4.2 E-UTRAN to 3GPP2 1xCS

The UE initiates emergency session over E-UTRAN as specified in TS 23.167 [28], TS 23.401 [2], upon detecting handover is required from E-UTRAN to CDMA 1x, the SRVCC emergency procedure apply. To support handover of emergency session the network is aware that the UE and core network support SRVCC and has information to identify Emergency session. When handover of the emergency session has been completed, the MME or the 1xRTT side may initiate location continuity procedures for the UE as defined in TS 23.271 [29].

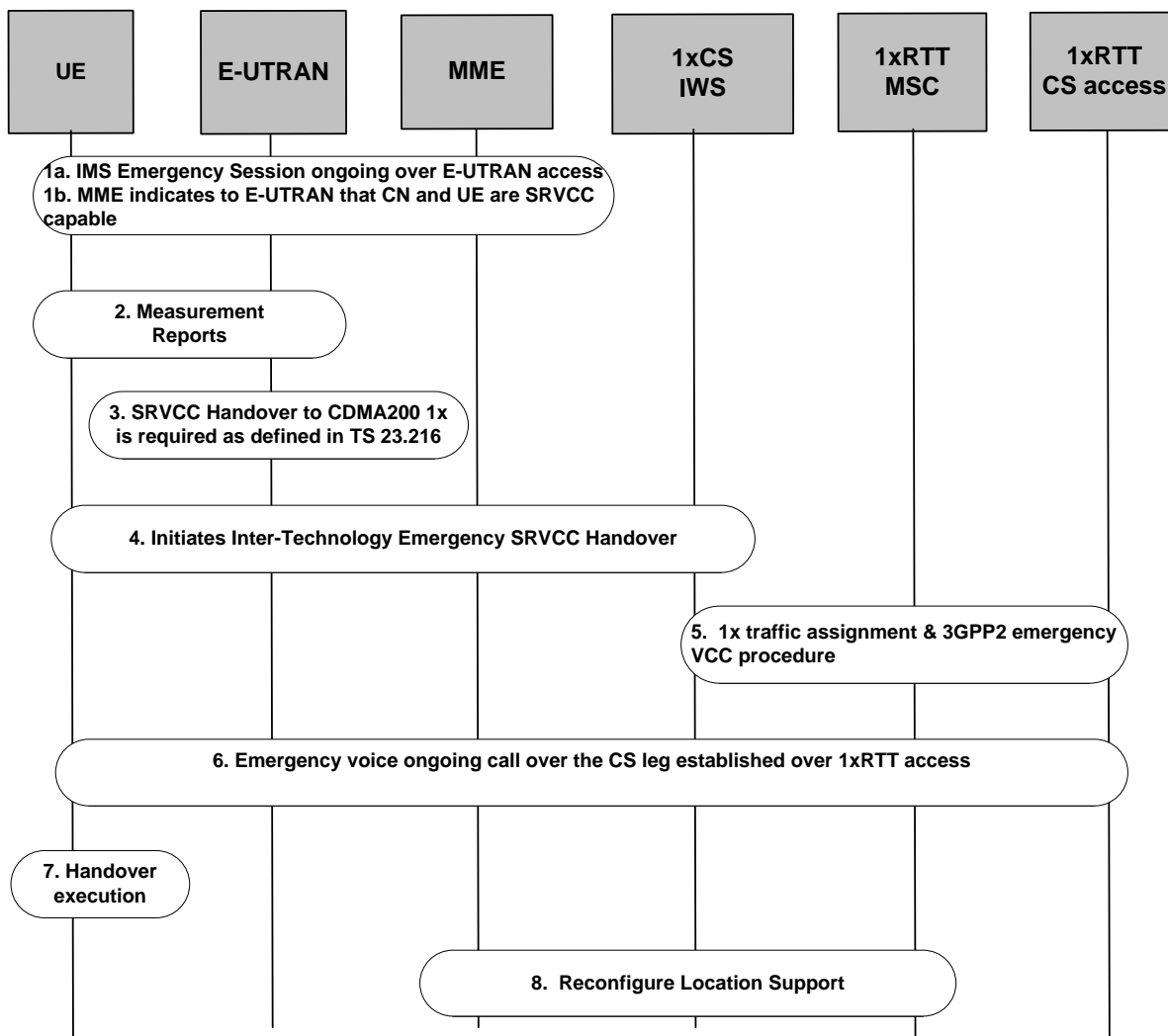

Figure 4.2.4.2-1: E-UTRAN to 3GPP2 1xCS

4.2.4.3 SRVCC in Limited Service Mode

4.2.4.3.1 E-UTRAN/UTRAN (HSPA) to 3GPP UTRAN/GERAN

In order to support SRVCC emergency session domain transfer for UEs in Limited Service Mode (e.g. UICC-less), the MME/SGSN shall support Limited Service Mode UE emergency attach defined in TS 23.401 [2] and TS 23.060 [10] using unauthenticated IMSI or equipment identifier.

When E-UTRAN/UTRAN determines that SRVCC is needed, the MME/SGSN invokes SRVCC procedures to the MSC Server including the UE's equipment identifier. The MSC Server will setup the call leg towards the EATF with the UE's equipment identifier. This procedure is defined in TS 23.237 [14].

4.2.4.3.2 E-UTRAN to 3GPP2 1xCS

In order to support SRVCC emergency session domain transfer for UEs in Limited Service Mode (e.g. UICC-less), the MME shall support Limited Service Mode UE emergency attach defined in TS 23.401 [2] using unauthenticated IMSI or equipment identifier.

When E-UTRAN determines that SRVCC is needed, the MME invokes SRVCC procedures to the 1xCS IWS including the UE's equipment identifier.

5 Architecture model and reference points

5.1 General

The SRVCC Architecture for 3GPP2 1xCS reuses many existing elements in 3GPP2 X.S0042 [4] for 3GPP2 1xCS.

The SRVCC Architecture for 3GPP UTRAN/GERAN reuses the session transfer function defined for IMS in TS 23.237 [14] for IMS service continuity. The MSC Server that is enhanced for SRVCC may also be enhanced for ICS as defined in TS 23.292 [13].

The overall model and impacts to the various elements is provided in the following clauses.

5.2 Reference architecture

5.2.1 E-UTRAN and 3GPP2 1xCS SRVCC architecture

This specification introduces an additional functional entity to those defined in the E-UTRAN architecture TS 23.402 [3], called 1x CS SRVCC interworking solution function (3GPP2 1xCS IWS), see figure 5.2.1-1.

NOTE: The figure only shows the necessary components related to 3GPP2 1xCS IWS.

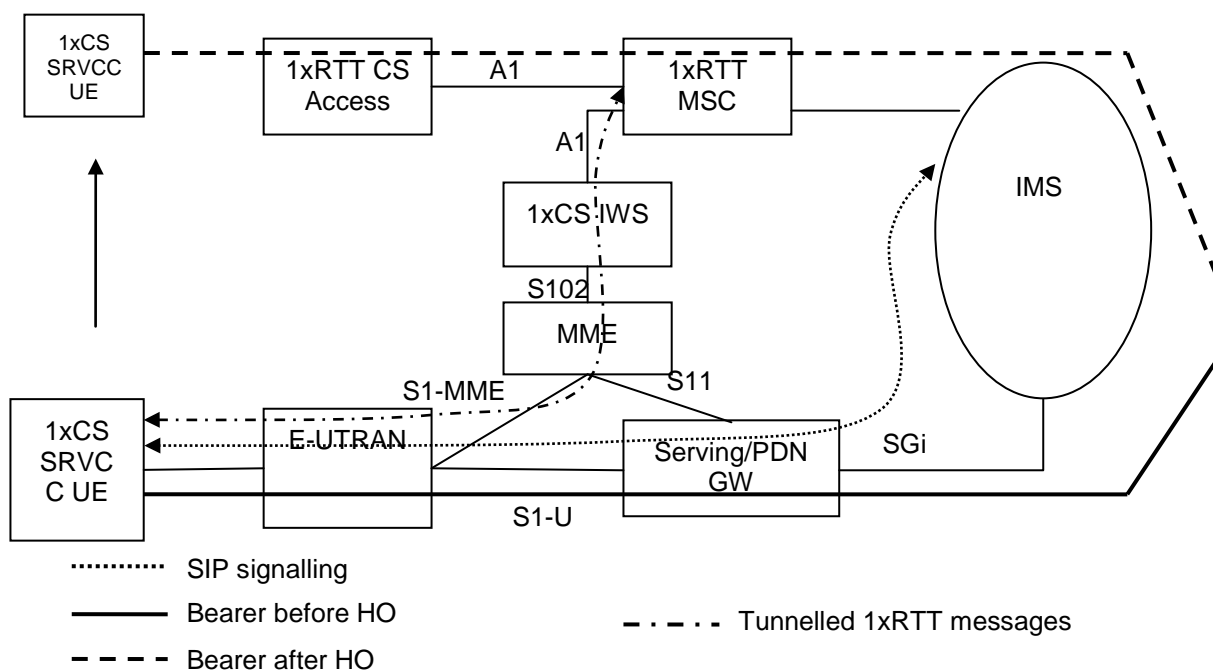
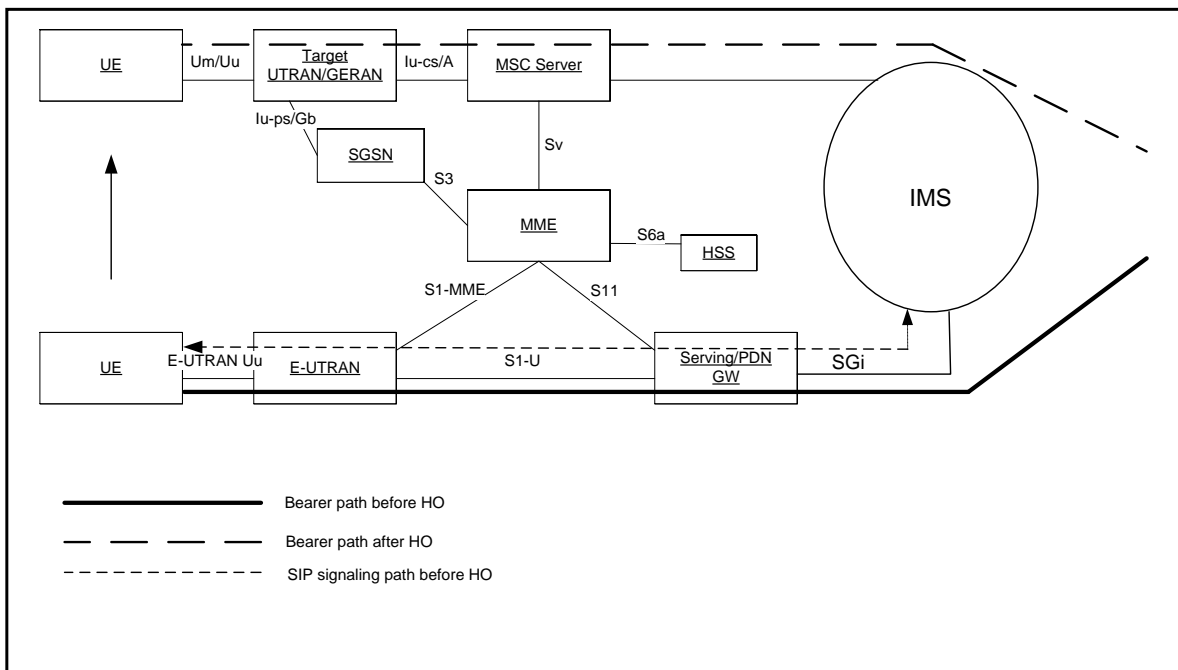

Figure 5.2.1-1: SRVCC architecture for E-UTRAN to 3GPP2 1xCS

5.2.2 E-UTRAN and 3GPP UTRAN/GERAN SRVCC architecture

This specification introduces an additional function to those defined in the E-UTRAN architecture TS 23.401 [2] for SRVCC. This additional function is provided by the MSC Server (i.e., MSC Server enhanced for SRVCC).

NOTE 1: The following figure only shows the necessary components related to MSC Server enhanced with SRVCC.



NOTE 2: MSC Server shown in the figure is enhanced for SRVCC.
 NOTE 3: This architecture also applies to roaming scenario (i.e., S8, S6a are not impacted due to SRVCC).
 NOTE 4: The MSC server enhanced with SRVCC may not be the final target MSC which connects to the target cell.

Figure 5.2.2-1: SRVCC architecture for E-UTRAN to 3GPP UTRAN/GERAN

5.2.3 UTRAN (HSPA) and 3GPP UTRAN/GERAN SRVCC architecture

This specification introduces an additional function to those defined in the UTRAN architecture TS 23.060 [10] for SRVCC. This additional function is provided by the MSC Server (i.e., MSC Server enhanced for SRVCC).

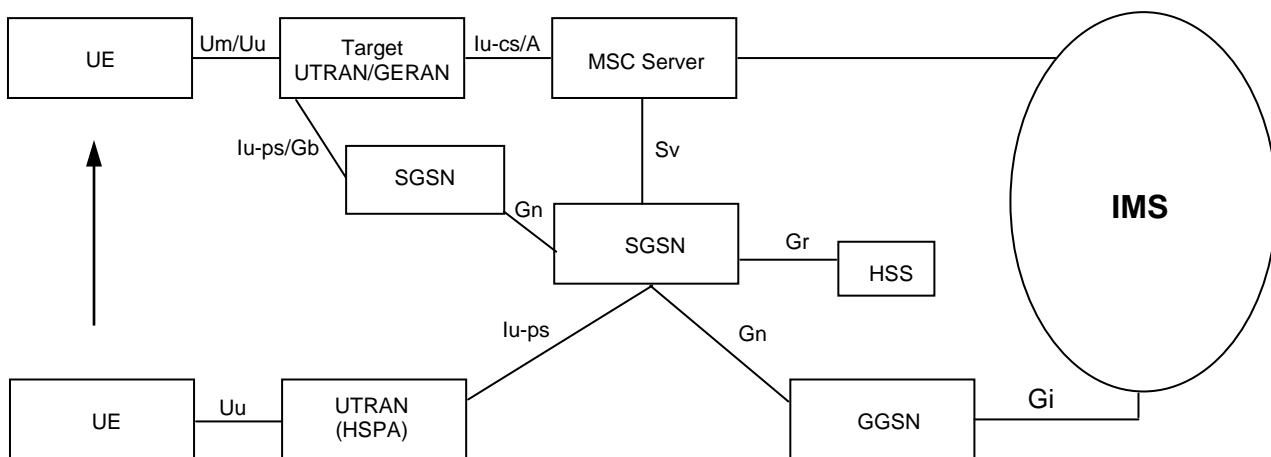
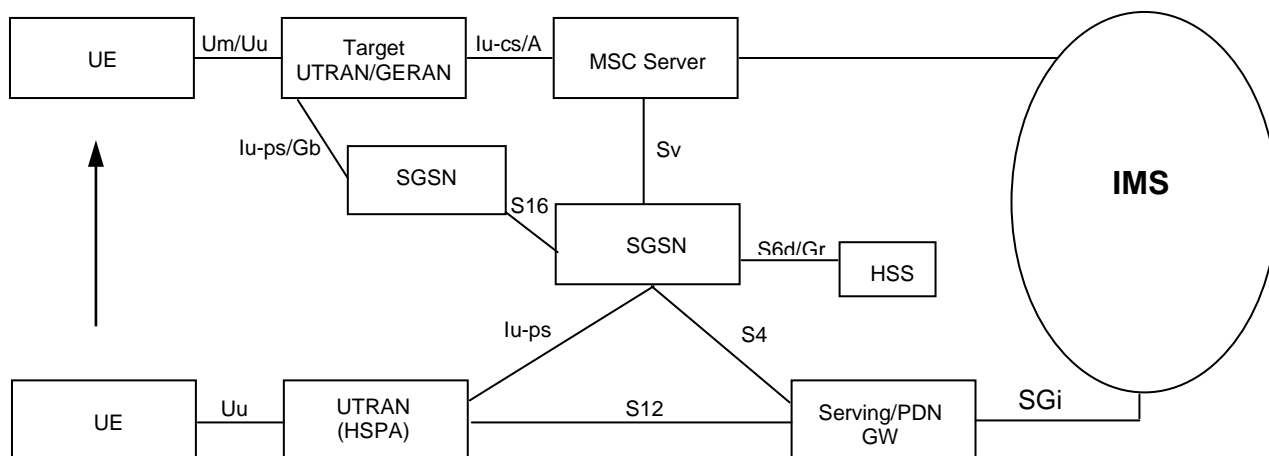

Figure 5.2.3-1: SRVCC architecture for UTRAN (HSPA) to 3GPP UTRAN/GERAN with Gn based SGSN



NOTE 1: The above figures only show the necessary components related to MSC Server enhanced with SRVCC.

NOTE 2: MSC Server shown in the above figures are enhanced for SRVCC.

NOTE 3: This architecture also applies to roaming scenario.

NOTE 4: The MSC server enhanced with SRVCC may not be the final target MSC which connects to the target cell.

Figure 5.2.3-2: SRVCC architecture for UTRAN (HSPA) to 3GPP UTRAN/GERAN with S4 based SGSN

5.3 Functional Entities

NOTE 1: 3GPP2 components are not described here. Please refer to 3GPP2 X.S0042 [4].

NOTE 2: IMS components are not described here. Please refer to TS 23.237 [14] and TS 23.292 [13].

5.3.1 3GPP2 1x CS SRVCC interworking solution function (1xCS IWS)

3GPP2 1xCS IWS uses the S102 reference point to communicate with the MME and to transport 3GPP2 1xCS signalling messages to the SRVCC UE. The role of the 3GPP2 1xCS IWS is:

- To be a signalling tunnelling end point towards the MME for receiving/sending encapsulated 3GPP2 1xCS signalling messages to/from the UE; and
- To emulate a 1xRTT BSS towards the 1xRTT MSC (reference point A1 as defined in 3GPP2 A.S0014 [20] between 1xBS and MSC).

5.3.2 MSC Server enhanced for E-UTRAN/UTRAN (HSPA) and 3GPP UTRAN/GERAN SRVCC

In addition to the standard MSC Server behavior defined in TS 23.002 [15], an MSC Server which has been enhanced for SRVCC provides the following functions as needed for support of SRVCC:

- Handling the Relocation Preparation procedure requested for the voice component from MME/SGSN via Sv reference point;
- Behaving as MSC Server enhanced for ICS as defined in TS 23.292 [13] if supported and when ICS flag is received via Sv reference point is set to true and optionally if the MSC Server is configured to know that the VPLMN has a suitable roaming agreement with the HPLMN of the UE;
- Invoking the session transfer procedure or emergency session transfer procedure from IMS to CS as according to TS 23.237 [14];
- Coordinating the CS Handover and session transfer procedures;
- Handling the MAP_Update_Location procedure without it being triggered from the UE;
- In case of an emergency session, conditionally sending a MAP Subscriber Location Report to a GMLC to support location continuity according to TS 23.271 [29].

5.3.3 MME

5.3.3.1 Interworking with 3GPP2 1xCS IWS

5.3.3.1.1 Interworking with 3GPP2 1xCS IWS

If the MME (operator) supports interworking to 3GPP2 1xCS, the MME shall follow the rules and procedures described in TS 23.402 [3] with the following additions and clarifications:

- To be a signalling tunnelling end point towards the 3GPP2 1xCS IWS for sending/receiving encapsulated 3GPP2 1xCS signalling messages to/from the UE, which are encapsulated in S1-MME S1 Information Transfer messages (TR 36.938 [7]).
- release of the E-UTRAN resources after SRVCC to the 3GPP2 1xCS is completed.
- include information to enable 3GPP2 network to determine emergency session.
- insert the equipment identifier during the handover procedure for the case UE operating in limited service mode.

5.3.3.1.2 Selection of 3GPP2 1xCS IWS

The 3GPP2 1xCS IWS can be selected based on the local configuration in the MME taking into account the Reference CellID received in the Uplink S1 cdma2000 Tunnelling message,

5.3.3.2 Interworking with 3GPP MSC Server enhanced for SRVCC

5.3.3.2.1 Interworking with 3GPP MSC Server enhanced for SRVCC

If the MME (operator) supports the interworking to 3GPP CS, the MME shall follow the rules and procedures described in TS 23.401 [2] with the following additions and clarifications:

- Performing the PS bearer splitting function by separating the voice PS bearer from the non-voice PS bearers.
- Handling the non-voice PS bearers handover with the target cell as according to Inter RAT handover procedure as defined in TS 23.401 [2].
- Initiating the SRVCC handover procedure for handover of the voice component to the target cell via the Sv interface and including an emergency indication if this is an emergency session. If there are multiple voice bearers and one of those is for IMS emergency session then MME shall only execute the SRVCC for emergency.

NOTE: The UE may have 2 voice PS bearers if both emergency and normal IMS voice sessions are ongoing. Only the PS voice bearer associated with IMS emergency session will be executed for SRVCC.

- Coordinating PS handover and SRVCC handover procedures when both procedures are performed.
- Sending the equipment identifier to the MSC Server during the handover procedure for the case of UEs operating in limited service mode.
- In case of an emergency session, conditionally sending a Subscriber Location Report to a GMLC to support location continuity according to TS 23.271 [29].

5.3.3.2.2 PS bearer splitting function

The function identifies the voice PS bearer upon E-UTRAN to UTRAN/GERAN SRVCC and performs different handling of this bearer from the non-voice PS bearers (see detailed procedures in subsequent clauses).

5.3.3.2.3 Selection of MSC enhanced for SRVCC

The MSC enhanced for SRVCC can be selected based on DNS procedures (see TS 29.303 [33]) or local configuration in the MME.

5.3.3A SGSN

5.3.3A.1 Interworking with 3GPP MSC Server enhanced for SRVCC

5.3.3A.1.1 Interworking with 3GPP MSC Server enhanced for SRVCC

If the SGSN (operator) supports the interworking to 3GPP CS, the SGSN shall follow the rules and procedures described in TS 23.060 [10] with the following additions and clarifications:

- Performing the PS bearer splitting function by separating the voice PS bearer from the non-voice PS bearers. VoIP is detected by traffic class=conversational and SSD='speech'.
- Handling the non-voice PS bearers handover with the target cell as according to Inter/Intra RAT handover procedure as defined in TS 23.060 [10].
- Initiating the SRVCC handover procedure for handover of the voice component to the target cell via the Sv interface and including an emergency indication if this is an emergency session. If there are multiple voice bearers and one of those is for IMS emergency session then SGSN shall only execute the SRVCC for emergency.

NOTE: The UE may have 2 voice PS bearers if both emergency and normal IMS voice sessions are ongoing. Only the PS voice bearer associated with IMS emergency session will be executed for SRVCC.

- Coordinating PS handover and SRVCC handover procedures when both procedures are performed.
- Sending the equipment identifier to the MSC Server during the handover procedure for the case of UEs operating in limited service mode.
- In case of an emergency session, conditionally sending a MAP Subscriber Location Report to a GMLC to support location continuity according to TS 23.271 [29].

5.3.3A.1.2 PS bearer splitting function

The function identifies the voice PS bearer upon HSPA to UTRAN/GERAN SRVCC and performs different handling on this bearer from the non-voice PS bearers (see detailed procedures in subsequent clauses).

5.3.3A.1.3 Selection of MSC enhanced for SRVCC

The MSC enhanced for SRVCC can be selected based on DNS procedures (see TS 29.303 [33]) or local configuration in the SGSN.

5.3.4 UE enhanced for SRVCC

5.3.4.1 Interworking with 3GPP2 1xCS

If the UE supports 3GPP2 1xCS access, the 1xCS SRVCC UE is a UE that is capable to perform SRVCC to the 3GPP2 1xCS system. The interaction between UE and E-UTRAN is described in TR 36.938 [7]. The interaction with the 3GPP2 1xCS system is described in this specification.

5.3.4.2 Interworking with 3GPP UTRAN/GERAN

3GPP SRVCC UE is needed to perform SRVCC (see clause 3.1 for 3GPP SRVCC UE definition). The interaction between UE and E-UTRAN is described in TS 36.300 [16] and between UE and UTRAN (HSPA) is described in TS 25.331 [19].

The SRVCC UE indicates to the network that the UE is SRVCC capable when being configured for using IMS speech service supported by the home operator, e.g. the IMS Multimedia Telephony Service for bi-directional speech as described in TS 22.173 [26] and the operator policy on the SRVCC UE as specified in TS 23.237 [14] does not restrict the session transfer.

5.3.5 Serving/PDN GW

No additional requirement due to SRVCC.

NOTE: If SRVCC is deployed and PCC is not used then the PDN GW is not able to enforce the architecture principle to use QCI=1, see clauses 4.1.1 and 4.1.2.

5.3.6 E-UTRAN

5.3.6.1 Interworking with 3GPP2 1xCS

If the E-UTRAN (operator) supports interworking to 3GPP2 1xCS, the E-UTRAN performs the HO trigger, tunnelling of the 3GPP2 1xCS signalling messages toward the MME, and interacting with the SRVCC UE as described in TR 36.938 [7].

E-UTRAN may be capable of determining the neighbour cell list based on the "SRVCC operation possible" indication and/or presence of an established QCI=1 bearer for a specific UE. An example algorithm is provided in clause A.1.

NOTE: If E-UTRAN does not update the neighbour cell list dynamically, if E-UTRAN triggers handover to 1x when either the "SRVCC operation possible" indication is set to "false" or there is no established QCI=1 bearer for a specific UE, this will result in an error case.

5.3.6.2 Interworking with 3GPP UTRAN/GERAN

Between UE and E-UTRAN, no additional functionality is required for the E-UTRAN as defined in TS 36.300 [16].

When E-UTRAN selects a target cell for SRVCC handover, it needs to send an indication to MME that this handover procedure requires SRVCC

E-UTRAN may be capable of determining the neighbour cell list based on the "SRVCC operation possible" indication and/or presence of an established QCI=1 bearer for a specific UE. An example algorithm is provided in clause A.2.

NOTE: In case E-UTRAN does not update the neighbour cell list dynamically, if E-UTRAN triggers handover to a VoIP-incapable cell when the "SRVCC operation possible" indication is set to "false" and there is an established voice (QCI=1) bearer for a specific UE, the establishment of the voice bearers will be rejected by the target access.

5.3.6A UTRAN (HSPA)

When HSPA capable UTRAN selects a target cell for SRVCC handover, it needs to send an indication to SGSN that this handover procedure requires SRVCC.

NOTE 1: UTRAN (HSPA) assumes that SGSN supports SRVCC functionality.

UTRAN may be capable of determining the neighbour cell list based on the "SRVCC operation possible" indication and/or presence of an established voice bearer (i.e. bearer with Traffic Class = Conversational and Source Statistic Descriptor = 'speech') for a specific UE. An example algorithm is provided in clause A.3.

NOTE 2: In case UTRAN does not update the neighbour cell list dynamically, if UTRAN triggers handover to a VoIP-incapable cell when the "SRVCC operation possible" indication is set to "false" and there is an established bearer with Traffic Class = Conversational and Source Statistic Descriptor = 'speech' for a specific UE, the establishment of the voice bearer will be rejected by the target access.

5.3.7 HSS

5.3.7.1 Interworking with 3GPP UTRAN/GERAN

The SRVCC STN-SR, C-MSISDN, and optional ICS flag per VPLMN, for the subscriber are downloaded to MME from HSS during E-UTRAN attach procedure. For UTRAN (HSPA), these subscription information are downloaded to SGSN from HSS during GPRS attach procedure. HSS also informs the MME/SGSN when STN-SR is modified or removed from the subscription.

The ICS flag is used by the MSC Server enhanced for SRVCC to behave also as MSC Server enhanced for ICS in TS 23.292 [13] if supported by the network.

NOTE: HSS functionality is not impacted when MSC Server enhanced with SRVCC performs the MAP_Update_Location procedure.

5.3.8 PCC

The PCRF enforces the architecture principle to use QCI=1 (and traffic-class conversational with source statistics descriptor ="speech") for voice bearer with IMS sessions anchored in the SCC AS, based on the service the session relates to. This may be achieved by deploying S9 reference point, or configuration and roaming agreements.

The PCEF should enforce to multiplex the media streams from multiple concurrent normal voice sessions.

NOTE: In this Release the UE initiated PDP context for voice bearer is not supported.

5.4 Reference points

5.4.1 MME – 3GPP2 1xCS IWS (S102)

The S102 reference point provides a tunnel between MME and 3GPP2 1xCS IWS to relay 3GPP2 1xCS signalling messages. 1x CS signalling messages are those messages that are defined for A21 interface as described in 3GPP2 A.S0008-C [8].

NOTE: It is up to stage 3 to determine whether the tunnelling protocol for S102 can be defined as exactly as in A21. If so, S102 is then equivalent to A21.

5.4.2 MME/SGSN – MSC Server (Sv)

The Sv reference point provides SRVCC support between 3GPP E-UTRAN/UTRAN (HSPA) and 3GPP UTRAN/GERAN.

MME/SGSN includes the optional ICS flag if received from the HSS.

5.4.3 E-UTRAN – MME (S1-MME)

For 3GPP2 1xCS SRVCC, the S1-MME reference point provides S1 Information Transfer message (TR 36.938 [7]) between UE and MME to relay the 3GPP2 1xCS signalling messages.

For 3GPP SRVCC, the S1-MME reference point allows handover signalling between E-UTRAN and MME. It is defined in TS 36.300 [16]

5.4.3A UTRAN (HSPA) – SGSN (Iu-ps)

For 3GPP HSPA SRVCC, the Iu-ps reference point allows handover signalling between UTRAN and SGSN. It is defined in TS 25.413 [11].

5.4.4 HSS – MME (S6a)

For 3GPP SRVCC, the S6a is used to download SRVCC related information to MME during E-UTRAN attach procedure or to inform MME that STN-SR information in the HSS has changed.

5.4.5 HSS – SGSN (Gr, S6d)

For 3GPP SRVCC, either the Gr or the S6d is used to download SRVCC related information to SGSN during UTRAN (HSPA) attach procedure or to inform SGSN that STN-SR information in the HSS has changed.

6 Procedures and flows

6.1 SRVCC from E-UTRAN to 3GPP2 1xCS

6.1.1 E-UTRAN Attach procedure for SRVCC

E-UTRAN attach or emergency attach procedure for 3GPP2 SRVCC UE is performed as defined in TS 23.401 [2] with the following additions:

- SRVCC UE includes the SRVCC capability indication as part of the "UE Network Capability" in the Attach Request message. MME stores this information for SRVCC operation.
- SRVCC UE capable for IMS emergency calls shall include the SRVCC capability indication as part of the UE network capability in the Emergency Attach Request message. MME stores this information for emergency SRVCC operation.
- MME includes a "SRVCC operation possible" indication in the S1 AP Initial Context Setup Request, meaning that both UE and MME are SRVCC-capable.

6.1.2 Service Request procedures for SRVCC

Service Request procedures for 3GPP2 SRVCC UE are performed as defined in TS 23.401 [2] with the following additions:

- MME includes a "SRVCC operation possible" indication in the S1 AP Initial Context Setup Request, meaning that both UE and MME are SRVCC-capable.

6.1.2A PS Handover procedures for SRVCC

Intra-E-UTRAN S1-based handover procedures for 3GPP2 SRVCC UE are performed as defined in TS 23.401 [2] with the following additions:

- The target MME includes a "SRVCC operation possible" indication in the S1-AP Handover Request message, meaning that both UE and the target MME are SRVCC-capable.

For X2-based handover, the source eNodeB includes a "SRVCC operation possible" indication in the X2-AP Handover Request message to the target eNodeB as specified in TS 36.423 [32].

6.1.3 Call flows for SRVCC from E-UTRAN

Figure 6.1.3-1 illustrates a high-level call flow for the E-UTRAN-to-1x voice service continuity procedure.

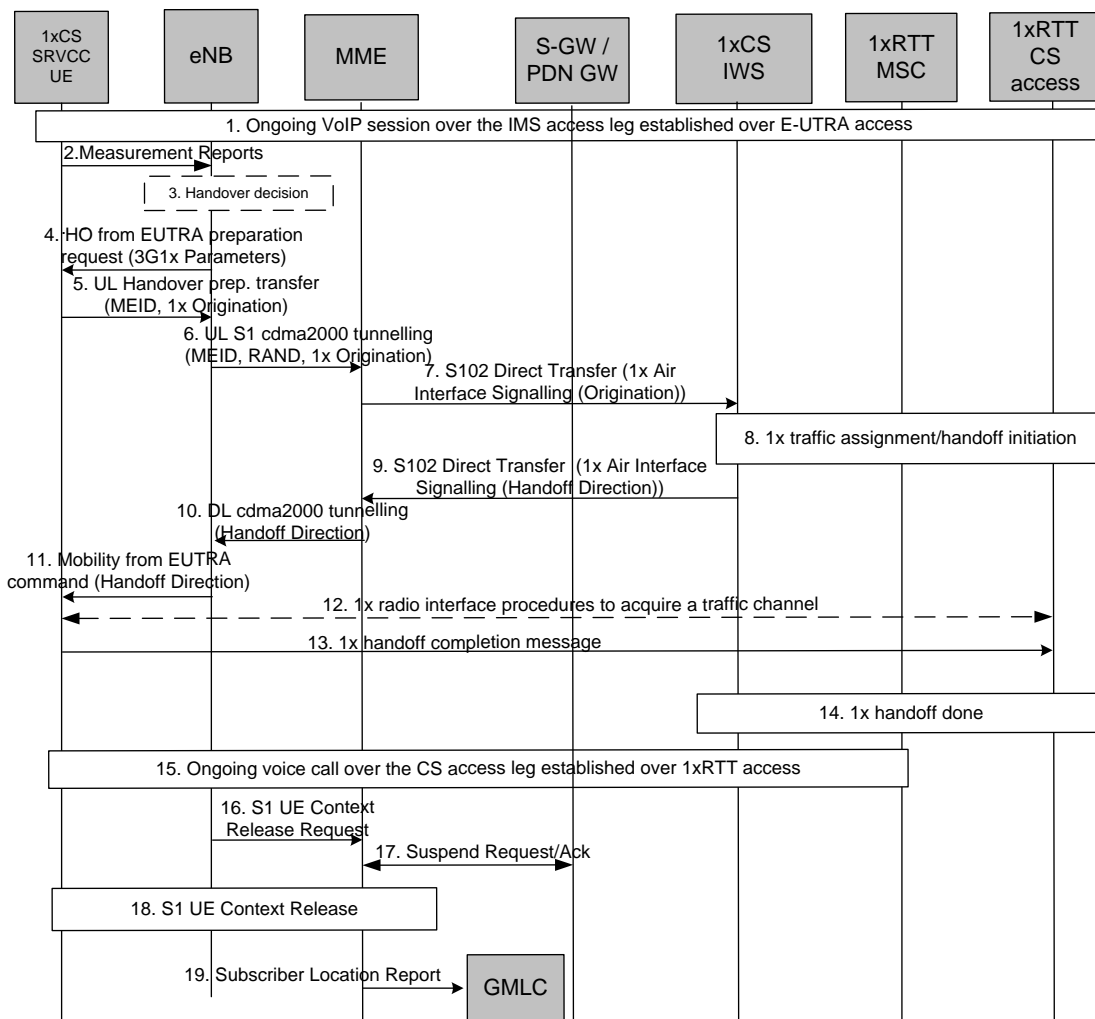

Figure 6.1.3-1: LTE VoIP-to-1x CS voice service continuity

1. Ongoing VoIP session over the IMS access leg established over EPS/E-UTRAN access.
2. 1xCS SRVCC UE sends measurement reports to eNodeB.
3. The E-UTRAN (e.g., based on some trigger, measurement reports) makes a determination to initiate an inter-technology handover to cdma2000 1xRTT.
4. The E-UTRAN signals the UE to perform an inter-technology handover by sending a Handover from EUTRA Preparation Request (3G1x Overhead Parameters, RAND value) message.
5. The UE initiates signalling for establishment of the CS access leg by sending a UL handover preparation Transfer message containing the 1xRTT Origination message. For the case of emergency voice service continuity, the request includes a Request-Type = "emergency handover" and the MEID (e.g. IMEI) is included.
6. The E-UTRAN sends an Uplink S1 cdma2000 Tunnelling (MEID, RAND, 1x Origination, Reference CellID) message to the MME. The eNodeB will also include CDMA2000 HO Required Indication IE to Uplink S1 CDMA2000 Tunnelling message, which indicates to the MME that the handover preparation has started.
7. Upon reception of the Uplink S1 cdma2000 Tunnelling message, the MME selects a 3GPP2 1xCS IWS as specified in clause 5.3.3.1.2 and encapsulates the 1x Origination Message along with the MEID and RAND in a S102 Direct Transfer message (as "1x Air Interface Signalling").
8. The traffic channel resources are established in the 1x RTT system and 3GPP2 1xCS procedures for initiation of Session Transfer are performed as per 3GPP2 X.S0042 [4].

NOTE 1: Step 9 and 3GPP2 1xCS procedures in step 8 are independent of each other.

NOTE 2: For non-emergency session transfers, the "VDN" parameter referred to in 3GPP2 X.S0042 [4] corresponds to the STN-SR parameter defined in TS 23.237 [14].

NOTE 3: The emergency session transfer procedures and procedures for the 1x CS SRVCC UE obtaining the local emergency STN-SR will be specified by 3GPP2.

9. The 3GPP2 1xCS IWS creates a 1x message and encapsulates it in a S102 Direct Transfer message (1x message, Handover indicator). If the 3GPP2 access was able to allocate resources successfully, the 1x message is a 1x Handover Direction message and the handover indicator indicates successful resource allocation. Otherwise, the handover indicator indicates to the MME that handover preparation failed and the embedded 1x message indicates the failure to the UE.
10. The MME sends the 1x message and CDMA2000 HO Status IE in a Downlink S1 cdma2000 Tunnelling message to the E-UTRAN. The CDMA2000 HO Status IE is set according to the handover indicator received over the S102 tunnel.
11. If the CDMA2000 HO Status IE indicates successful handover preparation, the E-UTRAN forwards the 1x Handoff Direction message embedded in a Mobility from EUTRA Command message to the UE. This is perceived by the UE as a Handover Command message. If handover preparation failed, DL Information transfer message will be sent instead, with the embedded 1xRTT message that indicates the failure to the UE.
12. Once the UE receives the traffic channel information from the cdma2000 1xRTT system, the UE retunes to the 1xRTT radio access network and performs traffic channel acquisition with the 1xRTT CS access (e.g., 1xRTT BSS).
13. The UE sends a 1xRTT handoff completion message to the 1xRTT CS access (e.g., 1xRTT BSS).
14. The 1xRTT CS Access sends message to 1xRTT MSC to indicate of handoff done. The resources between 1x CS IWS and 1xRTT MSC may be released at this step.
15. Ongoing voice call over the CS access leg established over 1xRTT access. The E-UTRAN/EPS context may be released based on the normal E-UTRAN/EPS procedure.
16. The eNodeB sends an S1 UE Context Release Request (Cause) message to the MME. Cause indicates the S1 release procedure is caused by handover from E-UTRAN to 1xRTT.
17. The MME deactivates GBR bearers towards S-GW and P-GW(s) by initiating MME-initiated Dedicated Bearer Deactivation procedure as specified in TS 23.401 [2]. The MME starts preservation and suspension of non-GBR bearers by sending Suspend Notification message towards S-GW. The S-GW releases S1-U bearers for the UE and sends Suspend Notification message to the P-GW(s). The MME stores in the UE context that the UE is in suspended status. All the preserved non-GBR bearers are marked as suspended status in the S-GW and P-GW. The P-GW should discard packets if received for the suspended UE.
18. S1 UE Context in the eNodeB is released as specified in TS 23.401 [2].
19. For an emergency services session after handover is complete, if the control plane location solution is used on the source side, the source MME shall send a Subscriber Location Report carrying an indication of the 1xRTT MSC (e.g. reference cell ID) to the GMLC associated with the source side as defined in TS 23.271 [29] to support location continuity. This enables location continuity for the 1xRTT side. Alternatively, if the control plane solution is not used on the source side, location continuity procedures shall be instigated on the 1xRTT side.

NOTE 4: Location continuity on the 1xRTT side will be specified by 3GPP2.

6.2 E-UTRAN and 3GPP GERAN/UTRAN SRVCC

6.2.1 E-UTRAN Attach procedure for SRVCC

E-UTRAN attach procedure for 3GPP SRVCC UE is performed as defined in TS 23.401 [2] with the following additions:

- SRVCC UE includes the SRVCC capability indication as part of the "MS Network Capability" in the Attach Request message and in Tracking Area Updates. MME stores this information for SRVCC operation. The procedures are as specified in TS 23.401 [2].

NOTE 1: If the service configuration on the UE is changed (e.g. the user changes between an IMS speech service supported by the home operator and a PS speech service incompatible with SRVCC), the UE can change its SRVCC capability indication as part of the "MS Network Capability" in a Tracking Area Update message.

- SRVCC UE includes the GERAN MS Classmark 3 (if GERAN access is supported), MS Classmark 2 (if GERAN or UTRAN access or both are supported) and Supported Codecs IE (if GERAN or UTRAN access or both are supported) in the Attach Request message and in the non-periodic Tracking Area Update messages.

NOTE 2: MS Classmark 2, MS Classmark 3, STN-SR, C-MSISDN, ICS Indicator and the Supported Codec IE are not sent from the source MME to the target MME/SGSN at inter CN-node idle mode mobility.

- HSS includes SRVCC STN-SR and C MSISDN as part of the subscription data sent to the MME. If the SRVCC STN-SR is present, it indicates the UE is SRVCC subscribed. If a roaming subscriber is determined by the HPLMN not allowed to have SRVCC in the VPLMN then HSS does not include SRVCC STN-SR and C-MSISDN as part of the subscription data sent to the MME.
- MME includes a "SRVCC operation possible" indication in the S1 AP Initial Context Setup Request, meaning that both UE and MME are SRVCC-capable.

E-UTRAN emergency attach procedure for 3GPP SRVCC UE is performed as defined in TS 23.401 [2] and above with the following clarifications:

- SRVCC UE shall include the SRVCC capability indication as part of the "MS Network Capability" in the Emergency Attach Request message, and maintained during Tracking Area Updates. MME stores this information for SRVCC operation. The procedures are as specified in TS 23.401 [2].

6.2.1A Service Request procedures for SRVCC

Service Request procedures for 3GPP SRVCC UE are performed as defined in TS 23.401 [2] with the following additions:

- MME includes a "SRVCC operation possible" indication in the S1 AP Initial Context Setup Request, meaning that both UE and MME are SRVCC-capable.

6.2.1B PS Handover procedures for SRVCC

Intra-E-UTRAN S1-based handover and E-UTRAN to UTRAN (HSPA) Iu mode Inter RAT handover procedures for 3GPP SRVCC UE are performed as defined in TS 23.401 [2] with the following additions:

- MS Classmark 2, MS Classmark 3, STN-SR, C-MSISDN, ICS Indicator and the Supported Codec IE shall be sent from the source MME to the target MME/SGSN if available.
- The target MME includes a "SRVCC operation possible" indication in the S1-AP Handover Request message, meaning that both UE and the target MME are SRVCC-capable.
- The target SGSN includes a "SRVCC operation possible" indication in the RANAP Common ID message, meaning that both UE and the target SGSN are SRVCC-capable.

For X2-based handover, the source eNodeB includes a "SRVCC operation possible" indication in the X2-AP Handover Request message to the target eNodeB as specified in TS 36.423 [32].

6.2.2 Call flows for SRVCC from E-UTRAN

NOTE 1: If the MSC Server enhanced for SRVCC controls the target BSS/RNS, the steps depicted with dot-dashed arrows representing the MSC-MSC handover procedure defined in TS 23.009 [18] are not executed and the functions of the MSC Server enhanced for SRVCC are merged with those of the target MSC.

NOTE 2: For the sake of brevity the call flow descriptions use "MSC Server" instead of "MSC Server enhanced for SRVCC".

NOTE 3: The target MSC need not be enhanced for SRVCC.

6.2.2.1 SRVCC from E-UTRAN to GERAN without DTM support

Depicted in figure 6.2.2.1-1 is a call flow for SRVCC from E-UTRAN to GERAN without DTM support. The flow requires that eNB can determine that the target is GERAN without DTM support or that the UE is without DTM support.

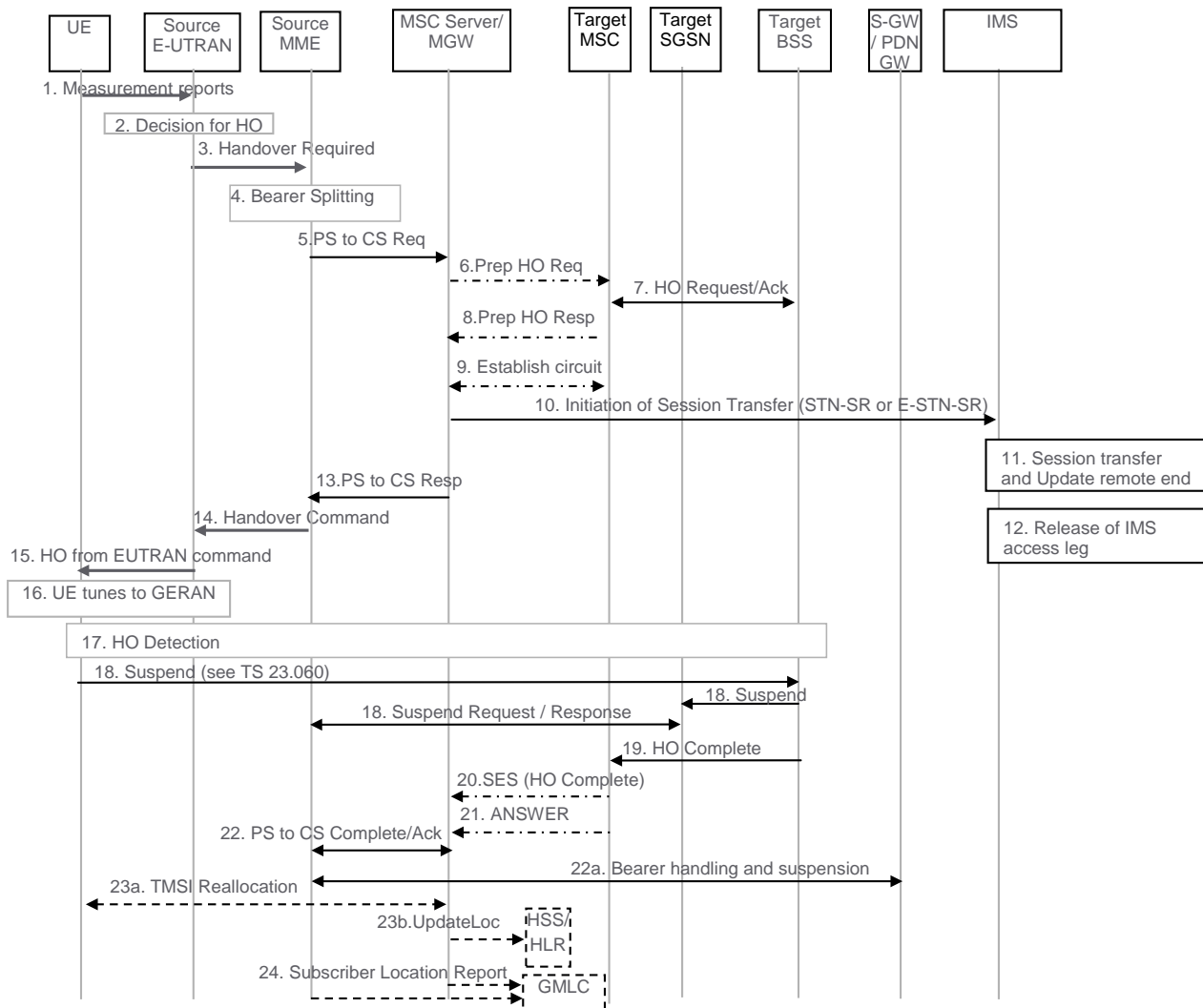

Figure 6.2.2.1-1: SRVCC from E-UTRAN to GERAN without DTM support

1. UE sends measurement reports to E-UTRAN.
2. Based on UE measurement reports the source E-UTRAN decides to trigger an SRVCC handover to GERAN.
3. Source E-UTRAN sends Handover Required (Target ID, generic Source to Target Transparent Container, SRVCC HO Indication) message to the source MME. The E-UTRAN places the "old BSS to new BSS information IE" for the CS domain in the generic Source to Target Transparent Container. The SRVCC HO indication indicates to the MME that target is only CS capable, hence this is a SRVCC handover operation only towards the CS domain. The message includes an indication that the UE is not available for the PS service in the target cell.
4. Based on the QCI associated with the voice bearer (QCI 1) and the SRVCC HO indication, the source MME splits the voice bearer from the non voice bearers and initiates the PS-CS handover procedure for the voice bearer only towards MSC Server.

5. The MME sends a SRVCC PS to CS Request (IMSI, Target ID, STN-SR, C-MSISDN, generic Source to Target Transparent Container, MM Context, Emergency Indication) message to the MSC Server. The Emergency Indication and the equipment identifier are included if the ongoing session is emergency session. Authenticated IMSI and C-MSISDN shall also be included, if available. The MME received STN-SR and C-MSISDN from the HSS as part of the subscription profile downloaded during the E-UTRAN attach procedure. The MM Context contains security related information. CS security key is derived by the MME from the E-UTRAN/EPS domain key as defined in TS 33.401 [22]. The CS Security key is sent in the MM Context.
6. The MSC Server interworks the PS-CS handover request with a CS inter-MSC handover request by sending a Prepare Handover Request message to the target MSC. The MSC Server assigns a default SAI as Source ID on the interface to the target BSS and uses BSSMAP encapsulated for the Prepare Handover Request.

NOTE 1: The value of the default SAI is configured in the MSC and allows a release 8 and later BSC to identify that the source for the SRVCC Handover is E-UTRAN. To ensure correct statistics in the target BSS the default SAI should be different from the SAIs used in UTRAN.

7. Target MSC performs resource allocation with the target BSS by exchanging Handover Request/ Acknowledge messages.
8. Target MSC sends a Prepare Handover Response message to the MSC Server.
9. Establishment of circuit connection between the target MSC and the MGW associated with the MSC Server e.g. using ISUP IAM and ACM messages.
10. For non-emergency session, the MSC Server initiates the Session Transfer by using the STN-SR e.g. by sending an ISUP IAM (STN-SR) message towards the IMS. For emergency session, the MSC Server initiates the Session Transfer by using the locally configured E-STN-SR and by including the equipment identifier. Standard IMS Service Continuity or Emergency IMS Service Continuity procedures are applied for execution of the Session Transfer, see TS 23.237 [14].

NOTE 2: This step can be started after step 8.

NOTE 3: If the MSC Server is using an ISUP interface, then the initiation of the session transfer for non-emergency session may fail if the subscriber profile including CAMEL triggers is not available prior handover (see clause 7.3.2.1.3 in TS 23.292 [13]).

11. During the execution of the Session Transfer procedure the remote end is updated with the SDP of the CS access leg. The downlink flow of VoIP packets is switched towards the CS access leg at this point.
12. Source IMS access leg is released as per TS 23.237 [14].

NOTE 4: Steps 11 and 12 are independent of step 13.

13. MSC Server sends a SRVCC PS to CS Response (Target to Source Transparent Container) message to the source MME.
14. Source MME sends a Handover Command (Target to Source Transparent Container) message to the source E-UTRAN. The message includes information about the voice component only.
15. Source E-UTRAN sends a Handover from E-UTRAN Command message to the UE.
16. UE tunes to GERAN.
17. Handover Detection at the target BSS occurs. The UE sends a Handover Complete message via the target BSS to the target MSC. If the target MSC is not the MSC Server, then the Target MSC sends an SES (Handover Complete) message to the MSC Server.
18. The UE starts the Suspend procedure specified in TS 23.060 [10], clause 16.2.1.1.2. The TLLI and RAI pair are derived from the GUTI as described in TS 23.003 [27]. This triggers the Target SGSN to send a Suspend Notification message to the Source MME. The MME returns a Suspend Acknowledge to the Target SGSN.

NOTE 5: The MME might not be able to derive the GUTI from the received P-TMSI and RAI pair and therefore it might not be able to identify which UE context is associated with the Suspend Notification message. Also in this case the bearers are deactivated and/or suspended as in step 22a.

19. Target BSS sends a Handover Complete message to the target MSC.

20. Target MSC sends an SES (Handover Complete) message to the MSC Server. The speech circuit is through connected in the MSC Server/MGW according to TS 23.009 [18].
21. Completion of the establishment procedure with ISUP Answer message to the MSC Server according to TS 23.009 [18].
22. MSC Server sends a SRVCC PS to CS Complete Notification message to the source MME, informing it that the UE has arrived on the target side. Source MME acknowledges the information by sending a SRVCC PS to CS Complete Acknowledge message to the MSC Server.
- 22a. The MME deactivates bearers used for voice and other GBR bearers. All GBR bearers are deactivated towards S-GW and P-GW by initiating MME-initiated Dedicated Bearer Deactivation procedure as specified in TS 23.401 [2]. The MME does not send deactivation request toward the eNodeB on receiving PS-to-CS Complete Notification in step 22. PS-to-CS handover indicator is notified to P-GW for voice bearer during the bearer deactivation procedure. For GTP-based S5/S8, the S-GW requests the P-GW to delete all GBR bearer contexts by sending a Delete Bearer Command message. If dynamic PCC is deployed, the P-GW may interact with PCRF as defined in TS 23.203 [31]. For PMIP-based S5/S8, S-GW interacts with the PCRF which in turn updates PCC rules for GBR traffic in the P-GW.

The MME starts preservation and suspension of non-GBR bearers by sending Suspend Notification message towards S-GW. For these non-GBR bearers, the S-GW releases S1-U bearers for the UE and sends Suspend Notification message to the P-GW(s). The MME stores in the UE context that UE is in suspended status. All the preserved non-GBR bearers are marked as suspended status in the S-GW and P-GW. The P-GW should discard packets if received for the suspended UE.

- 23a. If the HLR is to be updated, i.e. if the IMSI is authenticated but unknown in the VLR, the MSC Server performs a TMSI reallocation towards the UE using its own non-broadcast LAI and, if the MSC Server and other MSC/VLRs serve the same (target) LAI, with its own Network Resource Identifier (NRI).

NOTE 5: The TMSI reallocation is performed by the MSC Server towards the UE via target MSC.

- 23b. If the MSC Server performed a TMSI reallocation in step 23a, and if this TMSI reallocation was completed successfully, the MSC Server performs a MAP Update Location to the HSS/HLR.

NOTE 6: This Update Location is not initiated by the UE.

24. For an emergency services session after handover is complete, the source MME or the MSC Server may send a Subscriber Location Report carrying the identity of the MSC Server to a GMLC associated with the source or target side, respectively, as defined in TS 23.271 [29] to support location continuity.

NOTE 7: Any configuration of the choice between a source MME versus MSC Server update to a GMLC needs to ensure that a single update occurs from one of these entities when the control plane location solution is used on the source and/or target sides.

After the CS voice call is terminated and if the UE is still in GERAN (or for any other reason specified in TS 24.008), then the UE shall resume PS services as specified in TS 23.060 [10]. A Gn SGSN will follow TS 23.060 [10] to resume the PDP Context(s). An S4 SGSN will follow TS 23.060 [10] to resume the bearers, and will in addition inform S-GW and P-GW(s) to resume the suspended bearers. If the UE has returned to E-UTRAN after the CS voice call was terminated, then the UE shall resume PS service by sending TAU to MME. The MME will in addition inform S-GW and P-GW(s) to resume the suspended bearers. Resuming the suspended bearers in the S-GW and in the P-GW should be done by implicit resume using the Modify Bearer request message if it is triggered by the procedure in operation, e.g. RAU, TAU or Service Request. The S-GW is aware of the suspend state of the bearers and will forward the Modify Bearer request to the P-GW. Explicit resume using the Resume Notification message should be used in cases when Modify Bearer Request is not triggered by the procedure in operation.

6.2.2.1A SRVCC from E-UTRAN to GERAN with DTM but without DTM HO support and from E-UTRAN to UTRAN without PS HO

The call flow for this scenario is similar to the call flow depicted in figure 6.2.2.1-1, with the exceptions that the Suspend procedure (step 18 and step 22a in figure 6.2.2.1-1) is not performed and that the MME only deactivates bearers used for voice (step 22a in figure 6.2.2.1-1) and sets the PS-to-CS handover indicator. The scenario requires that eNB can determine that the target is either GERAN with DTM but without DTM HO support and that the UE is supporting DTM or that the target is UTRAN (HSPA) without PS HO support. The message in step 3 in figure 6.2.2.1-1 includes an indication to the MME that the UE is available for PS service in the target cell. Furthermore, if the target is

GERAN, the E-UTRAN places in the generic Source to Target Transparent Container the "old BSS to new BSS information IE", while if the target is UTRAN, the generic Source to Target Transparent container is encoded according to the Source RNC to Target RNC Transparent Container IE definition. At the end of the procedure described in figure 6.2.2.1-1, the remaining PS resources are re-established when the UE performs the Routeing Area update procedure. Triggers for performing Routeing Area update procedure are described in TS 23.060 [10]. The target SGSN may deactivate the PDP contexts that cannot be established as described in TS 23.060 [10].

6.2.2.2 SRVCC from E-UTRAN to UTRAN with PS HO or GERAN with DTM HO support

Depicted in figure 6.2.2.2-1 is a call flow for SRVCC from E-UTRAN to UTRAN or GERAN with DTM HO support, including the handling of the non-voice component. The flow requires that eNB can determine that either the target is UTRAN with PS HO or the target is GERAN with DTM support and the UE is supporting DTM.

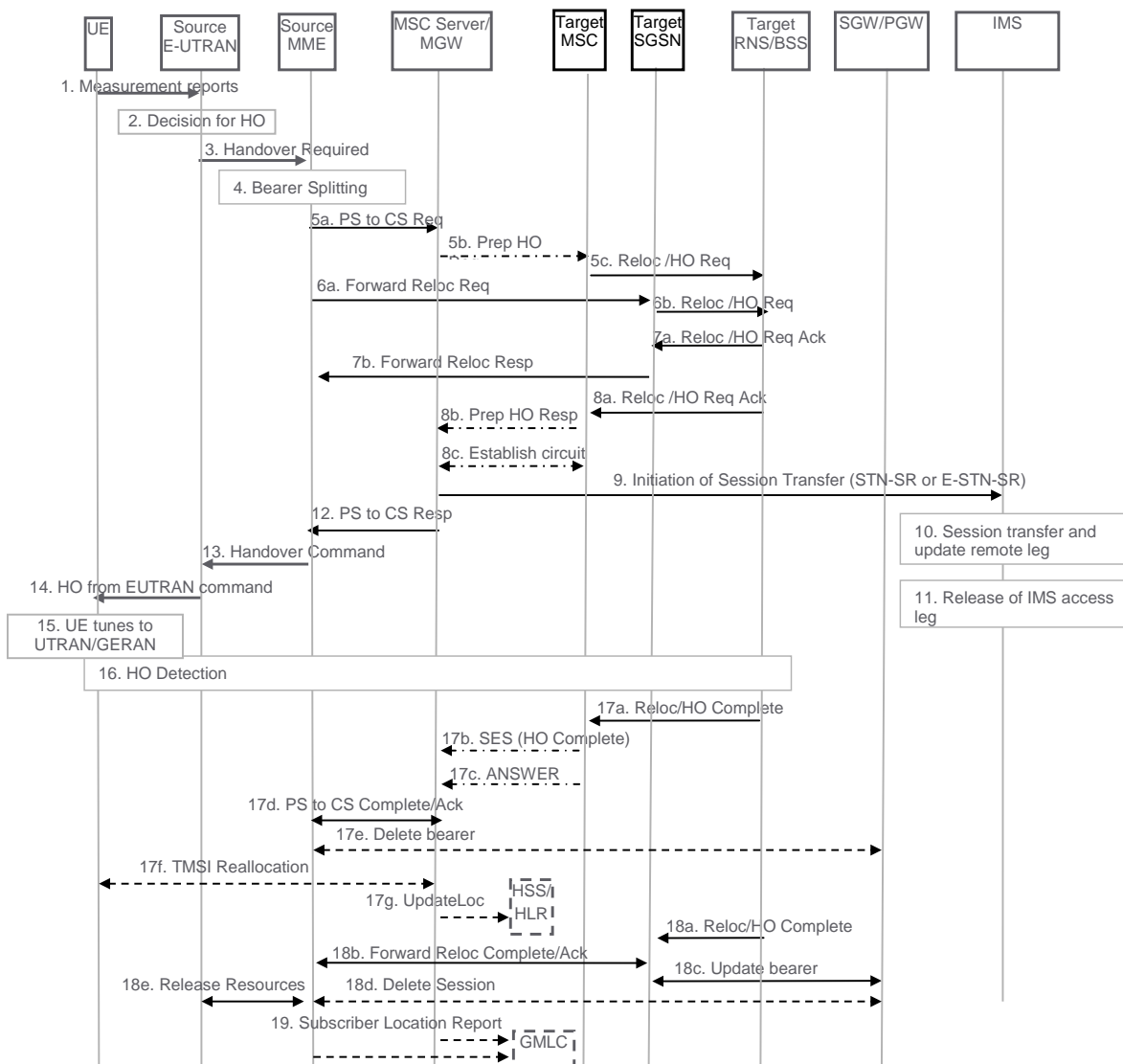

Figure 6.2.2.2-1: SRVCC from E-UTRAN to UTRAN with PS HO or GERAN with DTM HO support

1. UE sends measurement reports to E-UTRAN.
2. Based on UE measurement reports the source E-UTRAN decides to trigger an SRVCC handover to UTRAN/GERAN.
3. If target is UTRAN, the source E-UTRAN sends a Handover Required (Target ID, generic Source to Target Transparent Container, SRVCC HO indication) message to the source MME. SRVCC HO indication indicates to MME that this is for CS+PS HO.

NOTE 1: When the source E-UTRAN indicates using SRVCC HO Indication that target is both CS and PS capable and this is a CS+PS HO request, the source MME sends the single received transparent container to both the target CS domain and the target PS domain.

If target is GERAN, the source E-UTRAN sends a Handover Required (Target ID, generic Source to Target Transparent Container, additional Source to Target Transparent Container, SRVCC HO Indication) message to the source MME. The E-UTRAN places the "old BSS to new BSS information IE" for the CS domain in the additional Source to Target Transparent Container. The differentiation between CS and PS containers is described in TS 36.413 [30]. In this case, the MME identifies from SRVCC HO Indication that this is a request for a CS+PS handover.

4. Based on the QCI associated with the voice bearer (QCI 1) and the SRVCC HO Indication, the source MME splits the voice bearer from all other PS bearers and initiates their relocation towards MSC Server and SGSN, respectively.
- 5a) Source MME initiates the PS-CS handover procedure for the voice bearer by sending a SRVCC PS to CS Request (IMSI, Target ID, STN-SR, C-MSISDN, Source to Target Transparent Container, MM Context, Emergency Indication) message to the MSC Server. The Emergency Indication and the equipment identifier are included if the ongoing session is emergency session. Authenticated IMSI and C-MSISDN shall also be included if available. The message includes information relevant to the CS domain only. MME received STN-SR and C-MSISDN from the HSS as part of the subscription profile downloaded during the E-UTRAN attach procedure. MM Context contains security related information. CS security key is derived by the MME from the E-UTRAN/EPS domain key as defined in TS 33.401 [22]. The CS Security key is sent in the MM Context.
- 5b) MSC Server interworks the PS-CS handover request with a CS inter-MSC handover request by sending a Prepare Handover Request message to the target MSC. If the target system is GERAN, the MSC Server assigns a default SAI as Source ID on the interface to the target BSS and uses BSSMAP encapsulated for the Prepare Handover Request. If the target system is UTRAN, the MSC Server uses RANAP encapsulated for the Prepare Handover Request.

NOTE 2: The value of the default SAI is configured in the MSC and allows a release 8 and later BSC to identify that the source for the SRVCC Handover is E-UTRAN. To ensure correct statistics in the target BSS the default SAI should be different from the SAIs used in UTRAN.

- 5c) Target MSC requests resource allocation for the CS relocation by sending the Relocation Request/Handover Request message to the target RNS/BSS. If the target RAT is UTRAN, Relocation Request/Handover Request message contains the generic Source to Target Transparent Container. If the target RAT is GERAN, Relocation Request/Handover Request message contains the additional Source to Target Transparent Container.
6. In parallel to the previous step the source MME initiates relocation of the PS bearers. The following steps are performed (for details see TS 23.401 [2] clauses 5.5.2.1 and 5.5.2.3):
 - a) Source MME sends a Forward Relocation Request (generic Source to Target Transparent Container, MM Context, PDN Connections IE) message to the target SGSN. If the target SGSN uses S4 based interaction with S-GW and P-GW, the PDN Connections IE includes bearer information for all bearers except the voice bearer. The handling of security keys for PS handover of the remaining non-voice PS bearers is specified in TS 33.401 [22].

NOTE 3: If the target SGSN uses Gn/Gp based interaction with GGSN the Forward Relocation Request will contain PDP Contexts, instead of PDN Connections IE, including bearer information for all bearers except the voice bearer.

- b) Target SGSN requests resource allocation for the PS relocation by sending the Relocation Request/Handover Request (Source to Target Transparent Container) message to the target RNS/BSS.
7. After the target RNS/BSS receives both the CS relocation/handover request with the PS relocation/handover request, it assigns the appropriate CS and PS resources. The following steps are performed:
 - a) Target RNS/BSS acknowledges the prepared PS relocation/handover by sending the Relocation Request Acknowledge/Handover Request Acknowledge (Target to Source Transparent Container) message to the target SGSN.
 - b) Target SGSN sends a Forward Relocation Response (Target to Source Transparent Container) message to the source MME.

8. In parallel to the previous step the following steps are performed:
- Target RNS/BSS acknowledges the prepared CS relocation/handover by sending the Relocation Request Acknowledge/Handover Request Acknowledge (Target to Source Transparent Container) message to the target MSC.
 - Target MSC sends a Prepare Handover Response (Target to Source Transparent Container) message to the MSC Server.
 - Establishment of circuit connection between the target MSC and the MGW associated with the MSC Server e.g. using ISUP IAM and ACM messages.

NOTE 4: The Target to Source Transparent Container sent to the target SGSN is step 7a and the Target to Source Transparent Container sent to the target MSC in step 8a, include the same allocation of CS and PS resources (e.g. the target BSS includes the same DTM Handover Command in both containers).

9. For non-emergency session, the MSC Server initiates the Session Transfer by using the STN-SR e.g. by sending an ISUP IAM (STN-SR) message towards the IMS. For emergency session, the MSC Server initiates the Session Transfer by using the locally configured E-STN-SR and by including the equipment identifier. Standard IMS Service Continuity or Emergency IMS Service Continuity procedures are applied for execution of the Session Transfer, TS 23.237 [14].

NOTE 5: This step can be started after step 8b.

NOTE 6: If the MSC Server is using an ISUP interface, then the initiation of the session transfer for non-emergency sessions may fail if the subscriber profile including CAMEL triggers is not available prior handover (see clause 7.3.2.1.3 of TS 23.292 [13]).

10. During the execution of the Session Transfer procedure the remote end is updated with the SDP of the CS access leg according to TS 23.237 [14]. The downlink flow of VoIP packets is switched towards the CS access leg at this point.

11. The source IMS access leg is released according to TS 23.237 [14].

NOTE 7: Steps 10 and 11 are independent of step 12.

12. The MSC Server sends a SRVCC PS to CS Response (Target to Source Transparent Container) message to the source MME.

13. Source MME synchronises the two prepared relocations and sends a Handover Command (Target to Source Transparent Container) message to the source E-UTRAN.

NOTE 8: When the target cell is GERAN, the MME may receive different Target to Source Transparent Containers from the MSC Server and from the SGSN, i.e. a "New BSS to Old BSS Information" (see TS 48.008 [23]) may be received from the MSC Server and a "Target BSS to Source BSS Transparent Container" (see TS 48.018 [24]) may be received from the SGSN.

14. E-UTRAN sends a Handover from E-UTRAN Command message to the UE.

15. UE tunes to the target UTRAN/GERAN cell.

16. Handover Detection at the target RNS/BSS occurs. The UE sends a Handover Complete message via the target RNS/BSS to the target MSC. If the target MSC is not the MSC Server, then the Target MSC sends an SES (Handover Complete) message to the MSC Server. At this stage, the UE re-establishes the connection with the network and can send/receive voice data.

17. The CS relocation/handover is complete. The following steps are performed:

- Target RNS/BSS sends Relocation Complete/Handover Complete message to the target MSC.
- Target MSC sends an SES (Handover Complete) message to the MSC Server. The speech circuit is through connected in the MSC Server/MGW according to TS 23.009 [18].
- Completion of the establishment procedure with ISUP Answer message to the MSC Server according to TS 23.009 [18].

- d) MSC Server sends a SRVCC PS to CS Complete Notification message to the source MME. Source MME acknowledges the information by sending a SRVCC PS to CS Complete Acknowledge message to the MSC Server.
- e) The source MME deactivates the voice bearer towards S-GW/P-GW and sets the PS-to-CS handover indicator to Delete Bearer Command message. This triggers MME-initiated Dedicated Bearer Deactivation procedure as specified in TS 23.401 [2]. The MME does not send deactivation request toward the eNodeB on receiving PS-to-CS Complete Notification in step 17d. If dynamic PCC is deployed, the PGW may interact with PCRF as defined in TS 23.203 [31].
- f) If the HLR is to be updated, i.e. if the IMSI is authenticated but unknown in the VLR, the MSC Server performs a TMSI reallocation towards the UE using its own non-broadcast LAI and, if the MSC Server and other MSC/VLRs serve the same (target) LAI, with its own Network Resource Identifier (NRI).

NOTE 9: The TMSI reallocation is performed by the MSC Server towards the UE via target MSC.

- g) If the MSC Server performed a TMSI reallocation in step 17f, and if this TMSI reallocation was completed successfully, the MSC Server performs a MAP Update Location to the HSS/HLR.

NOTE 10: This Update Location is not initiated by the UE.

18. In parallel to the previous step, the PS relocation/handover is completed. The following steps are performed:

- a) Target RNS/BSS sends Relocation Complete/Handover Complete message to target SGSN.
- b) Target SGSN sends a Forward Relocation Complete message to the source MME. After having completed step 17e, the source MME acknowledges the information by sending a Forward Relocation Complete Acknowledge message to the target SGSN.
- c) Target SGSN updates the bearer with S-GW/P-GW/GGSN as specified in TS 23.401 [2].
- d) The MME sends Delete Session Request to the SGW as defined in TS 23.401 [2].
- e) The source MME sends a Release Resources message to the Source eNodeB as defined in TS 23.401 [2]. The Source eNodeB releases its resources related to the UE.

NOTE 11: Routing Area Update procedures by the UE are done in accordance with TS 23.401 [2].

19. For an emergency services session after handover is complete, the source MME or the MSC Server may send a Subscriber Location Report carrying the identity of the MSC Server to a GMLC associated with the source or target side, respectively, as defined in TS 23.271 [29] to support location continuity.

NOTE 12: Any configuration of the choice between a source MME versus MSC Server update to a GMLC needs to ensure that a single update occurs from one of these entities when the control plane location solution is used on the source and/or target sides.

In case the MME determines that only the relocation of the voice bearer but not the relocation of one or more PS bearers succeeds, then the MME proceeds with step 13 after receiving SRVCC PS to CS Response from the MSC Server in step 12 and both UE and MME continue the procedure as described in clause 6.2.2.1A.

6.3 UTRAN (HSPA) and 3GPP GERAN/UTRAN SRVCC

6.3.1 GPRS Attach procedure for SRVCC

GPRS attach procedure for 3GPP SRVCC UE is performed as defined in TS 23.060 [10] with the following additions:

- SRVCC UE includes the SRVCC capability indication as part of the "MS Network Capability" in the Attach Request message and in Routing Area Updates. SGSN stores this information for SRVCC operation.

NOTE 1: If the service configuration on the UE is changed (e.g. the user changes between an IMS speech service supported by the home operator and a PS speech service incompatible with SRVCC), the UE can change its SRVCC capability indication as part of the "MS Network Capability" in a Routing Area Update message.

- SRVCC UE includes the GERAN MS Classmark 3 (if GERAN access is supported), MS Classmark 2 and Supported Codecs IE in the Attach Request message and in the non-periodic Routing Area Update messages.

NOTE 2: MS Classmark 2, MS Classmark 3, STN-SR, C-MSISDN, ICS Indicator and the Supported Codec IE are not sent from the source SGSN to the target MME/SGSN at inter CN-node idle mode mobility.

- HSS includes SRVCC STN-SR and C MSISDN as part of the subscription data sent to the SGSN. If the SRVCC STN-SR is present, it indicates the UE is SRVCC subscribed. If a roaming subscriber is determined by the HPLMN not allowed to have SRVCC in the VPLMN then HSS does not include STN-SR and C-MSISDN as part of the subscription data sent to the SGSN.
- SGSN includes a "SRVCC operation possible" indication in the RANAP Common ID message, meaning that both UE and SGSN are SRVCC-capable.

GPRS emergency attach procedure for 3GPP SRVCC UE is performed as defined in TS 23.060 [10] and above with the following clarifications:

- SRVCC UE shall include the SRVCC capability indication as part of the "MS Network Capability" in the Emergency Attach Request message and maintained during Routing Area Updates. SGSN stores this information for SRVCC operation.

6.3.1A Service Request procedures for SRVCC

Service Request procedures for 3GPP SRVCC UE are performed as defined in TS 23.060 [10] with the following additions:

- SGSN includes a "SRVCC operation possible" indication in the RANAP Common ID message, meaning that both UE and SGSN are SRVCC-capable.

6.3.1B PS Handover procedures for SRVCC

Intra-UTRAN (HSPA) SRNS Relocation procedure for 3GPP SRVCC UE are performed as defined in TS 23.060 [10] and UTRAN (HSPA) Iu mode to E-UTRAN Inter RAT handover are performed as defined in TS 23.401 [2], with the following additions:

- MS Classmark 2, MS Classmark 3, STN-SR, C-MSISDN, ICS Indicator and the Supported Codec IE shall be sent from the source SGSN to the target SGSN/MME if available.
- The target SGSN includes a "SRVCC operation possible" indication in the RANAP Common ID message, meaning that both UE and the target SGSN are SRVCC-capable.
- The target MME includes a "SRVCC operation possible" indication in the S1-AP Handover Request message, meaning that both UE and the target MME are SRVCC-capable.

6.3.2 Call flows for SRVCC from UTRAN (HSPA)

NOTE 1: If the MSC Server enhanced for SRVCC controls the target BSS/RNS, the steps depicted with dot-dashed arrows representing the MSC-MSC handover procedure defined in TS 23.009 [18] are not executed and the functions of the MSC Server enhanced for SRVCC are merged with those of the target MSC.

NOTE 2: For the sake of brevity the call flow descriptions use "MSC Server" instead of "MSC Server enhanced for SRVCC".

NOTE 3: The target MSC need not be enhanced for SRVCC.

6.3.2.1 SRVCC from UTRAN (HSPA) to GERAN without DTM support

Depicted in figure 6.3.2.1-1 is a call flow for SRVCC from HSPA to GERAN without DTM support. The flow requires that NB can determine that the target is GERAN without DTM support or that the UE is without DTM support.

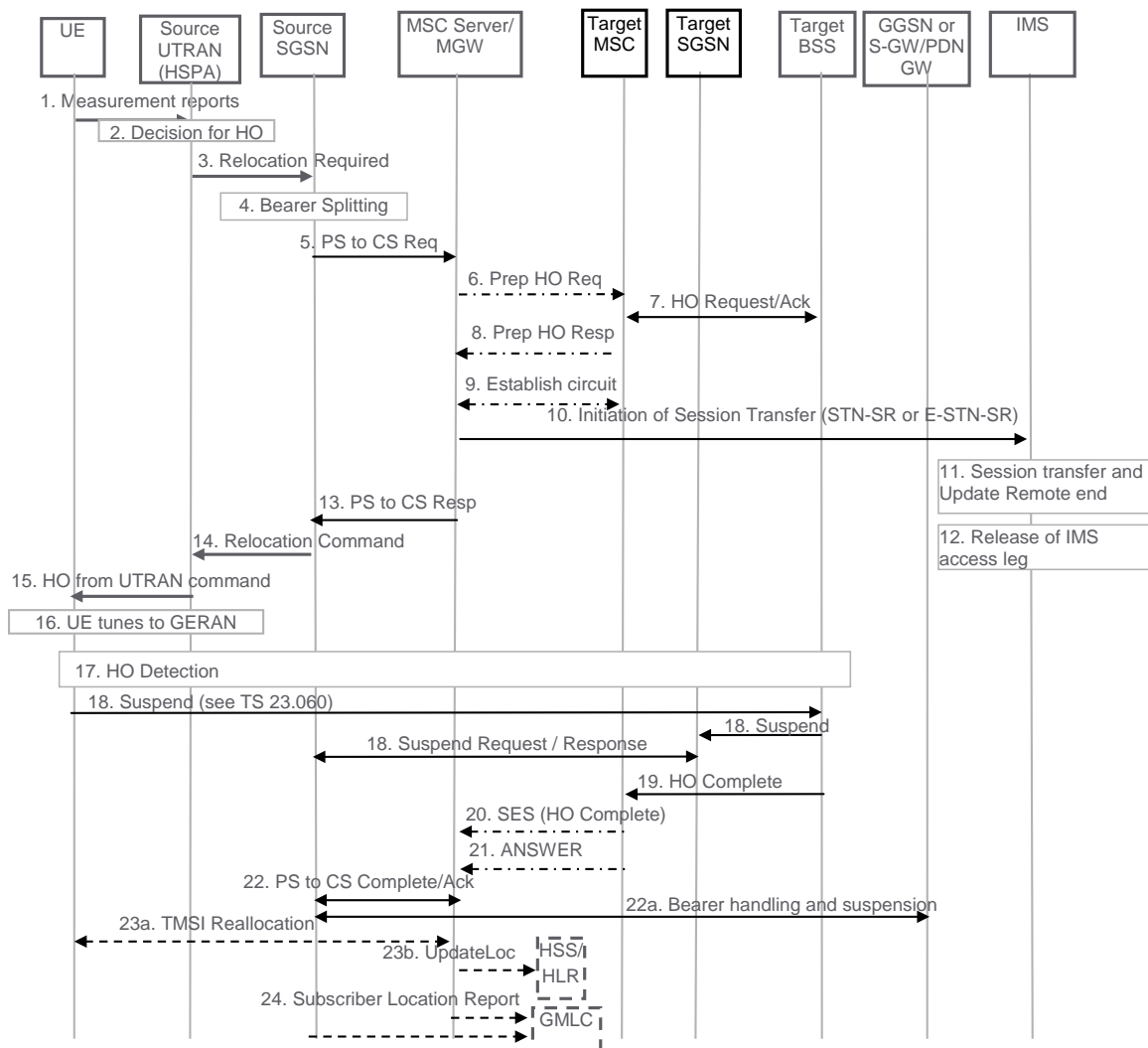

Figure 6.3.2.1-1: SRVCC from UTRAN (HSPA) to GERAN without DTM support

1. UE sends measurement reports to Source UTRAN (HSPA).
2. Based on UE measurement reports the source UTRAN (HSPA) decides to trigger a handover to GERAN.
3. Source UTRAN (HSPA) sends Relocation Required (Target ID, Source to Target Transparent Container, SRVCC Handover Indication) message to the source SGSN. The UTRAN (HSPA) includes the "old BSS to new BSS information IE" for the CS domain. The SRVCC Handover Indication indicates to the SGSN that this is a SRVCC handover operation only towards the CS domain. The message includes an indication that the UE is not available for PS service in the target cell.
4. Based on the Traffic Class associated with conversational and Source Statistic Descriptor = speech, and the SRVCC Handover Indication the source SGSN splits the voice bearer from the non-voice bearers and initiates the PS-CS handover procedure for the voice bearer only towards MSC server.
5. Source SGSN sends a SRVCC PS to CS Request (IMSI, Target ID, STN-SR, C-MSISDN, Source to Target Transparent Container, MM Context, Emergency Indication, Source SAI) message to the MSC Server. The Emergency Indication and the equipment identifier are included if an ongoing session is an emergency session. Authenticated IMSI and C-MSISDN shall also be included if available. SGSN received the STN-SR and C-MSISDN from the HSS as part of the subscription profile downloaded during the UTRAN (HSPA) attach procedure. The MM Context contains security related information. The CS Security key is derived by SGSN from the UTRAN (HSPA)/EPS domain key as defined in TS 33.102 [25]. The Source SAI shall be set to the Serving Area Identifier received from the source RNC.
6. The MSC Server interworks the PS handover request with a CS inter-MSC handover request by sending a Prepare Handover Request message to the target MSC. The MSC Server uses BSSMAP encapsulated for the Prepare Handover Request.

7. Target MSC performs resource allocation with the target BSS by exchanging Handover Request/ Acknowledge messages.
8. Target MSC sends a Prepare Handover Response message to the MSC Server.
9. Establishment of circuit connection between the target MSC and the MGW associated with the MSC Server e.g. using ISUP IAM and ACM messages.
10. For non-emergency session, the MSC Server initiates the Session Transfer by using the STN-SR e.g. by sending an ISUP IAM (STN-SR) message towards the IMS. For emergency session, the MSC Server initiates the Session Transfer by using the locally configured E-STN-SR and by including the equipment identifier. Standard IMS Service Continuity or Emergency IMS Service Continuity procedures are applied for execution of the Session Transfer, see TS 23.237 [14].

NOTE 1: This step can be started after step 8.

NOTE 2: If the MSC Server is using an ISUP interface, then the initiation of the session transfer for non-emergency session may fail if the subscriber profile including CAMEL triggers is not available prior handover (see clause 7.3.2.1.3 of TS 23.292 [13]).

11. During the execution of the Session Transfer procedure the remote end is updated with the SDP of the CS access leg. The downlink flow of VoIP packets is switched towards the CS access leg at this point.

12. Source IMS access leg is released according to TS 23.237 [14].

NOTE 3: Steps 11 and 12 are independent of step 13.

13. MSC Server sends a SRVCC PS to CS Response (Target to Source Transparent Container) message to the source SGSN.

14. Source SGSN sends a Relocation Command (Target to Source Transparent Container) message to the source UTRAN (HSPA). The message includes information about the voice component only.

15. Source UTRAN (HSPA) sends a Handover Command message to the UE.

16. UE tunes to GERAN.

17. Handover Detection at the target BSS occurs. The UE sends a Handover Complete message via the target RNS/BSS to the target MSC.

18. The UE starts the Suspend procedure specified in TS 23.060 [10], clause 16.2.1.1.2. The TLLI and RAI pair are derived from the GUTI as described in TS 23.003 [27]. This triggers the Target SGSN to send a Suspend Request (Gn/Gp SGSN) or Suspend Notification (S4 SGSN) message to the Source SGSN. The Source SGSN returns a Suspend Response or Suspend Acknowledge message to the Target SGSN.

19. Target BSS sends a Handover Complete message to the target MSC.

20. Target MSC sends an SES (Handover Complete) message to the MSC Server. The speech circuit is through connected in the MSC Server/MGW according to TS 23.009 [18].

21. Completion of the establishment procedure with ISUP Answer message to the MSC Server according to TS 23.009 [18].

22. MSC Server sends a SRVCC PS to CS Complete Notification message to the source SGSN, informing it that the UE has arrived on the target side. Source SGSN acknowledges the information by sending a SRVCC PS to CS Complete Acknowledge message to the MSC Server.

22a. After the SGSN received a Suspend Request/Notification in step 18, the SGSN behaves as follows:

If the SGSN uses Gn/Gp based interaction with GGSN, then:

- The SGSN deactivates PDP Contexts used for voice and it suspends PDP Contexts using background or interactive class.
- For a PDP Context using streaming or conversational traffic class not used for voice, the PDP Context is preserved and the maximum bitrate is downgraded to 0 Kbit/s.

If the SGSN uses S4 based interaction with S-GW and P-GW, then:

- The SGSN deactivates bearers used for voice and other GBR bearers towards S-GW and P-GW by initiating MS- and SGSN Initiated Bearer Deactivation procedure as specified in TS 23.060 [10]. PS-to-CS handover indicator is notified to P-GW for voice bearer during the bearer deactivation procedure.
- If dynamic PCC is deployed, the P-GW may interact with PCRF as defined in TS 23.203 [31].
- The SGSN starts preservation and suspension of non-GBR bearers by sending Suspend Notification message towards S-GW. The S-GW releases all RNC related information (address and TEIDs) for the UE if Direct Tunnel is established, and sends Suspend Notification message to the P-GW(s).

The SGSN stores in the UE context that UE is in suspended status. All the preserved non-GBR bearers are marked as suspended status in the S-GW and P-GW. The P-GW should discard packets if received for the suspended UE.

- 23a. If the HLR is to be updated, i.e. if the IMSI is authenticated but unknown in the VLR, the MSC Server performs a TMSI reallocation towards the UE using its own non-broadcast LAI and, if the MSC Server and other MSC/VLRs serve the same (target) LAI, with its own Network Resource Identifier (NRI).

NOTE 4: The TMSI reallocation is performed by the MSC Server towards the UE via target MSC.

- 23b. If the MSC Server performed a TMSI reallocation in step 23a, and if this TMSI reallocation was completed successfully, the MSC Server performs a MAP Update Location to the HSS/HLR.

NOTE 5: This Update Location is not initiated by the UE.

24. For an emergency services session after handover is complete, the source SGSN or the MSC Server may send a Subscriber Location Report carrying the identity of the MSC Server to a GMLC associated with the source or target side, respectively, as defined in TS 23.271 [29] to support location continuity.

NOTE 6: Any configuration of the choice between a source SGSN versus MSC Server update to a GMLC needs to ensure that a single update occurs from one of these entities when the control plane location solution is used on the source and/or target sides.

After the CS voice call is terminated and if the UE is still in GERAN or UTRAN (or for any other reason according to TS 24.008), then the UE shall resume PS services (as specified in TS 23.060 [10]). A Gn/Gp SGSN will follow TS 23.060 [10] to resume the PDP Context(s). An S4 SGSN will also follow TS 23.060 [10] to resume the bearers, and will in addition inform S-GW and P-GW(s) to resume the suspended bearers. Resuming the suspended bearers in the S-GW and in the P-GW should be done by implicit resume using the Modify Bearer request message if it is triggered by the procedure in operation, e.g. RAU, TAU or Service Request. The S-GW is aware of the suspend state of the bearers and will forward the Modify Bearer request to the P-GW. Explicit resume using the Resume Notification message should be used in cases when Modify Bearer Request is not triggered by the procedure in operation.

6.3.2.1A SRVCC from UTRAN (HSPA) to GERAN with DTM but without DTM HO support and from UTRAN (HSPA) to UTRAN without PS HO

The call flow for this scenario is similar to the call flow depicted in figure 6.3.2.1-1, with the exceptions that the Suspend procedure (step 18 and step 22a in figure 6.3.2.1-1) is not performed and that the source SGSN only deactivates bearers used for voice and sets the PS-to-CS handover indicator. The scenario requires that NB can determine that the target is either GERAN with DTM but without DTM HO support and that the UE is supporting DTM or that the target is UTRAN (HSPA) without PS HO support. The message in step 3 in figure 6.3.2.1 1 includes an indication to the SGSN that the UE is available for PS service in the target cell. At the end of the procedure described in figure 6.3.2.1-1, the remaining PS resources are re-established when the UE performs the Routeing Area update procedure. Triggers for performing Routeing Area update procedure are described in TS 23.060 [10]. The target SGSN may deactivate the PDP contexts that cannot be established as described in TS 23.060 [10].

6.3.2.2 SRVCC from UTRAN (HSPA) to UTRAN or GERAN with DTM HO support

Depicted in figure 6.3.2.2-1 is a call flow for SRVCC from UTRAN (HSPA) to UTRAN or GERAN with DTM HO support, including the handling of the non voice component.

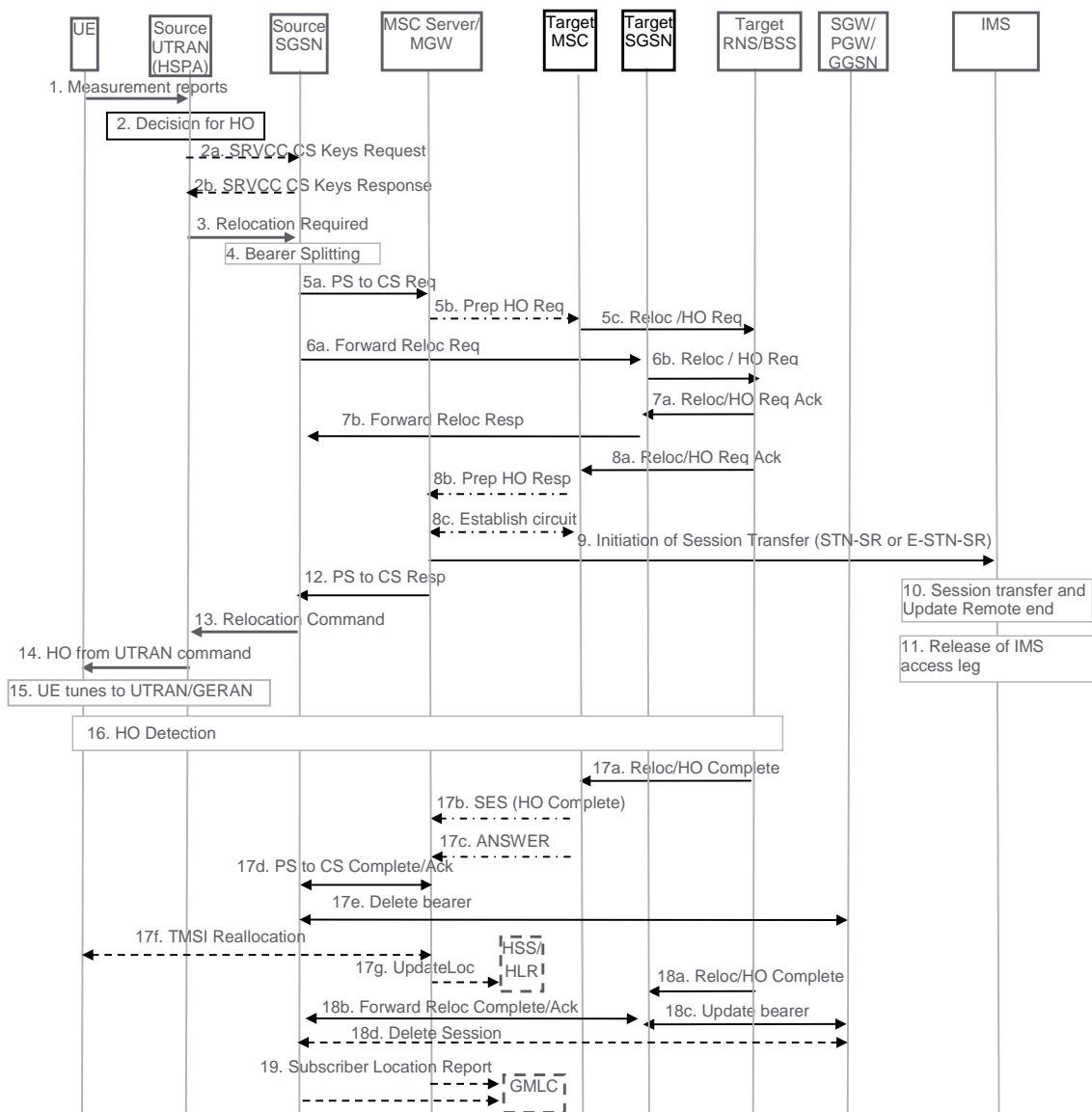

Figure 6.3.2.2-1: SRVCC from UTRAN (HSPA) to UTRAN or GERAN with DTM HO support

1. UE sends measurement reports to Source UTRAN (HSPA).
2. Based on UE measurement reports the source UTRAN (HSPA) decides to trigger a handover to UTRAN/GERAN.
- 2a. In case of SRVCC to UTRAN the RNC shall initiate the SRVCC Preparation procedure by sending an SRVCC CS KEYS REQUEST message to the source SGSN.
- 2b. The SGSN shall respond to the RNC with SRVCC CS KEYS RESPONSE message containing the *Integrity Protection Key IE*, the *Encryption Key IE* and the *SRVCC Information IE*.
3. If target is UTRAN, the source UTRAN (HSPA) sends a Relocation Required (Target ID, Source RNC to Target RNC Transparent Container, SRVCC Handover Indication) message to the source SGSN. UTRAN (HSPA) also indicates to SGSN that this is for CS+PS HO.

NOTE 1: When the source UTRAN (HSPA) indicates that this is a CS+PS HO request, the source SGSN sends the single received transparent container to both the target CS domain and the target PS domain.

If target is GERAN, the source UTRAN (HSPA) sends a Relocation Required (Target ID, Old BSS to New BSS Information IE for the CS domain and Source BSS to Target BSS Transparent Container for the PS Domain, SRVCC Handover Indication) message to the source SGSN. The differentiation between CS and PS containers is described in TS 25.413 [11]. In this case, the SGSN identifies from the SRVCC Handover Indication that this is a request for a CS+PS handover.

4. Based on the Traffic Class associated with conversational and Source Statistic Descriptor = speech, and the SRVCC Handover Indication the Source SGSN splits the voice bearer from all other PS bearers and initiates their relocation towards MSC Server and SGSN, respectively.
- 5a) Source SGSN initiates the PS-CS handover procedure for the voice bearer by sending a SRVCC PS to CS Request (IMSI, Target ID, STN-SR, C-MSISDN, Source to Target Transparent Container, MM Context, Emergency Indication, Source SAI) message to the MSC Server. The Emergency Indication and the equipment identifier are included if the ongoing session is emergency session. Authenticated IMSI and C-MSISDN shall be included if available. The message includes information relevant to the CS domain only. SGSN received STN-SR and C-MSISDN from the HSS as part of the subscription profile downloaded during the UTRAN (HSPA) attach procedure. MM Context contains security related information. The CS Security key is derived by the SGSN from the UTRAN (HSPA)/EPS domain key as defined in TS 33.102 [25]. If the target system is GERAN, the Source SAI shall be set to the Serving Area Identifier received from the source RNC.
- 5b) MSC Server interworks the PS handover request with a CS inter-MSC handover request by sending a Prepare Handover Request message to the target MSC. If the target system is GERAN, MSC Server uses BSSMAP encapsulated for the Prepare Handover Request. If the target system is UTRAN, MSC Server uses RANAP encapsulated for the Prepare Handover Request.
- 5c) Target MSC requests resource allocation for the CS relocation by sending the Relocation Request/Handover Request (Source to Target Transparent Container) message to the target RNS/BSS.
6. In parallel to the previous step the source SGSN initiates relocation of the PS bearers. The following steps are performed (for details see TS 23.060 [10]):
 - a) If the target SGSN uses S4 based interaction with S-GW and P-GW, the source SGSN sends a Forward Relocation Request (Source to Target Transparent Container, MM Context, PDP Context) message to the target SGSN. The PDP Context includes bearer information for all bearers except the voice bearer. The handling of security keys for PS handover of the remaining non-voice PS bearers is specified in TS 33.401 [22].

If the target SGSN uses Gn/Gp based interaction with GGSN, the Source SGSN sends a Forward Relocation Request (Source to Target Transparent Container, MM Context and PDP Context) message to the target SGSN. The PDP Context includes bearer information for all bearers except the voice bearer. The handling of security keys for PS handover of the remaining non-voice PS bearers is specified in TS 33.102 [25].
 - b) Target SGSN requests resource allocation for the PS relocation by sending the Relocation Request/Handover Request (Source to Target Transparent Container) message to the target RNS/BSS.
7. Target RNS/BSS coordinates the CS relocation request with the PS relocation request and assigns resources. The following steps are performed:
 - a) Target RNS/BSS acknowledges the prepared PS relocation by sending the Relocation Request Acknowledge/Handover Request Acknowledge (Target to Source Transparent Container) message to the target SGSN.
 - b) Target SGSN sends a Forward Relocation Response (Target to Source Transparent Container) message to the source SGSN.
8. In parallel to the previous step the following steps are performed:
 - a) Target RNS/BSS acknowledges the prepared CS relocation by sending the Relocation Request Acknowledge/Handover Request Acknowledge (Target to Source Transparent Container) message to the target MSC.
 - b) Target MSC sends a Prepare Handover Response (Target to Source Transparent Container) message to the MSC Server.
 - c) Establishment of circuit connection between the target MSC and the MGW associated with the MSC Server e.g. using ISUP IAM and ACM messages.
9. For non-emergency session, the MSC Server initiates the Session Transfer by using the STN-SR e.g. by sending an ISUP IAM (STN-SR) message towards the IMS. For emergency session, the MSC Server initiates the Session Transfer by using the locally-configured E-STN-SR and by including the equipment identifier. Standard IMS

Service Continuity or Emergency IMS Service Continuity procedures are applied for execution of the Session Transfer, see TS 23.237 [14].

NOTE 2: This step can be started after step 8b.

NOTE 3: If the MSC Server is using an ISUP interface, then the initiation of the session transfer for non-emergency sessions may fail if the subscriber profile including CAMEL triggers is not available prior handover (see clause 7.3.2.1.3 of TS 23.292 [13]).

10. During the execution of the Session Transfer procedure the remote end is updated with the SDP of the CS access leg according to TS 23.237 [14]. The downlink flow of VoIP packets is switched towards the CS access leg at this point.

11. The source IMS access leg is released according to TS 23.237 [14].

NOTE 4: Steps 10 and 11 are independent of step 12.

12. The MSC Server sends a SRVCC PS to CS Response (Target to Source Transparent Container) message to the source SGSN.

13. Source SGSN synchronises the two prepared relocations and sends a Relocation Command (Target to Source Transparent Container) message to the source UTRAN (HSPA). If the target is GERAN, the source RNC shall receive the *SRVCC Information* IE containing the *NONCE* IE.

14. UE tunes to the target UTRAN/GERAN cell.

15. UTRAN (HSPA) sends a Handover Command message to the UE.

16. Handover Detection at the target RNS/BSS. The UE sends a Handover Complete message via the target RNS/BSS to the target MSC.

17. The CS relocation is complete. The following steps are performed:

- a) Target RNS/BSS sends Relocation Complete/Handover Complete message to the target MSC.
- b) Target MSC sends an SES (Handover Complete) message to the MSC Server. The speech circuit is through connected in the MSC Server/MGW according to TS 23.009 [18].
- c) Completion of the establishment procedure with ISUP Answer message to the MSC Server according to TS 23.009 [18].
- d) MSC Server sends a SRVCC PS to CS Complete Notification message to the source SGSN. Source SGSN acknowledges the information by sending a SRVCC PS to CS Complete Acknowledge message to the MSC Server.
- e) The source SGSN deletes the voice bearer towards GGSN/S-GW/P-GW and sets the PS-to-CS handover indicator. If dynamic PCC is deployed, the PGW may interact with PCRF as defined in TS 23.203 [31].
- f) If the HLR is to be updated, i.e. if the IMSI is authenticated but unknown in the VLR, the MSC Server performs a TMSI reallocation towards the UE using its own non-broadcast LAI and, if the MSC Server and other MSC/VLRs serve the same (target) LAI, with its own Network Resource Identifier (NRI).

NOTE 5: The TMSI reallocation is performed by the MSC Server towards the UE via target MSC.

- g) If the MSC Server performed a TMSI reallocation in step 17f, and if this TMSI reallocation was completed successfully, the MSC Server performs a MAP Update Location to the HSS/HLR.

NOTE 6: this Update Location is not initiated by the UE.

18. In parallel to the previous step, the PS relocation is complete. The following steps are performed:

- a) Target RNS/BSS sends Relocation Complete/Handover Complete message to target SGSN.
- b) Target SGSN sends a Forward Relocation Complete message to the source SGSN. After having completed step 17e, source SGSN acknowledges the information by sending a Forward Relocation Complete Acknowledge message to the target SGSN.

- c) Target SGSN updates the bearer with GGSN/S-GW/P-GW.
- d) The Source S4-SGSN sends delete Session Request to the SGW as defined in TS 23.401 [2].

19. For an emergency services session after handover is complete, the source SGSN or the MSC Server may send a Subscriber Location Report carrying the identity of the MSC Server to a GMLC associated with the source or target side, respectively, as defined in TS 23.271 [29] to support location continuity.

NOTE 7: Any configuration of the choice between a source SGSN versus MSC Server update to a GMLC needs to ensure that a single update occurs from one of these entities when the control plane location solution is used on the source and/or target sides.

In case the SGSN determines that only the relocation of the voice bearer but not the relocation of one or more PS bearers succeeds, then the SGSN proceeds step13 after receiving SRVCC PS to CS Response from the MSC Server in step 12 and both UE and SGSN continue the procedure described in clause 6.3.2.1A.

7 Charging

See TS 23.292 [13] clause 8 on charging for guidance on the handling of charging for SRVCC.

8 Handover Failure

8.1 Failure in EUTRAN/UTRAN (HSPA) and 3GPP UTRAN/GERAN SR-VCC

8.1.1 Failure before MSC Server initiates Session Transfer

If a failure is encountered before the MSC Server initiates Session Transfer, then the standardised handover failure procedures apply according to TS 23.401 [2]. No further action is required by the UE.

8.1.1a Failure after MSC Server initiates Session Transfer

8.1.1a.1 Failure before responding to PS to CS HO request

If the MSC Server receives a negative response from IMS during the Session Transfer procedure (e.g., due to invalid STN-SR, or temporary failure, etc) and the MSC Server has not yet responded back to MME/SGSN with a positive PS to CS Response message due to successful target CS radio resource reservation, then MSC Server shall reject this PS To CS Request with a Reject cause pointing to either permanent or temporary "Session Transfer leg establishment error" and MSC Server shall release the CS radio resource at the target RAT.

NOTE 1: An example of permanent error can be an invalid STN-SR (i.e., IMS returns with "404 user unknown").

When MME/SGSN receives the PS to CS Response with a reject cause related to "permanent Session Transfer leg establishment error", MME/SGSN may take that indication into account to prevent further SRVCC handover attempts.

NOTE 2: It is an implementation option on when the MME/SGSN may retry SRVCC after receiving a "permanent Session Transfer leg establishment error".

The following figure 8.1.1a-1 shows the overall procedure when the MSC Server aware of the Session Transfer failure prior to responding to PS to CS HO request.

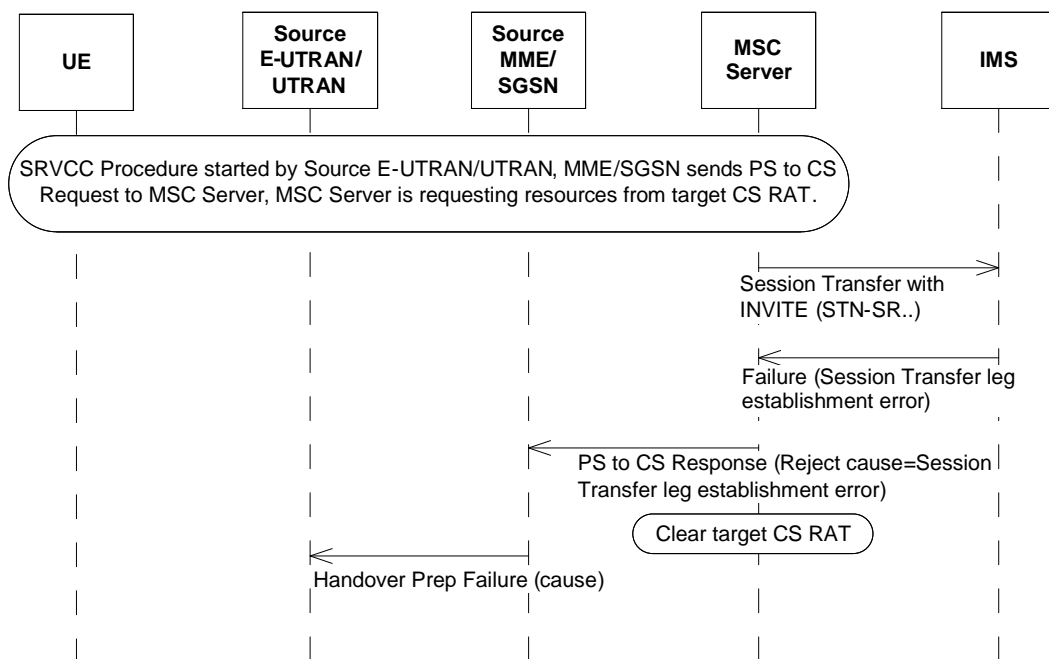

Figure 8.1.1a-1: SRVCC Handover Rejection due to Session Transfer leg establishment error before responding to PS to CS HO request

8.1.1a.2 Failure after responding to PS to CS HO request

If the MSC Server receives a negative response from IMS during the initiates Session Transfer procedure (e.g. due to invalid STN-SR, or temporary failure, etc) and the MSC Server has already responded back to MME/SGSN with a positive PS to CS Response message due to successful target CS radio resource reservation and has not yet sent PS to CS Complete Notification, then MSC Server shall indicate to MME/SGSN with an error cause pointing to either permanent or temporary "Session Transfer leg establishment error" in PS to CS complete notification message. MME/SGSN shall perform the bearer release procedure as according to the normal SRVCC procedure as defined in clauses 6.2 and 6.3.

NOTE: MSC Server may wait for the status of Session Transfer procedure before sending the CS Complete Notification to MME/SGSN.

When MME/SGSN receives this PS to CS Complete notification message with an error cause pointing to "permanent Session Transfer leg establishment error", MME/SGSN may take that indication into account to prevent further SRVCC handover attempts.

The following figure 8.1.1a-2 shows the overall procedure when the MSC Server aware of the Session Transfer failure after the PS to CS HO request has been responded to MME/SGSN.

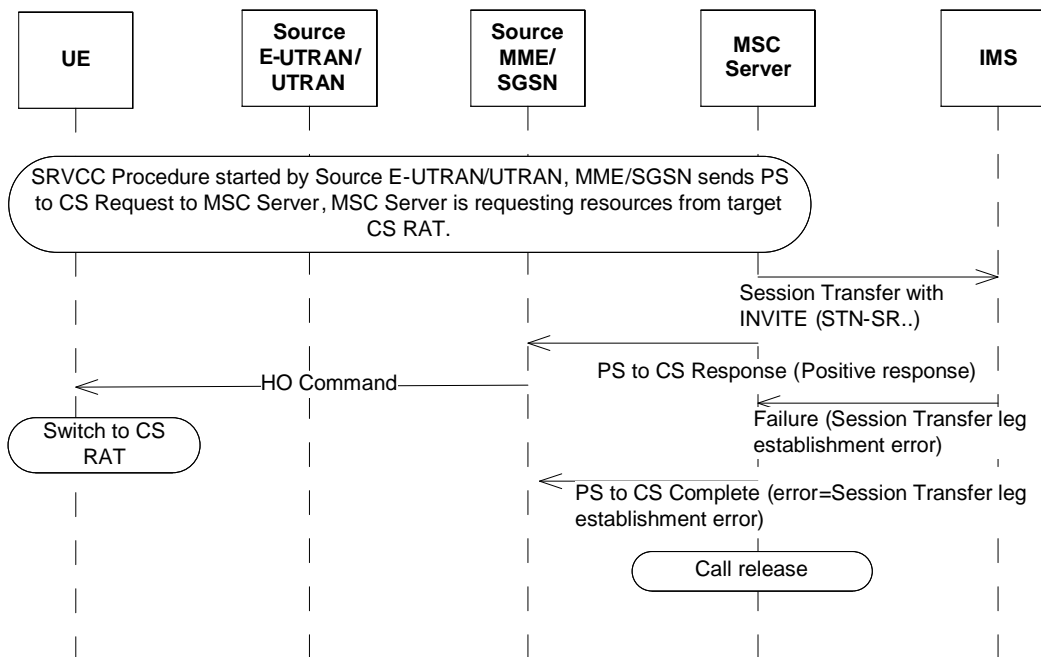

Figure 8.1.1a-1: SRVCC Handover Rejection due to Session Transfer leg establishment error after responding to PS to CS HO request

8.1.2 Failure after UE receives HO command

If the UE encounters a failure at the radio level after it receives the handover command and does not successfully transition to 3GPP UTRAN/GERAN RAT, the UE attempts to return to E-UTRAN/UTRAN by sending a re-INVITE to the SCC AS. The core network (MME, MSC Server) shall take no SR-VCC specific action in the event of not receiving the Handover Complete message from the UE.

8.1.3 Handover Cancellation

If the source E-UTRAN/UTRAN decides to terminate the handover procedure before its completion, the MME/SGSN shall return to its state before the handover procedure was triggered. The MME/SGSN attempts to trigger, at the MSC Server enhanced for SRVCC, handover cancellation procedures according to TS 23.009 [18].

The MME/SGSN shall also send a session reestablishment trigger notification to UE to start the recovery procedure if it receives notification from the MSC Server that the Session Transfer procedure is in progress.

The source E-UTRAN/UTRAN shall not attempt any new SRVCC procedures until the cancellation has successfully been completed and source E-UTRAN/UTRAN have received an acknowledgment of the previous HO cancellation. If MSC has already triggered session transfer, then the UE needs to be provided with a Session Reestablishment trigger before a new cancellation attempt.

Figure 8.1.3-1 shows the overall procedure for SRVCC handover cancellation.

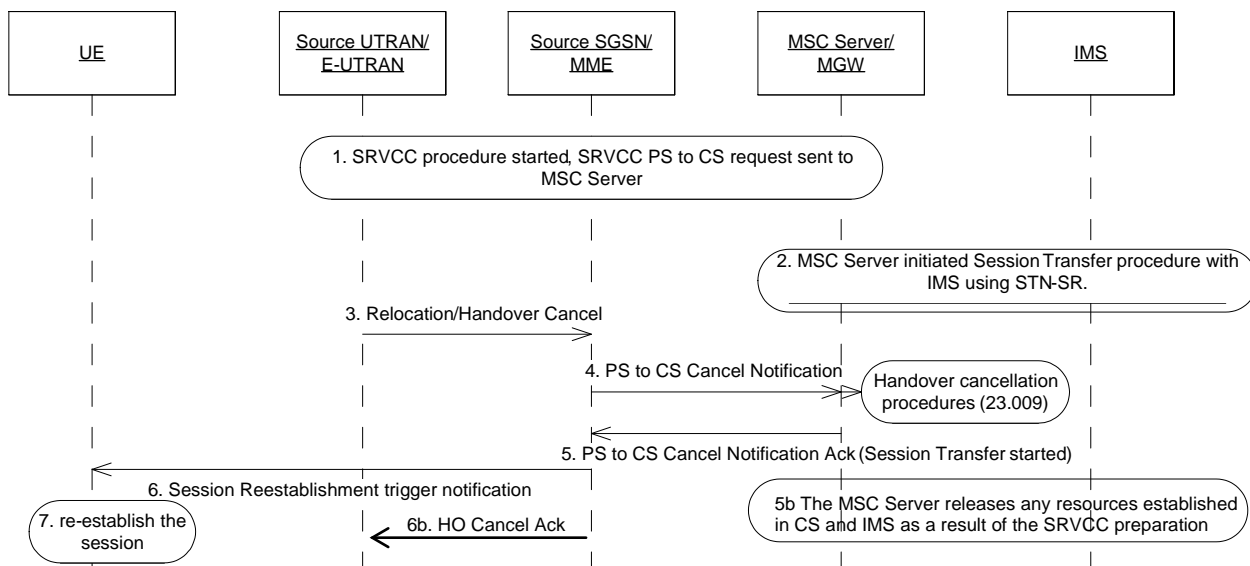

Figure 8.1.3-1: SRVCC Handover Cancellation Procedure

1. Network has started the SRVCC procedure. SGSN/MME has sent the SRVCC PS to CS request to MSC Server.
2. MSC Server is performing the CS HO procedure with target network, and has also started the Session Transfer procedure with IMS with STN-SR, see TS 23.237 [14].
3. Source UTRAN/E-UTRAN decides to cancel the SRVCC HO Procedure by sending a Cancel message to SGSN/MME.
4. Source SGSN/MME indicates SRVCC PS to CS Cancel Notification to MSC Server to start the HO cancellation procedure as according to TS 23.009 [18].
5. MSC Server acks the PS to CS Cancel Notification with an indication that Session Transfer procedure is in progress.
- 5b. The MSC Server releases any resources established in CS and IMS as a result of the SRVCC preparation.
6. Due to the Session Transfer procedure in progress indication, the source SGSN/MME sends a Session Reestablishment trigger notification to UE to start the session re-establishment procedure
- 6b. The source SGSN/MME confirms the Cancel message provided in step 3.
7. UE starts the re-establishment procedure, by attempting to return to E-UTRAN/UTRAN by sending a re-INVITE towards IMS for the related session. If the session is no longer active, then this session transfer request shall be rejected by the IMS.

9 Security

9.1 Network Domain Security with 3GPP2 1xCS IWS

Network domain security with 3GPP2 1xCS IWS shall be provided by NDS/IP according to TS 33.210 [21] with integrity protection and confidentiality. This shall be applied whenever signalling messages (e.g. containing security context) are transferred on the S102 reference point.

NOTE 1: In case control plane interfaces are trusted (e.g. physically protected), there is no need to use protection according to TS 33.210 [21].

9.2 Network Domain Security with 3GPP UTRAN/GERAN MSC Server

Network domain security with 3GPP UTRAN/GERAN MSC Server shall be provided by NDS/IP according to TS 33.210 [21] with integrity protection and confidentiality. This shall be applied whenever signalling messages (e.g. containing security context) are transferred on the Sv reference point.

NOTE 2: In case control plane interfaces are trusted (e.g. physically protected), there is no need to use protection according to TS 33.210 [21].

Annex A (informative): Determination of Neighbour Cell List

This annex describes example algorithms for determination of Neighbour Cell List (NCL) for SRVCC operation. In case of SRVCC to GERAN/UTRAN it is also clarified when the E-UTRAN includes a SRVCC indication in the Handover Required message.

A.1 SRVCC from E-UTRAN to 3GPP2 1xCS

E-UTRAN may determine the NCL as follows:

- If the "SRVCC operation possible" indication is set to "true" (i.e. both EPC and UE are SRVCC capable), then:
 - if there is an established QCI=1 bearer for this UE, then 1x cells may be included as candidate target cells in the NCL;
 - if there is no established QCI=1 bearer for this UE, then 1x cells are not included in the NCL.
- If the "SRVCC operation possible" indication is set to "false" (i.e. either EPC or UE is not SRVCC capable), then 1x cells are not included in the NCL.

A.2 SRVCC from E-UTRAN to GERAN/UTRAN

E-UTRAN may determine the NCL, as well as the need to signal a SRVCC indication, as follows:

- If the "SRVCC operation possible" indication is set to "true" (i.e. both EPC and UE are SRVCC capable), then VoIP-incapable cells may be included as candidate target cells in the NCL, regardless of the presence of an established QCI=1 bearer for this UE. Moreover:
 - if there is an established QCI=1 bearer for this UE and the selected target cell is VoIP-capable, then E-UTRAN does not include a SRVCC indication in the Handover Required message;
 - if there is an established QCI=1 bearer for this UE and the selected target cell is VoIP-incapable, then E-UTRAN includes a SRVCC indication in the Handover Required message;
 - if there is no established QCI=1 bearer for this UE, then E-UTRAN does not include a SRVCC indication in the Handover Required message;
- If the "SRVCC operation possible" indication is set to "false" (i.e. either EPC or UE is not SRVCC capable), then E-UTRAN does not include a SRVCC indication in the Handover Required message. Moreover:
 - if there is an established QCI=1 bearer for this UE, then VoIP-incapable cell are not be included in the NCL;
 - if there is no established QCI=1 bearer for this UE, then VoIP-incapable cells may be included in the NCL.

A.3 SRVCC from UTRAN (HSPA) to GERAN/UTRAN

Similar logic may be used as in clause A.2 by replacing E-UTRAN with UTRAN.

Annex B (informative): Change history

Change history								
Date	TSG #	TSG Doc.	CR	Rev	Cat	Subject/Comment	Old	New
2011-03	SP-51	SP-110066	0166	-	F	Correction to the UTRAN transparent container	9.6.0	9.7.0
2011-03	SP-51	SP-110066	0167	1	F	Continuation of SRVCC in case PS HO fails	9.6.0	9.7.0
2011-03	SP-51	SP-110066	0168	1	F	Correction to the Handover Cancellation	9.6.0	9.7.0
2011-03	SP-51	SP-110066	0170	1	F	Clarification of SRVCC procedure	9.6.0	9.7.0
2011-03	SP-51	SP-110066	0171	1	F	Clarification of parameter download	9.6.0	9.7.0
2011-03	SP-51	SP-110063	0172	1	F	Correcting misleading note in TS 23.216	9.6.0	9.7.0
2011-03	SP-51	SP-110075	0169	-	F	Correction of Two Figures	9.7.0	10.0.0
2011-06	SP-52	SP-110325	0201	1	A	Correction on source SAI in UTRAN to GERAN SRVCC handover	10.0.0	10.1.0
2011-06	SP-52	SP-110325	0202	2	A	Fix SRVCC related data transfer between MMEs/SGSNs	10.0.0	10.1.0
2011-06	SP-52	SP-110337	0210	3	F	Clarification on the MSC selection mechanism in the MME/SGSN	10.0.0	10.1.0
2011-06	SP-52	SP-110323	0214	1	A	QCI=1 usage in SRVCC	10.0.0	10.1.0
2011-06	SP-52	SP-110337	0216	-	F	Aligning the error procedures for SRVCC with stage 3	10.0.0	10.1.0
2011-12	SP-54	SP-110737	0239	-	F	Correction of roaming procedures for ICS	10.1.0	10.2.0
2012-03	SP-55	SP-120065	0250	1	A	Intra-UMTS SRVCC handover correction	10.2.0	10.3.0
2012-03	SP-55	SP-120075	0246	1	F	SRVCC recovery due to incomplete IMS session continuity procedure	10.2.0	10.3.0
2012-06	SP-56	SP-120237	0293	1	F	Clarification on SRVCC session transfer error handling	10.3.0	10.4.0
2012-12	SP-58	SP-120714	0307	1	F	SRVCC clarification of Failure after responding to PS to CS HO request	10.4.0	10.5.0
2013-06	SP-60	SP-130214	0313	1	F	SRVCC Handover Cancellation corrections	10.5.0	10.6.0