

3GPP TR 22.944 V11.0.0 (2012-09)

Technical Report

3rd Generation Partnership Project; Technical Specification Group Services and System Aspects; Report on service requirements for UE functionality split (Release 11)



The present document has been developed within the 3rd Generation Partnership Project (3GPPTM) and may be further elaborated for the purposes of 3GPP.

The present document has not been subject to any approval process by the 3GPP Organizational Partners and shall not be implemented. This Specification is provided for future development work within 3GPP only. The Organizational Partners accept no liability for any use of this Specification. Specifications and reports for implementation of the 3GPPTM system should be obtained via the 3GPP Organizational Partners' Publications Offices.

Keywords

LTE, LTE, UMTS, Service, Terminal

3GPP

Postal address

3GPP support office address

650 Route des Lucioles - Sophia Antipolis
Valbonne - FRANCE
Tel.: +33 4 92 94 42 00 Fax: +33 4 93 65 47 16

Internet

<http://www.3gpp.org>

Copyright Notification

No part may be reproduced except as authorized by written permission.
The copyright and the foregoing restriction extend to reproduction in all media.

© 2012, 3GPP Organizational Partners (ARIB, ATIS, CCSA, ETSI, TTA, TTC).
All rights reserved.

UMTS™ is a Trade Mark of ETSI registered for the benefit of its members
3GPP™ is a Trade Mark of ETSI registered for the benefit of its Members and of the 3GPP Organizational Partners
LTE™ is a Trade Mark of ETSI currently being registered for the benefit of its Members and of the 3GPP Organizational Partners
GSM® and the GSM logo are registered and owned by the GSM Association

UMTS™ is a Trade Mark of ETSI registered for the benefit of its members
3GPP™ is a Trade Mark of ETSI registered for the benefit of its Members and of the 3GPP Organizational Partners
LTE™ is a Trade Mark of ETSI currently being registered for the benefit of its Members and of the 3GPP Organizational Partners
GSM® and the GSM logo are registered and owned by the GSM Association

Contents

Foreword	4
Introduction	4
1 Scope	5
2 References	5
3 Definitions, symbols and abbreviations	5
3.1 Definitions	5
3.2 Abbreviations	5
4 General Aspects	6
4.1 Overview of User Equipment	6
4.2 Background to Requirements	7
4.3 Assumptions	8
5 Requirements	8
5.1 General	8
5.2 Security	9
5.3 Functionality split	9
5.3.1 MT Functions	9
5.3.2 TE Functions	9
5.4 TE-MT Reference Point	10
Annex A: Example Scenarios	10
Annex B: Scenarios for possible functionality split for the Circuit domain	13
Annex C: Change history	21

Foreword

This Technical Report has been produced by the 3rd Generation Partnership Project (3GPP).

The contents of the present document are subject to continuing work within the TSG and may change following formal TSG approval. Should the TSG modify the contents of the present document, it will be re-released by the TSG with an identifying change of release date and an increase in version number as follows:

Version x.y.z

where:

- x the first digit:
 - 1 presented to TSG for information;
 - 2 presented to TSG for approval;
 - 3 or greater indicates TSG approved document under change control.
- y the second digit is incremented for all changes of substance, i.e. technical enhancements, corrections, updates, etc.
- z the third digit is incremented when editorial only changes have been incorporated in the document.

Introduction

The future environment will be characterised by features such as multimedia services and the convergence of 3GPP systems and the Internet. In this environment the total User Equipment used to access 3GPP services may be implemented over a number of physical devices. For example the User Equipment may include a PC or PDA with appropriate client software as well as a separate module containing radio protocols and other elements. These cases are referred to under the term “UE Functionality Split” or just “UE Split”.

This report identifies scenarios and requirements for UE Functionality Split.

1 Scope

This report identifies scenarios and requirements for UEs with functionality split over multiple devices. Scenarios that are required to be supported in the standard are defined in detail. The requirements in this report should enable interoperability between user equipment components from different vendors. This report is not intended to identify all possible or permitted functionality splits. Certain splits of functionality may be prohibited for security or other reasons. This report does not identify all prohibited scenarios.

2 References

The following documents contain provisions which, through reference in this text, constitute provisions of the present document.

- References are either specific (identified by date of publication, edition number, version number, etc.) or non-specific.
- For a specific reference, subsequent revisions do not apply.
- For a non-specific reference, the latest version applies. In the case of a reference to a 3GPP document (including a GSM document), a non-specific reference implicitly refers to the latest version of that document *in the same Release as the present document*.

- [1] 3GPP TS 21.905: "Vocabulary for 3GPP Specifications".
- [2] 3GPP TS 22.060: "General Packet Radio Service (GPRS); Service Description; Stage 1".
- [3] 3GPP TS 22.228: "Service Requirements for the IP Multimedia; Core Network Subsystem; Stage 1".
- [4] 3GPP TS 23.101: "General UMTS Architecture".
- [5] 3GPP TS 24.002: "GSM-UMTS Public Land Mobile Network (PLMN) access reference configuration".

3 Definitions, symbols and abbreviations

3.1 Definitions

User Equipment Combination: All the user equipment that is connected and used together in a particular scenario. For example a user equipment combination may consist of an MT and all the TEs that are connected to that MT.

User Equipment Component: Any one of a number of separate components of user equipment. User equipment components include MTs and TEs.

3.2 Abbreviations

For the purposes of the present document, the following abbreviations apply:

CC	Call Control
CCC	Call Control Client
CS	Circuit Switched
DT	Data Termination
IMEI	International Mobile Station Equipment Identities
IMS	IP Multimedia Core Network Subsystem
IMSI	International Mobile Subscriber Identifier
IPAF	IP Adaptation Function

IMC	IMS Media Coding
IPDT	IP Data Termination
ISIM	IMS SIM
LAN	Local Area Network
MAC	Medium Access Control
MM	Mobility Management
MT	Mobile Terminal
PC	Personal Computer
PCM	Pulse Code Modulation
PDP	Packet Data Protocol
PDA	Personal Digital Assistant
PS	Packet Switched
RAN	Radio Access Network
RR	Radio Resource
SC	SIP client
SIM	Subscriber Identity Module
SM	Session Management
SMC	Session Management Client
TAF	Terminal Adaptation Function
TE	Terminal Equipment
TMSI	Temporary Mobile Subscriber Identifier
UE	User Equipment
UICC	UMTS Integrated Circuit Card
USIM	UMTS SIM

4 General Aspects

4.1 Overview of User Equipment

3GPP user equipment may take many forms. One case is that all the user equipment is integrated in to a single physical device. This report deals with cases where several different components make up the whole user equipment combination. An example is illustrated below. This illustration is only meant to introduce concepts and not imply any limitations or physical form for user equipment.

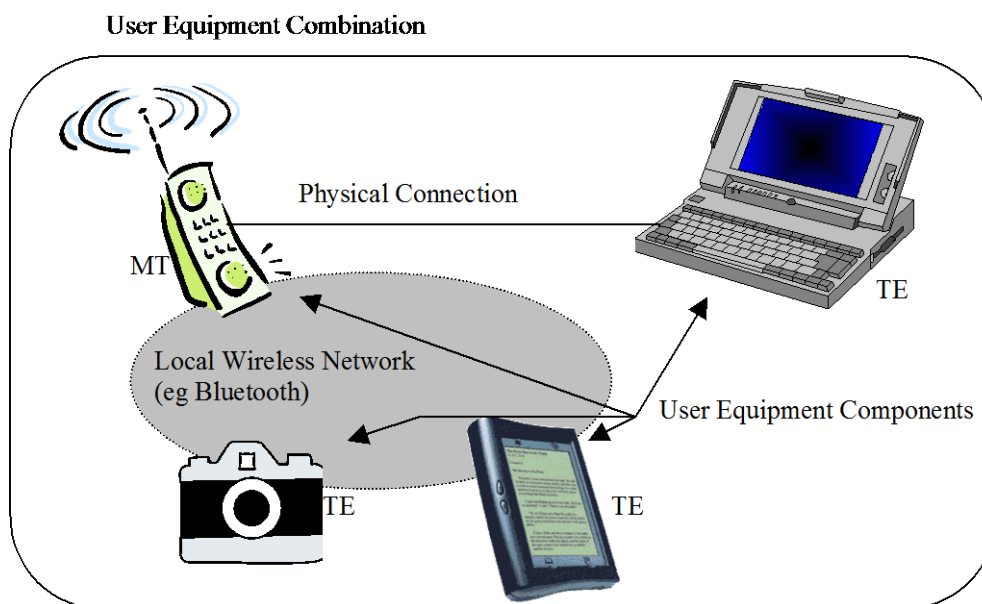

Figure 1: User Equipment Combination

The user equipment combination contains at least one MT and may also contain one or more TEs.

4.2 Background to Requirements

The support of UE-functionality split in 3GPP should aim to exploit technology trends and to promote the convergence of 3GPP technologies with Internet and computing technologies. The objective of this report is to identify a scenario which is seen as being particularly important for the success of the 3GPP system. The scenario should:

- correspond to likely physical scenario for available equipment
- offer attractive commercial opportunities
- be simple enough to allow requirements capture and technical specifications to be completed
- align with other standards (e.g. Bluetooth, PC-Card) and common industry practice (e.g. major operating systems) where appropriate

Allowing some 3GPP related applications to be implemented on TEs separate from the MT offers advantages such as:

- Ability for applications to evolve without changing hardware or firmware. This will improve service velocity.
- Ability of 3GPP applications to integrate with a user's other business, entertainment and communications tools.
- Allowing 3GPP applications to take advantage of the physical characteristics of computer (e.g. large display, memory, processing power)
- Ability to use hardware built into the TE (eg speaker, microphone) for input and output.
- Integration of emerging wireless LAN technologies (e.g. Bluetooth, 802.11b) with 3GPP networks

This will facilitate the development of applications in the TE that use 3GPP services independently of the specific 3GPP defined radio module being used. For example the application developer should not need to write different applications for 3GPP defined radio modules made by different vendors.

The scenario considered is shown in Figure 1. In this case, multiple independent applications that are possibly being used by independent users employ one subscription and its information is stored in one UICC as shown in Fig. 1. The user(s) identity is possibly different from the subscribers' identity.

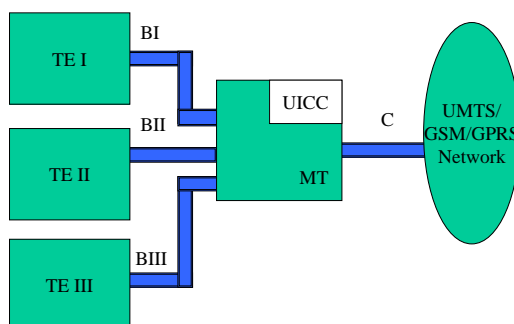

Figure 2: Multiple applications and/or users with one subscriber identity.

Note: The single TE associated with a single MT scenario is a special case of this scenario.

In this case the restriction is that only a single subscription on the UICC may be active. In this release a subscription consists of a SIM/USIM for non-IMS subscribers or a ISIM/USIM pair for IMS subscribers.

Examples of where scenario 1 is useful include:

- A PC or PDA contains a 3GPP defined radio module to allow it to access 3GPP services. The module may be a (semi)permanent part of the PC or PDA (similar to an embedded modem) or a removable module such as a PC card.

4.3 Assumptions

The following assumptions are made:

- a The transport link between the TE and MT functions of the UE is not necessarily secure.
- b A SIM/USIM application resident on a UICC is required to access the 3GPP system . Only a single USIM on a UICC can be active at any time (multiple USIMs can be located on a UICC).
- c Charging is linked to one particular USIM.
- d The secret key and the authentication algorithm cannot be transferred out from the USIM.
- e The UICC must be present during the entire duration of the call. Periodic UICC presence detection is mandatory during a call.
- f Requirements identified in [3] regarding the ISIM must be fulfilled.

Note: In particular the following requirement from [3] is relevant: “For this release of UE-split the USIM and the ISIM shall reside on the same UICC (i.e., the ISIM application shall require the presence of a USIM application on the same UICC). This shall not preclude the possibility in later releases of having an ISIM in a UICC that does not contain a USIM.”

Note: The following maybe later moved into an appropriate stage 2 document if considered necessary. The functionality split required in this case corresponds to generic way computers treat other types of network interface cards. In this configuration the basic 3GPP protocols are implemented in the 3GPP defined radio module (see figure below). The computer contains the following elements:

- driver software to control the 3GPP radio module and interface it to the computer operating system
- software applications using network protocols (such as IP) which are routed to other computers via the card.

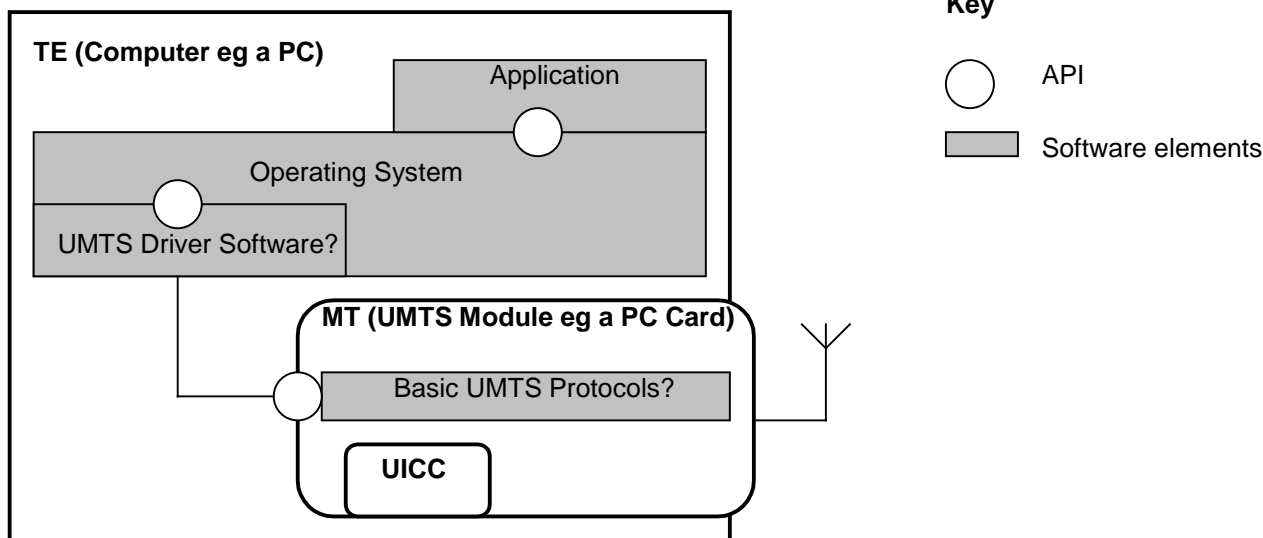

Figure 3: Assumed Topology

5 Requirements

Requirements are identified for only the single active subscription for each TE-MT combination case. Requirements for the other more general cases may be added in later releases.

5.1 General

- 1 The functionality split proposed applies to Circuit Switched (CS) domain.

- 2 The functionality split proposed applies to the Packet Switched (PS) domain.
- 3 The user should be able to control which MTs and TEs are part of their user equipment combination.
- 4 A standardized API for access to capabilities provided by an MT (TE) towards a TE (MT) across Operating Systems must be provided.
- 5 It must be possible to develop applications in the TE that use 3GPP services independently of the specific 3GPP defined radio module being used. For example the application developer should not need to write different applications for 3GPP defined radio modules made by different companies.
- 6 Control over those radio aspects as currently available with AT commands should be provided to the TE by the MT. Access to additional functions is not required.
7. Call control signalling (e.g. IMS SIP signalling) must not be run transparently through the MT by the TE in this Release. [Note: This requirement is FFS currently under review.]

5.2 Security

1. IMEI must be collocated with Mobility Management functions.
2. The USIM/SIM and if relevant the ISIM application must be a part of the MT.
3. The architecture for UE Functionality Split must provide a solution with equivalent or better security than the integrated (non-split) UE architecture. Particular attention should be paid to the origination point of call control signalling to ensure that the TE does not insert false information without detection in the MT or the network.
4. Access to any parts of the network must not be given to unauthorised entities.

5.3 Functionality split

5.3.1 MT Functions

- 1 Radio attachment to the 3GPP network.
- 2 Authenticating subscription(s) (including IMS subscription).
- 3 Communicating with the application(s) resident on the UICC on behalf of the TE.
- 4 Creation/activation/deactivation of additional PDP contexts on demand from a TE.
- 5 Transceiving PS data across the appropriate Radio Access Bearers with the RAN
- 6 Security
- 7 Call control (including call control for IMS) [Note: This requirement is FFS.]
- 8 Mobility Management function. Given this requirement, all relevant security-related identities (IMEI, IMSI, TMSI, etc.) must be located on the MT or UICC.

5.3.2 TE Functions

- 1 Control of hardware in the TE (speaker, microphones, video cameras, displays, etc.)
- 2 Access to services and capabilities provided by the MT. [Note: The services and capabilities provided by the MT which can be accessed by the TE are FFS].
- 3 Call control [Note: This requirement is FFS.]

5.4 TE-MT Reference Point

1. The interface between a TE and an MT uses the 27.007 and 27.005 AT command set. [Editor's Note: Additional functionality may be added in the future.]

Annex A: Example Scenarios

These scenarios were studied and deferred to a later release. They are not enabled by the requirements outlined in this TR.

Scenario 2

In this case, multiple SIM/USIM applications are stored on the MT on a single UICC. Each application (that may be associated with its own unique user) has its own unique SIM/USIM associated with it. The billing is associated with the subscriber's identity stored in the SIM/USIM.

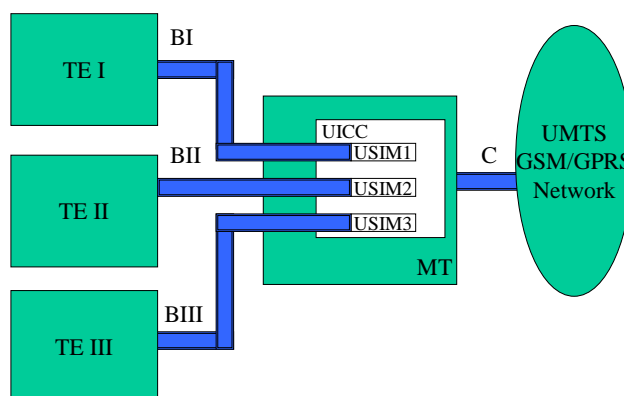

Figure 1 - Multiple users, multiple "borrowed" subscriber identities.

Editors Note: Release 99 allows multiple USIMs stored to be stored on a UICC but they cannot be all active at the same time. In Release 4, the support of logical channels on the UICC enables multiple USIM activation. However, for any registered UICC it is assumed that only one SIM/USIM can be active at any given time.

The scenarios discussed above can be divided into two categories based on the number of simultaneously active subscriptions per user equipment configuration. Scenario 1 and Scenario 2 are examples of cases where there is a single active subscription per UE. This implies that for these scenarios:

- 1) The user equipment combination shall contain only one active SIM/USIM.
- 2) The user equipment combination shall contain only one active MT.
- 3) All MTs and TEs in a particular user equipment combination shall be treated by the 3GPP system as being under the responsibility of the subscription identified by the active SIM/USIM. All charges made by 3GPP shall be directed to the subscriber identified by the SIM/USIM.

Note: It is possible that charges that are not related to the 3GPP subscription may be treated differently for different TEs in the same user equipment combination. For example a user on a TE may access an Internet service which charges them based on a credit-card or a subscription that is not associated with 3GPP.

Note: If a 3GPP subscriber permits a TE to be connected to their user equipment combination they shall be willing to accept any charges as a result of this. This is similar to the situation where you lend your phone to another person to allow them to make a call.

Scenario 3

In this case, every user uses subscription per device and each device (e.g. PC, PDA) have a UICC. The MT does not use an UICC, even if an UICC is physically present. In this case, each TE is independent and billed for separately. The MT in this case is used as transmitter with multiplexing capabilities and the CK and the IK are handled by the TEs

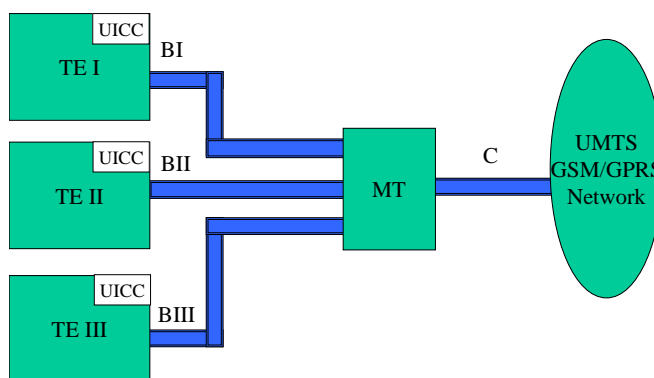

Figure 3 - Multiple users, multiple “owned” subscriber identities.

Due to security concerns this case is not possible, since USIM/SIM applications must be collocated with the Mobility Management on the MT. (It is assumed that the Mobility Management functions are located on the MT).

Scenario 4

In this scenario, every user has a subscription i.e. each user has one UICC that resides in a device (TE + MT) such as the mobile phone (like in case 3). However, the user may be able to transition (henceforth, handoff) into using a different MT (which has a UICC with a SIM/USIM application resident) as shown in the figure below.

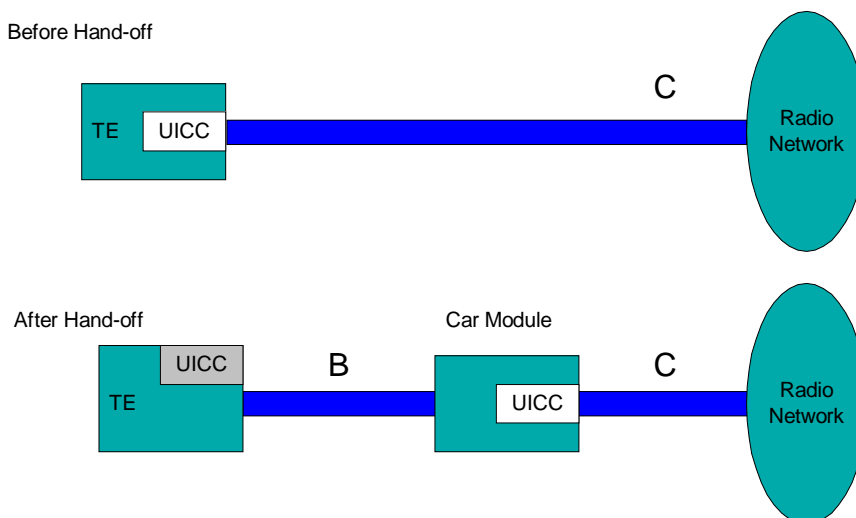

Figure 2: Hand-off to a “borrowed” subscriber identity.

Comments: Hand-off during "IDLE" state may be possible for CS/PS domains using existing services offered by each domain. Significant issues arise if this must be accomplished during "active" state. The assumption is that the handoff is

accomplished using existing supplementary services (call forwarding, explicit call transfer etc). This is under the assumption that after the handoff the functional split will be the same as the TE and MT split case discussed earlier.

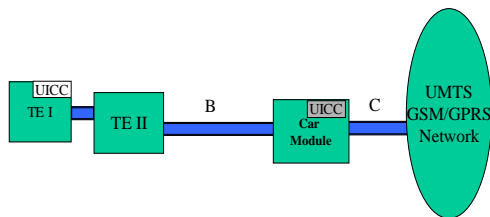

Figure 3: Hand-off, but retain and lend “own” subscriber identity.

In a variation of the scenario under consideration, it may conceivably be possible to use the UICC on the TE while using a borrowed MT. However, this is not possible since the USIM/SIM application and the MM function should be collocated and on the MT.

Annex B: Scenarios for possible functionality split for the Circuit domain

This annex identifies scenarios for possible functionality split for the Circuit domain. It is expected that these scenarios will aid in deciding the functionality splits to be supported. Note that the scenarios enumerated here may not be exhaustive yet and others may be added.

B.1 Telephony

This section deals with circuit-switched voice Telephony.

B.1.1 Functional Elements

The following functional elements are identified as being applicable to the Telephony service:

B.1.1.1 Call Control and Mobility Management (CC&MM)

The Call Control and Mobility Management entity is a C-plane function which supports the signalling for call control and mobility management. The actions of the CC&MM may be initiated directly by the user using a local HMI, or by a Call Control Client on a remote device.

B.1.1.2 Call Control Client (CCC)

The Call Control Client is a client that interfaces to the CC&MM to provide service. The protocol between the CCC and the CC&MM is an intermediate protocol that allows the CCC to signal its call setup and release requirements.

B.1.1.3 Codec

The codec is a U-plane entity responsible for applying the radio-interface voice coding to a PCM or analogue signal.

B.1.1.4 Transducer

The transducer is a U-plane entity responsible for converting between physical sound waves and electrical signals.

B.1.1.5 Radio Resource Layers (RR)

The Radio Resource Layers cover the C-plane and the U-plane. They are responsible for all low-level protocols on the radio interface – including the MAC and physical layers.

B.1.2 Telephony Scenarios

B.1.2.1 Telephony Scenario 1 - Headsets

Telephony scenario 1 corresponds to the use of a headset to access the telephony service. Though a headset is not normally considered to be a TE, from a formal point of view it is an external device connected to the MT and therefore should strictly be included in the discussion. As the question of support for wireless headsets has frequently been mentioned in conjunction with UE-split it is felt necessary to include this scenario for completeness. The model presented is applicable to both wired and wireless headsets.

In Telephony Scenario 1 the TE only contains the transducer. All other functions are included in the MT.

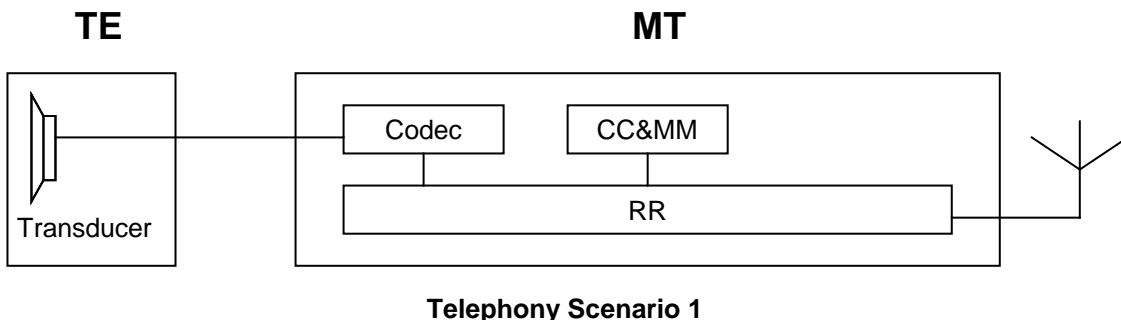

B.1.2.2 Telephony Scenario 2 – Telephony Control Application in TE

This scenario corresponds to the use of a TE (a PC or a PDA) which contains a function to control telephony calls on behalf of the user. This might be a telephone dialler application linked to a contacts database. APIs like “TAPI” are typically used to provide this interface to applications. On the R-interface the AT-command set provides some of the required functionality. In this scenario the user’s voice is still handled only in the MT.

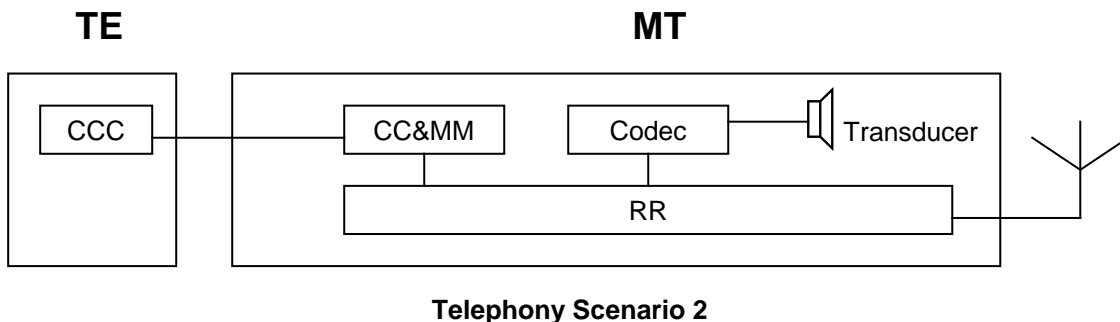

B.1.2.3 Telephony Scenario 3 – Telephony Supported in TE

In this scenario the HMI for the Telephony teleservice is supported in the TE. This may correspond to a user who uses their PC or PDA to initiate calls (the above scenario), but also wants to multiplex the audio component of their calls on to their PCs sound-channel so they can also use the PC’s MP3 or CD player via the same transducer.

The U-plane interface between the TE and the MT is assumed to be PCM or a similar light-weight encoding.

NOTE: This scenario raises the interesting question of TE-split! In this case it is likely the transducer is not physically integrated with the TE, but is in fact a headset connected to the TE. At this level of modelling it is assumed that the internal structure of the TE (even if it is itself made up of several components) is not important provided this doesn’t change the TE-MT interface.

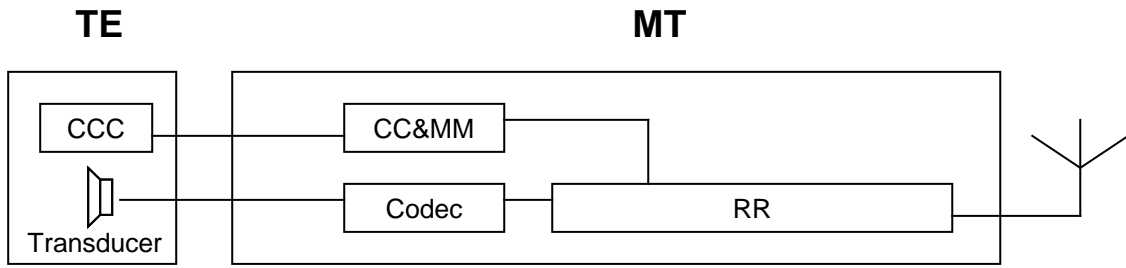

Telephony Scenario 3

B.2 Circuit Bearer Services

This section deals with the circuit-mode data bearer services

B.2.1 Functional Elements

The following functional elements are identified as being applicable to the Circuit Bearer Services:

B.2.1.1 Call Control and Mobility Management (CC&MM)

As for telephony.

B.2.1.2 Call Control Client (CCC)

As for Telephony

B.2.1.3 Terminal Adaptation Function (TAF)

The TAF maps the data format on the R-interface in to the format needed for the bearer.

B.2.1.4 Data Termination (DT)

The data termination is the end-point in the user-equipment for the bearer service. The DT is outside the scope of the 3GPP standard.

B.2.1.5 Radio Resource Layers (RR)

As for Telephony

B.2.2 Circuit Bearer Scenarios

B.2.2.1 Circuit Bearer Scenario 1 – PC or PDA Access

This scenario corresponds to a PC or PDA that uses the circuit bearer service. This scenario is supported by the existing R-interface standards.

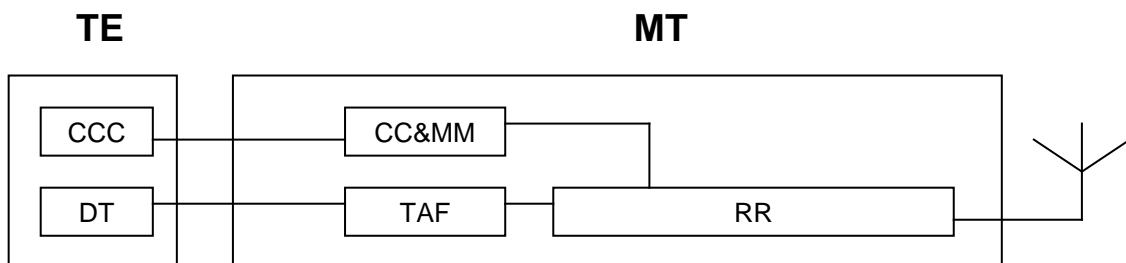

Circuit Bearer Scenario 1

B.4. Packet-Based Data Scenarios

B.4.1. Functional Elements

B.4.1.1 Session Management and Mobility Management (SM &MM)

The Session Management and Mobility Management entity is a C-plane function which supports the signalling for session management and mobility management. Session management includes the establishment, management and release of PDP contexts. The actions of the SM&MM may be initiated directly by the user using a local HMI, or by a Session Management Client on a remote device. This function does not include the SIP client.

B.4.1.2 Session Management Client (SMC)

The Session Management Client is a client that interfaces to the SM&MM to provide service. The protocol between the SMC and the SM&MM is an intermediate protocol that allows the SMC to signal its session setup and release requirements. This is a peer to the SM&MM and does not include SIP

B.4.1.3 SIP Client (SC)

The SIP-client terminates IMS signalling in the user equipment. It is responsible for all the control signalling between the user equipment and the elements of the IMS domain in the network.

B.4.1.4 IP Adaptation Function (IPAF)

The IPAF is a U-plane function that does the high-level mapping of IP data in to the UMTS bearer.

B.4.1.5 IP Data Termination (IPDT)

The IP Data Termination is the end-point in the user-equipment for the IP bearer service provided by the PS-domain. Note that the IPDT is not intended to be part of the IMS. Rather it represents other IP applications that may exist.

B.4.1.6 IMS Media Coding (IMC)

The IMS media coding is similar to the codec in the Telephony service. It converts media formats to those used for IMS. The IMC may support many types of media including speech and video.

B.4.1.7 Multimedia Transducers

The multimedia transducers convert between the physical works and electronic representation of multimedia content. They include microphones, speakers, displays etc.

B.4.1.8 Radio Resource Layers (RR)

As for telephony.

B.4.2 Packet-Based Data Scenarios

B.4.2.1 Packed-Based Data Scenario 1 – PC or PDA Access

This scenario corresponds to a PC or PDA that uses the packet bearer service. This scenario is partially supported by the existing R-interface standards.

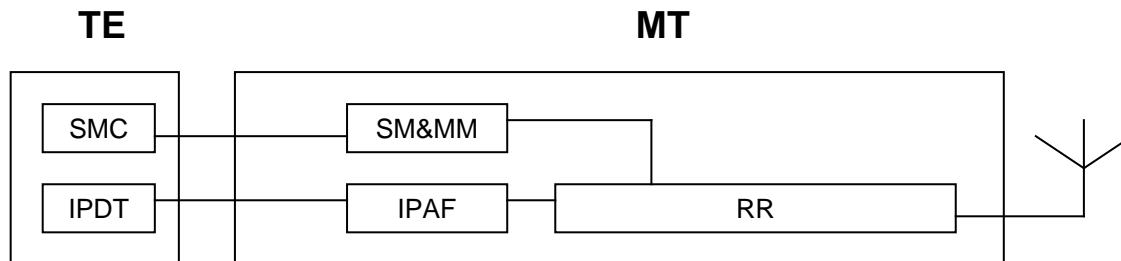

Packet Based Data Scenario

B.4.3 IMS Scenarios

B.4.3.1. IMS Scenario 1 - Headsets

This scenario supports simple headsets by locating the IMS client in the MT and simply using the MT as a transducer. The diagram shows a simple headset plugged in to the MT. The headset may be wired or wireless. It is assumed that the headset only supports audio media. Therefore the transducers are in fact split between the MT and the TE.

Support for PCs and PDAs with limited multimedia capabilities may also conform to this model. This is for further study.

Note that on these diagrams the connections show the flow of content (for C-plane entities “content” is the signalling they use to interact towards the network). Therefore all the internal control relationships are not fully shown. For example the SM&MM obviously interacts with the IPAF and the SIP Client, but this is not shown.

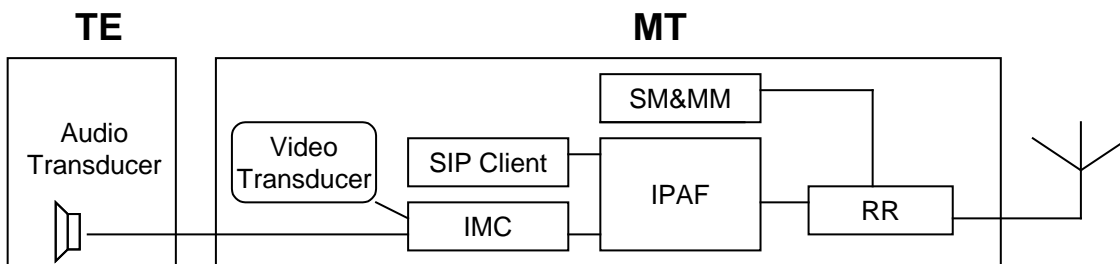

IMS Scenario 1 – Support for Headsets

In operational terms this scenario is very similar to an integrated TE/MT. Therefore it does not introduce many new requirements or problems. One item that should be considered though is the security and access control on the TE->MT interface. It is required that:

- Only headsets the user intends to access his or her MT should be able to connect to the MT. A form of access control is required on this interface.
- It should not be possible to record conversations by monitoring the TE-MT interface. Therefore some form of encryption is required if the TE-MT interface is wireless.

B.4.3.2. IMS Scenario 2 – Multimedia TE

This scenario shows a multimedia SIP client and the media coding located in the TE. In this scenario the functions in the MT are essentially the same as those required in the MT for normal packet-data access (section 4.2.1 of this Annex). This scenario emphasises the requirement for the MT to effectively support QoS management and efficient mapping of data on to the radio interface.

In order to emphasise the similarity to other data access scenarios the TE has been shown to include a generic IP Data Termination (IPDT) which is outside the scope of IMS. The IPDT has been shown as dotted to indicate it is not part of the IMS components. The IPDT may represent another IP application such as a web browser.

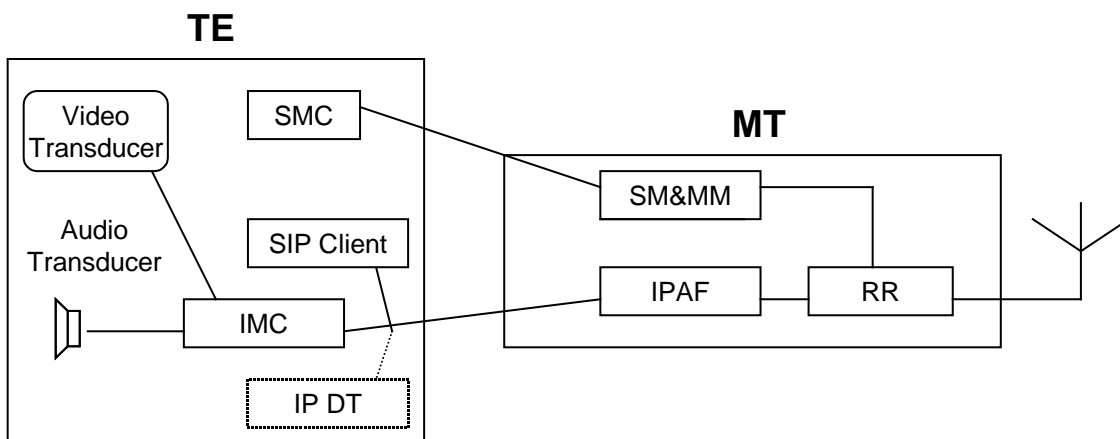

IMS Scenario 2 – Support for Multimedia TEs

In this scenario important UMTS functions are located outside the MT. This means that the system aspects need to be understood. The most important of these are discussed in the following sections.

B.4.3.3. IMS Scenario 3 – Multimedia TE without Codecs

This scenario is intermediate between the other two. It recognises the fact that in the short-term the implementation of media codecs presents special problems for TE hardware. Also the location of codecs outside the MT may complicate the efficient management of the radio interface. Therefore in this model the codecs are located in the MT while the SIP client is contained in the TE.

In this model the requirements and issues are similar to the case above. However some of the complexity in the areas of delay and radio efficiency are avoided. The cost of this simplification is less flexibility in terms of support of new media formats and a system design which is less compatible with other access types.

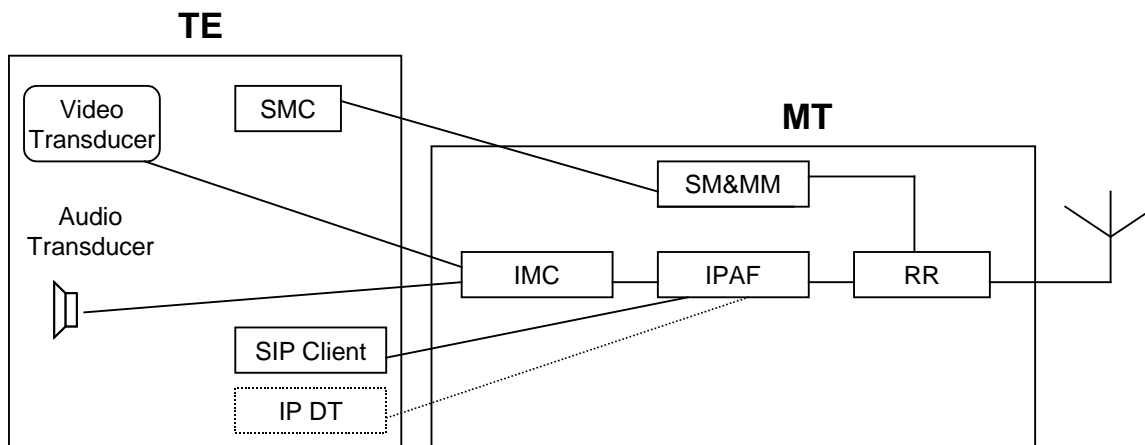

IMS Scenario 3 – Support for Multimedia TEs without codecs

B.4.4. IMS Security and system integrity

The TE – MT link needs to include both confidentiality and access control. These security requirements are similar in any UE-split scenario including the IMS-headset scenario described above.

Locating UMTS functions such as the SIP client outside the MT may be seen as introducing other security risks that arise because of malicious or poorly implemented SIP clients, however these security risks exist for non-split UEs as well. The network must therefore be secure against attacks which may result from maliciously modified SIP clients.

It is possible that the client may attempt to attack nodes in the IMS directly. In order to control this the IMS must include adequate firewalling and IP-based security procedures. These functions should be placed in the network rather than the user equipment so that they cannot be tampered with, and so they can be adapted to meet new threats. Because of the IP-based nature of IMS the security of this network from IP-based attacks needs to be considered whether or not IMS clients are implemented in the TE according to the standard.

B.4.5 End to end delay

End to end delay in IMS scenario 2 is a function of many factors. These includes the hardware on the TE, the codecs in the TE, the mapping of data over the TE-MT interface and the UMTS radio interface. In order to ensure that system-wide delay is managed it is important that:

- The total maximum end-to-end delay limits are defined in 3GPP
- A delay budget is created showing the maximum contribution to the delay at each point in the network
- The technical design of the standard takes in to account delay aspects, and that the interfaces are created in a way where both the theoretical and practical delay consequences are compatible with the delay budget.
- Approved implementations are tested to ensure they meet delay requirements.

5.3 Radio Efficiency

This scenario is not necessarily less radio efficient than other IMS scenarios provided that:

- The MT has sufficient information about the different IP streams it is transporting to map them on to the correct radio access bearer, and
- The IP header compression mechanism on the radio interface supports header stripping and reassembly to support the transparency of the service.

The first point requires developments in the TE's operating system and also on the TE-MT interface.

Annex C: Change history

Change history											
TSG SA#	SA Doc.	SA1 Doc	Spec	CR	Rev	Rel	Cat	Subject/Comment	Old	New	Work Item
	SP-020064	S1-020664	22.944					Approved at SP-15	2.0.0	5.0.0	
SP-16	SP-020253	S1-021134	22.944	001		Rel-5	F	Editorial Corrections to TR 22.944	5.0.0	5.1.0	UESPLIT-TR
SP-16	SP-020253	S1-021132	22.944	002		Rel-5	F	UICC in UE-split	5.0.0	5.1.0	UESPLIT-TR
SP-26	SP-040744	S1-040997	22.944			Rel-6		Updated from Rel-5 to Rel-6	5.1.0	6.0.0	
SP-36			22.944			Rel-7		Updated from Rel-6 to Rel-7	6.0.0	7.0.0	
SP-42	-	-				Rel-8		Updated from Rel-7 to Rel-8	7.0.0	8.0.0	
SP-42	-	-				Rel-8		Updated from Rel-7 to Rel-8	7.0.0	8.0.0	
SP-46	-	-	-	-	-	-	-	Updated to Rel-9 by MCC	8.0.0	9.0.0	
2011-03	-	-	-	-	-	-	-	Update to Rel-10 version (MCC)	9.0.0	10.0.0	
2012-09	-	-	-	-	-	-	-	Updated to Rel-11 by MCC	10.0.0	11.0.0	